

# Rectangular & Radius Corner Worksurface And Accent Shelf Assembly Instructions

Tools required for assembly: #2 Phillips Screwdriver

Screws Prived with this pack:



16 ea. #10x3/4" Screw

The WORKSURFACE / ACCENT SHELF carton includes:

- 1ea. Worktable Top / Accent Shelf (2ea. Corner Shelf)
- 1ea. LH Cantilever Bracket (2ea. Worksurfaces 66" and up)
- 1ea. RH Cantilever Bracket (2ea. Corner Shelf)
- 1ea. Attaching Bracket (Worksurfaces only)
- 1ea. Flat Bracket (Corner Accent Shelf Only)
- 2ea. LH & RH Bracket Support

## INSTRUCTIONS:

### Assembling Worktable

1. Position LH and RH Cantilever into panel slots at desired height locations. **NOTE:** 66"-72" tables place middle cantilever at the same height location. **Corner Worksurfaces only:** Position a Bracket Support in the back corner at same height locations as Cantilevers. (See Diagram 2)
2. Position Worktable onto Cantilevers and secure with (3) #10x3/4" screws per Cantilever. **Corner Worksurfaces Only:** Secure rear corner of worktop to panel with Worksurface Bracket Support with #10x3/4" screws. Position Attaching Bracket at front adjoining Corner Tables and secure with (4) #10x3/4" screws.

### NOTE:

If end of Worktable is adjacent to same depth Return Panel position appropriate LH/RH Bracket Support (see Diagram 4) into panel slots at same height location and secure to Worktable with (1) #10x3/4" screw.

### NOTE:

When mounting a hanging pedestal to a 30" deep worksurface, an end panel leg must be used. Failure to use an end panel leg may result in injury.

### Assembling Accent Shelf

1. Place cantilevers into panel slots at desired height as shown in Diagram 3. Make sure the cantilevers are level, and secured in the panel slots.
2. Place Shelf on the cantilevers as shown in Diagram 4.
3. Secure the shelf to cantilevers using #10x3/4" screws. **Continue on for Corner Shelf only** (when assembling corner shelves, the smaller shelf will **always** go on the right hand panel).
4. Attach flat bracket to right hand of larger shelf securing it with (2) #10x3/4" screws. The bracket should extend out from the front of the shelf.
5. Place 3<sup>rd</sup> cantilever into adjacent panel slots at same height as main shelf.
6. Place shelf on the cantilever and flat bracket.
7. Secure shelf using screws provided.

DIAGRAM 1

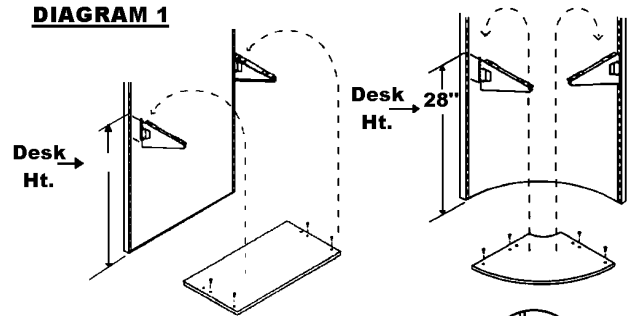

DIAGRAM 2

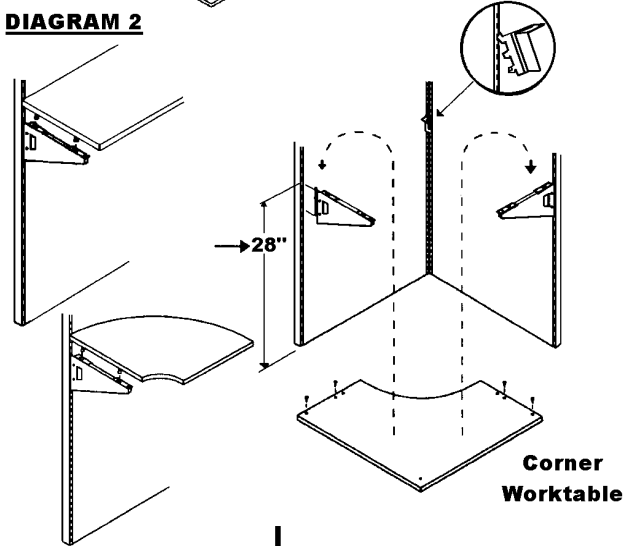

DIAGRAM 3

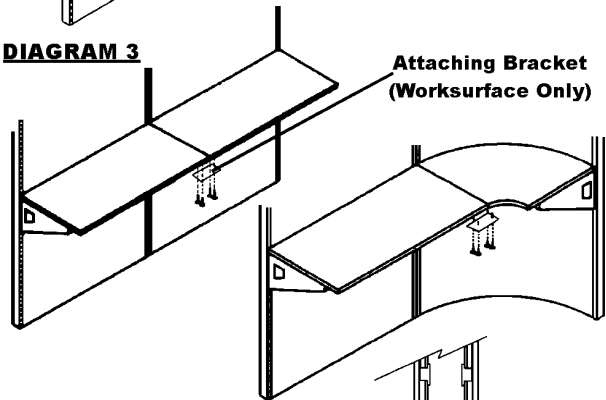
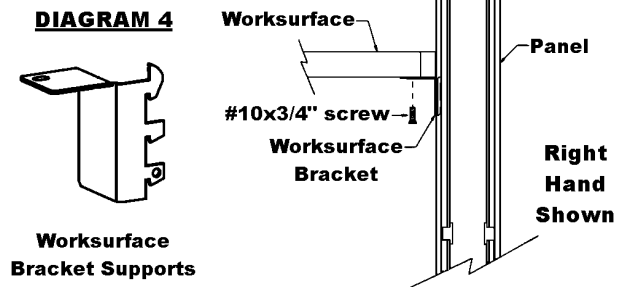

DIAGRAM 4



# Corner Connector and Radius Panel Top Worksurface Tops Assembly Instructions

**Tools required for assembly: #2 Phillips Screwdriver**

**Screws provided in this pack:**

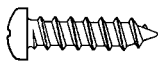

**16ea. #10x3/4" screws**

The CORNER CONNECTOR WORKSURFACE carton includes:

- 1ea. Top
- 2ea. Support Brackets

## **INSTRUCTIONS:**

1. Slide the Mounting Brackets between the Worksurface and Leg Assembly on both Worksurfaces that will support the Corner Connector Worksurface Top (see Diagram 1).
2. Align the supporting Worksurfaces as shown in the diagram.
3. Place the Corner Connector Worksurface Top over the two Mounting Brackets. Screw the Mounting Brackets to the Worksurface Top using the #10x3/4" Screws provided (see Diagram 1).
4. Level Worksurfaces with leg levelers.

## **INSTRUCTIONS WORKTABLE TOP WITH CANTILEVERS**

1. Slide the Mounting Brackets between the Worksurface and Cantilevers on both Worksurfaces that will support the Corner Connector Worksurface Top (see Diagram 2).
2. Place the Corner Connector Worksurface Top over the Mounting Brackets. Screw the Mounting Brackets to the Worksurface Top using the #10x3/4" screws provided (see Diagram 2).

**DIAGRAM 1**

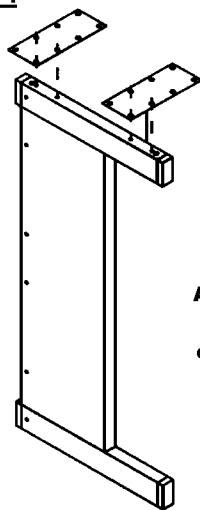

**Attach Universal Bracket to  
Legs as shown securing  
each plate with (2) Tapping  
screws.**

**DIAGRAM 2**

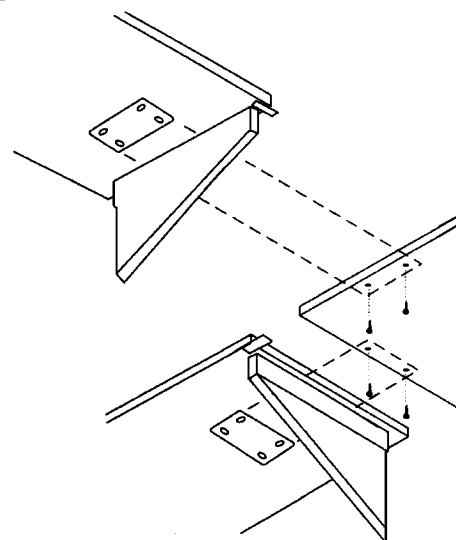
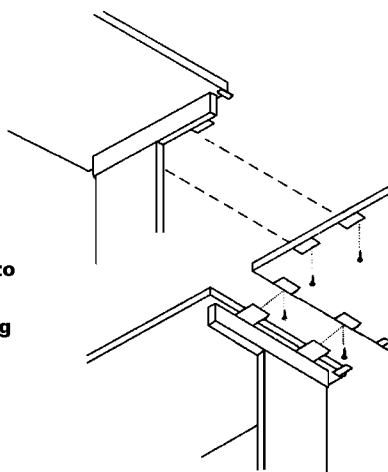

Maxon Furniture Inc.  
21606 86<sup>th</sup> Place South • Kent, WA 98031-1926  
Customer Service 1-800-876-4274

181-30025  
Feb, 2004

SHEET 2 OF 2