

Universal Overhead Cabinet & Hanging Shelf

Assembly Instructions

Hardware provided:

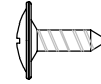

16 ea. #8x1/2" Black Truss Head Screws

Tools required for assembly:

Phillips Head Screwdriver and Pliers (54" and 60" only)

*NOTES:

- Remove parts from carton to verify contents.
- Most applications will not use all of the screws provided.

Corner Shelf Carton includes:

- 1 ea. Corner Shelf
- 2 ea. End Panels (Left and Right)
- 2 ea. Back Strip
- 1 ea. Return Panel Bracket (TL2/Empower only)
- 1 ea. Corner Bracket (Wall Mount only)

Hanging Shelf Carton includes:

- 2 ea. End Panels (Left and Right)
- 1 ea. Shelf
- 1 ea. Back Strip
- 1 ea. Joining Bracket

Hanging Cabinet Carton Includes:

- 2 ea. End Panels (Left and Right)
- 1 ea. Top
- 1 ea. Divider (54" and 60" units only)
- 1 ea. Shelf
- 1 ea. Back Strip
- 1 ea. Door Assembly (2 ea. 54" and 60")
- 1 ea. Joining Bracket

STEP 1: Attach End Panel Assemblies to Panel/Wall

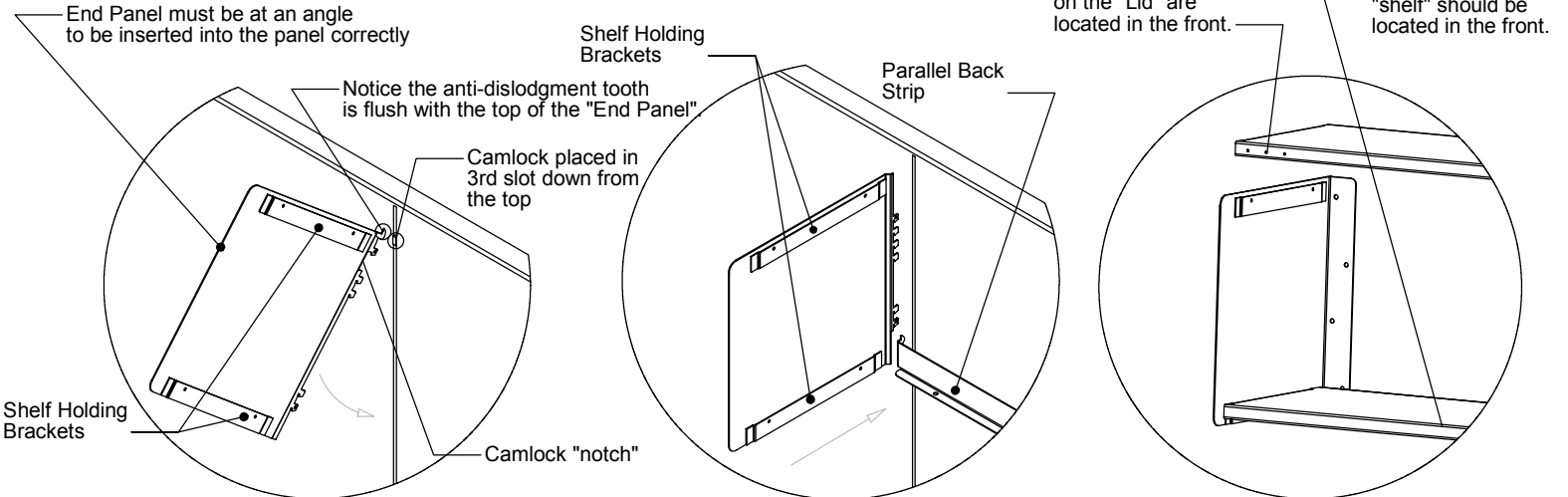

TL2/Empower Shelves and Cabinets

(Standard TL2/Empower Left Hand End Panel shown above)

Parallel Shelves and Cabinets

(Standard Parallel End Panel shown above)

Universal Wall Mount Shelves and Cabinets

Install End Panels at desired location on the panel/wall

- For TL2 and Empower:

1. Verify that the panel camlock has been inserted into the third slot from the top with the lever handle pointing upward (if End Panel will be mounted at the top of the panel).
2. Insert the End Panel into the panel as shown above.
3. Tilt the End Panel down into the panel, then let the End Panel "drop" down into the slots allowing the cantilevered teeth to fully engage.

- Wall Mount option:

1. Assemble the cabinet's Shelf and top Lid (if an overhead cabinet) to the End Panels first (see STEP 2 for Shelf and Lid assembly).
2. Using 2 people, one person holds the cabinet up against the wall while the 2nd person secures it to the wall with the appropriate fasteners (fasteners not included).

- For Parallel:

1. Insert the End Panel into the panel at the desired location, then let the End Panel "drop" down into the slots allowing the cantilevered teeth to fully engage.
2. Insert the cantilevered Back Strip into the panel by tilting the bottom of the Back Strip up towards you, allowing the top tooth to go into the nearest open panel slot at the bottom of the End Panels.

NOTE: For instruction purposes, standard Overhead Cabinets are shown. A variety of Door, End Panel, and Shelf styles are offered, but they still use the same mounting and assembly methods shown here.

STEP 2: Attach Shelf and Lid to End Panels

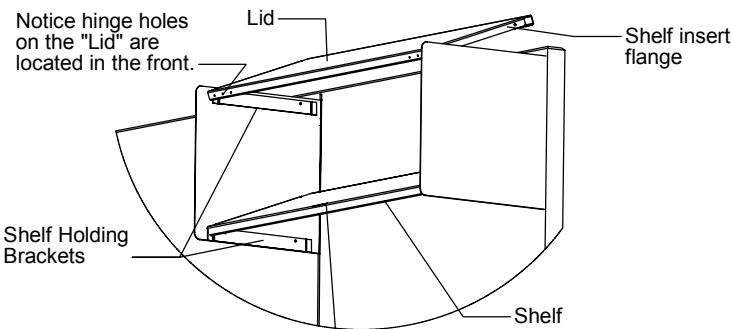

1. FOR CORNER UNITS ONLY: When installing a panel-mounted Corner Shelf, the return panel bracket must be installed prior to the attachment of the Shelf. Where both panels come together, position the return panel bracket into the panel so that the bottom flange of the Corner Shelf will rest upon the top of the bracket. This needs to be positioned correctly to be level. When installing a wall-mounted Corner Shelf, attach the Corner Bracket to the wall so that the Shelf rests upon the top of the Bracket in a level position.
2. With the back of the Shelf tilting upwards (as shown), insert the sides of the Shelf (insert flanges) into the Shelf Holding Brackets and push down into place. Make sure that the Shelf is fully seated and flush with the Holding Brackets (pushing down by hand is usually sufficient, but light taps with a rubber mallet may be necessary).
3. Insert the sides of the Lid the same way the Shelf was attached as described above.



Maxon Furniture Inc.
21606 86th Place South • Kent, WA 98031-1926
a HON INDUSTRIES company
Customer Service 1-800-876-4274

181-40001
July, 2003

SHEET 1 OF 2

Universal Overhead Cabinet & Hanging Shelf Assembly Instructions

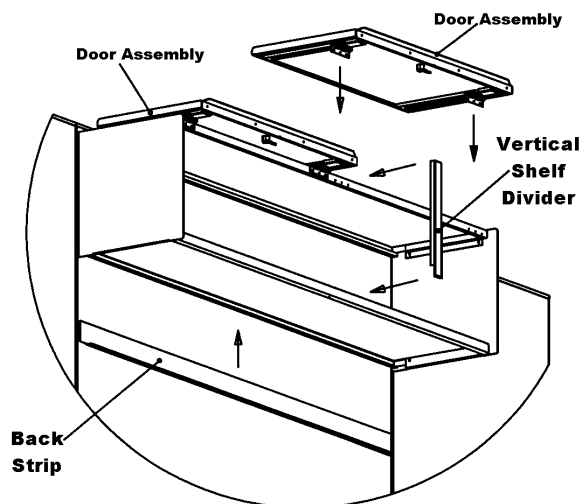
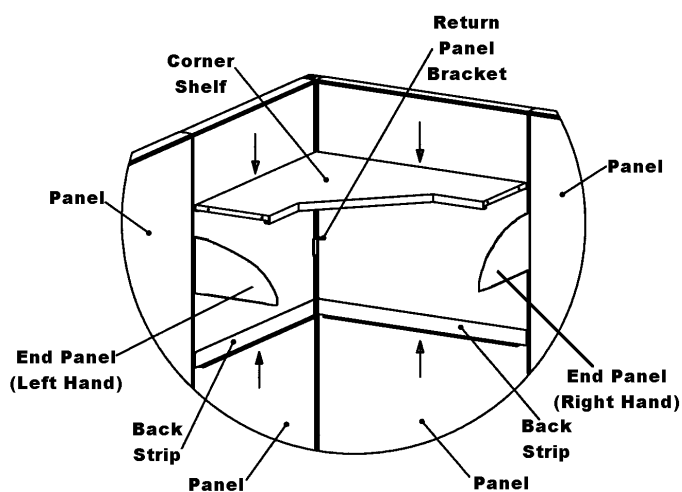

STEP 3: Attach the Back Strip and Divider to the Shelf

NOTE: Parallel's Back Strip should be in place from "STEP 1", but not yet fastened to the Shelf.

1. Place the Back Strip upward between the panel and back edge of the Shelf (TL2 and Empower only; Parallel should be in place).
2. Use (3) screws to attach the Back Strip to the Shelf as shown above.



CAUTION:

Hold down the Shelf while installing the screws. Otherwise, the upward force may lift the Shelf and End Panels off the panel.

3. On the 54" and 60" units, insert bottom tabs of the Divider into the Shelf and twist the tab on the bottom with pliers to secure (see below). Attach the top of the Divider to the Lid with (1) screw.

Divider For 54" and 60" Overhead units only

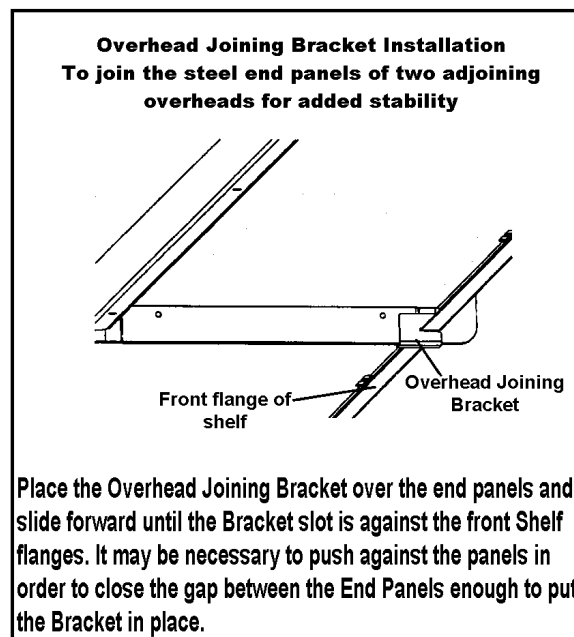
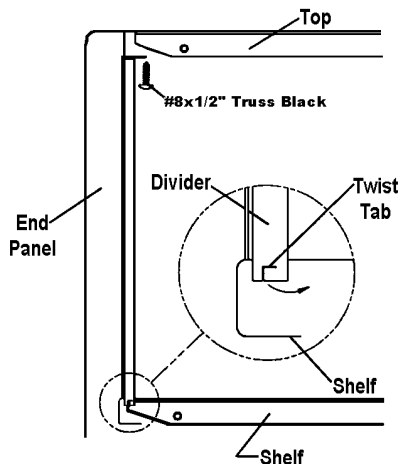

STEP 4: Attach the Door Assembly to the top Lid

1. Place the Door Assembly(s) on top of the Lid.
2. "Loosely" attach the hinges to the Lid's face with (3) screws on each hinge.
3. After centering the doors side to side, tighten all screws.



Maxon Furniture Inc.
21606 86th Place South • Kent, WA 98031-1926
a HON INDUSTRIES company
Customer Service 1-800-876-4274

181-40001
July, 2003

SHEET 2 OF 2