

Adjustable & Articulating Keyboards (ARK4, ARK5, ARK6) Assembly Instructions

Tools required for assembly: #2 Phillips Screwdriver

Screws provided with this pack:



12ea. #8x5/8" Wood Screw
(Laminate Keyboards only)

NOTE: Tray to mechanism fasteners are provided by the keyboard manufacturer.

The KEYBOARD carton includes:

- 1ea. Adjustable Mechanism
- 1ea. Keyboard Surface

INSTRUCTIONS FOR MOUNTING KEYBOARDS TO MAXON PREDRILLED WORKSURFACES:

1. Mount the Keyboard Surface to the Adjustable or Articulating Mechanism as specified below:
Laminate Adjustable: Use 6 of the #8 wood screws to mount the mechanism to the underside of the laminate keyboard (Diagram 1).
ARK4, ARK5, ARK6: Use the screws that came with the keyboard tray to mount the keyboard tray to the mechanism (Diagram 2).
2. Mount the Mechanism to the underside of the worksurface using 6 of the #8 wood screws. Be sure to use the hole pattern shown or the keyboard will not work properly (Diagram 4 and 5, see other side)
ARK4 ONLY: Secure the base frame and then install the mechanism according to the instructions included with the mechanism.
3. Adjust the Keyboard to suit the needs of the user.
Laminate Adjustable: Refer to Diagram 6 (see other side). Grab both sides of the Keyboard Surface, and tilt the Keyboard Surface in the direction of the arrows to release. Adjust the Keyboard Surface to the desired height. Tilt the Keyboard Surface in the reverse direction of the arrows to lock in place.
ARK4, ARK5, ARK6: Follow the adjustment instructions included with the Adjustable Mechanism.

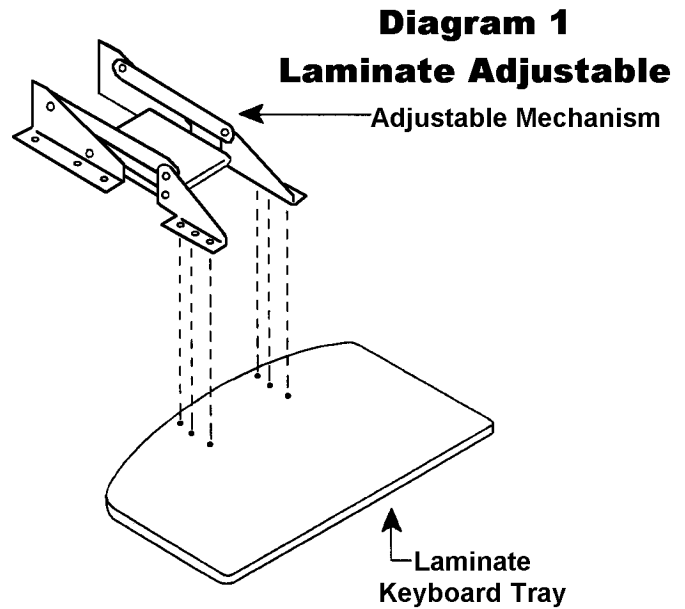
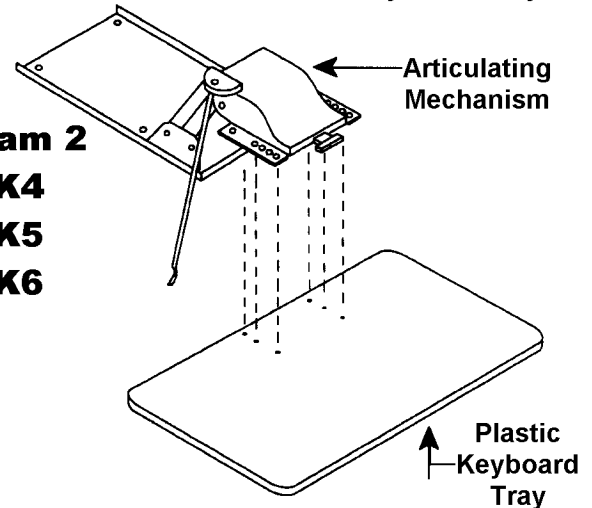

Diagram 2

ARK4
ARK5
ARK6



Adjustable & Articulating Keyboards (ARK4, ARK5, ARK6) Assembly Instructions

INSTRUCTIONS FOR MOUNTING KEYBOARDS TO NON-PREDRILLED WORKSURFACES:

1. Turn the Worksurface upside down.
2. Use the template that comes with the Keyboard Mechanism. Align the template with the front of the worksurface. Tape the template into place. Drill 6 holes through the template, into the worksurface using a 1/16" drill bit (see diagrams 4 and 5)
NOTE: Be careful – don't drill through the top of the worksurface.
3. To mount the tray and mechanism, follow the assembly instructions as shown in Steps 2 and 3 for mounting to Maxon Predrilled Worksurfaces (see other side).

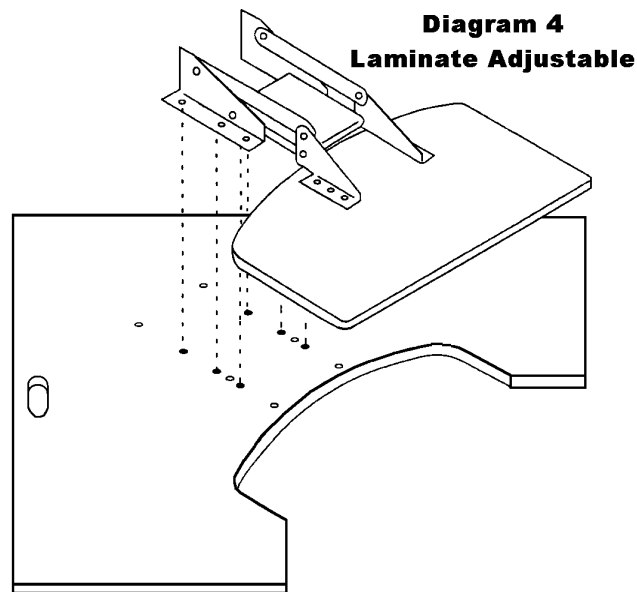

Diagram 5
ARK5, ARK6

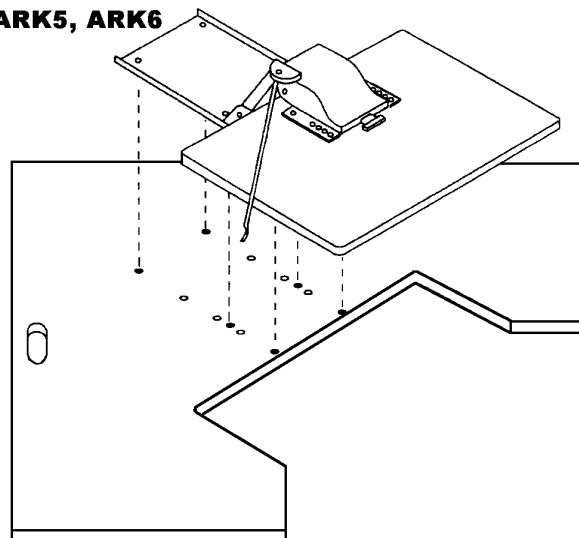

Diagram 6
Laminate Adjustable

