

**KR Training & Conference Room Tables
Rectangle, Trapezoid and Half Moon
Assembly Instructions**

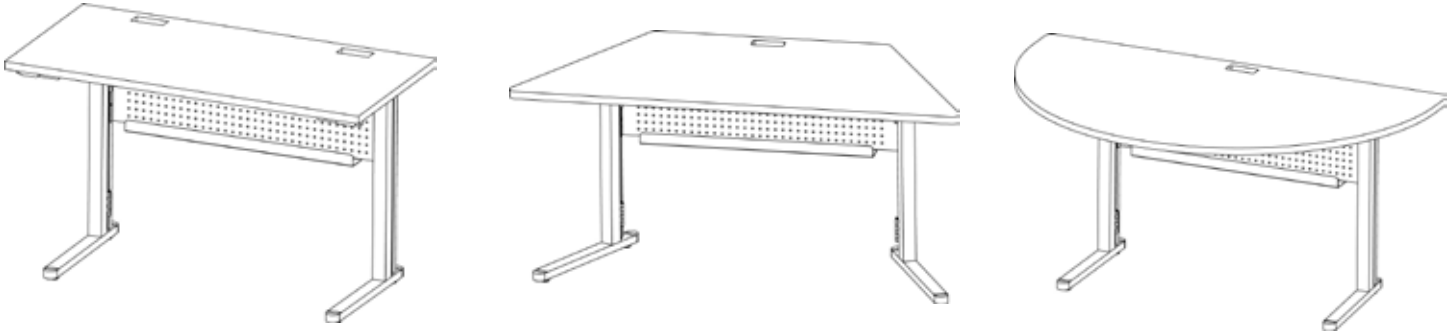

Parts List

Qty.	Part No.	Description
1	022-2754	Frame Assembly for 48”L Rectangle Tables
	022-2755	Frame Assembly for 60”L Rectangle Tables
	022-2756	Frame Assembly for 72”L Rectangle Tables
	022-2758	Frame Assembly for Trapezoid Tables
	022-2757	Frame Assembly for Half Moon Tables
1	022-2750	Left Pedestal Upright for 18”D Rectangle Tables
	022-2752	Left Pedestal Upright for 24”D & 30”D Rectangle Tables and Trapezoid and Half Moon Tables
1	022-2751	Right Pedestal Upright for 18”D Rectangle Tables
	022-2753	Right Pedestal Upright for 24”D & 30”D Rectangle Tables and Trapezoid and Half Moon Tables
1	SA7704	Worksurface Top for KR1848
	SA7705	Worksurface Top for KR1860
	SA7706	Worksurface Top for KR1872
	SA7707	Worksurface Top for KR2448
	SA7708	Worksurface Top for KR2460
	SA7709	Worksurface Top for KR2472
	SA7710	Worksurface Top for KR3048
	SA7711	Worksurface Top for KR3060
	SA7712	Worksurface Top for KR3072
	SA7713	Worksurface Top for KTRP24
	SA7714	Worksurface Top for KTRP30
	SA7715	Worksurface Top for KHAF24
	SA7716	Worksurface Top for KHAF30

Hardware List

Ref.	Qty.	Part No.	Description
AA	2	010-2148	Leg Latches
BB	2	010-2151	Leg Stop Brackets
CC*	1	010-4913	Left Locking Plate
DD*	1	010-4915	Left Latch Plate
EE*	1	010-4914	Right Locking Plate
FF*	1	010-4916	Right Latch Plate
GG	2	010-2971	Ganging Clips
HH	16	030-0402	#10-32 x 5/8” Combo Screws
II*	4	030-0291	#10-32 x 1/2” Phillips Truss Screws
JJ*	4	030-0371	.50” Plastic Washers
KK*	4	030-0461	10-32 Nylock Hex Nuts
LL	4	030-0444	10-32 Black Knobs

* These parts are pre-assembled in the hardware pack

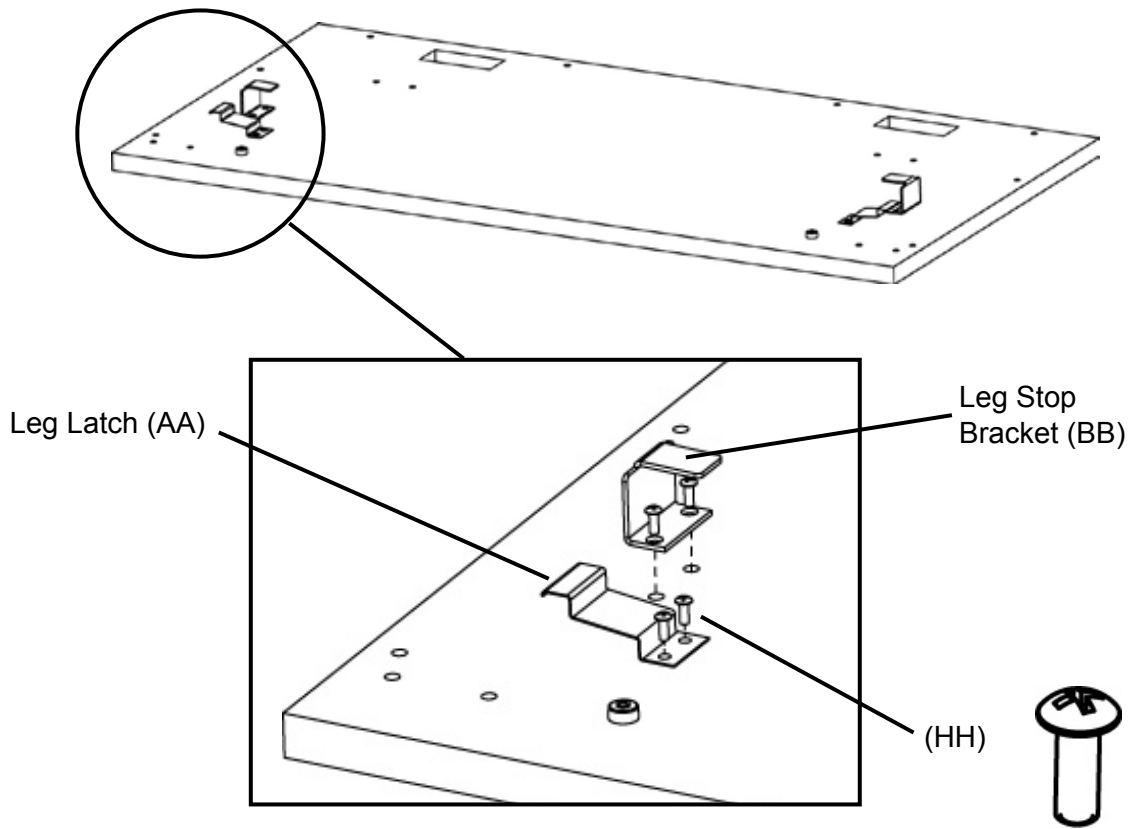

STEP 1

Lay work surface down with holes facing up as shown. **LOOSELY** attach leg latches and stop brackets with screws (HH) as shown.

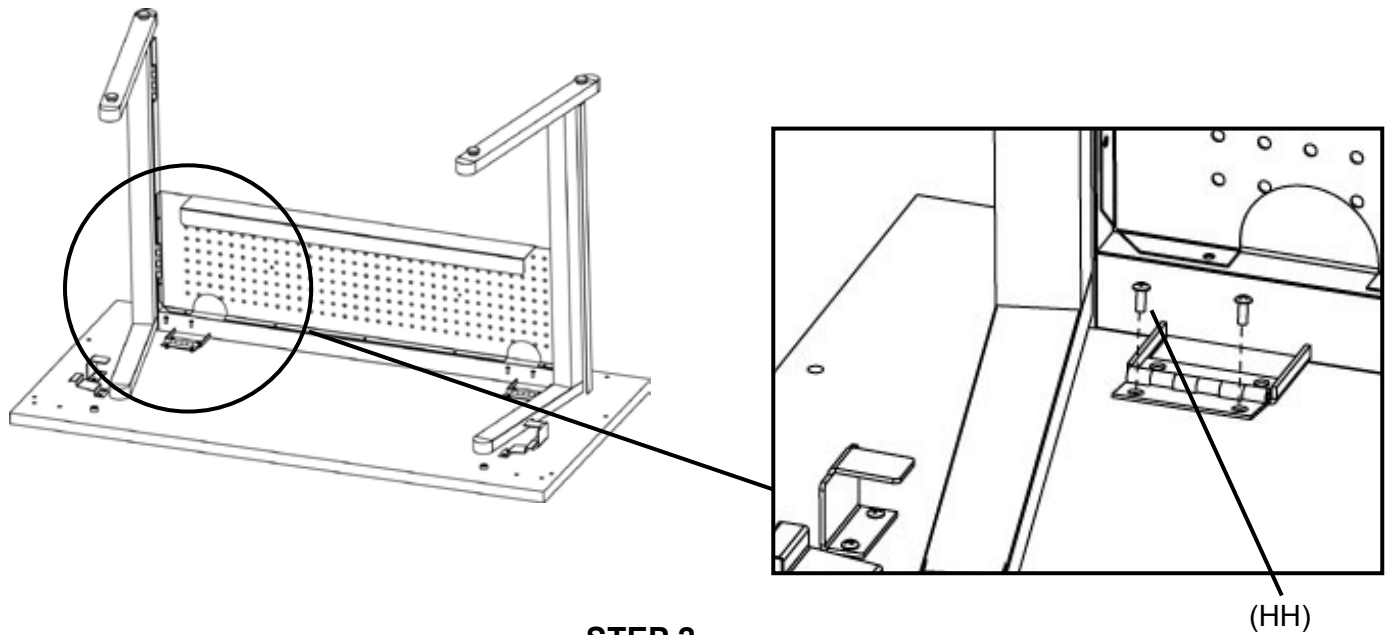

STEP 2

Align frame assembly with legs turned in slightly on work surface as shown. **LOOSELY** attach with screws (HH) as shown.

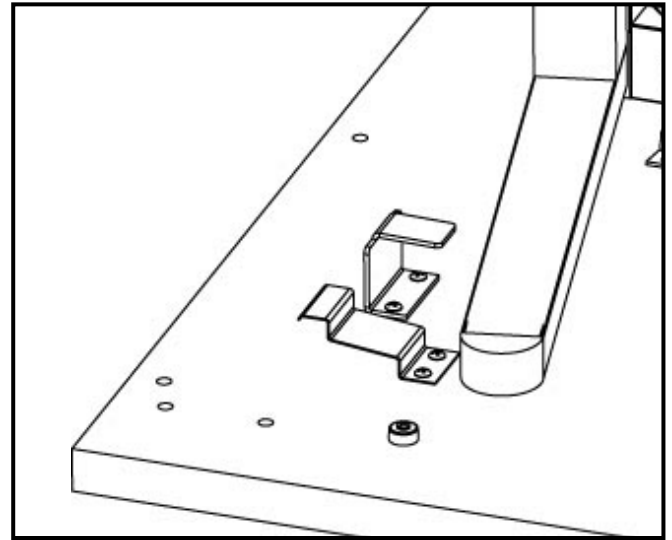
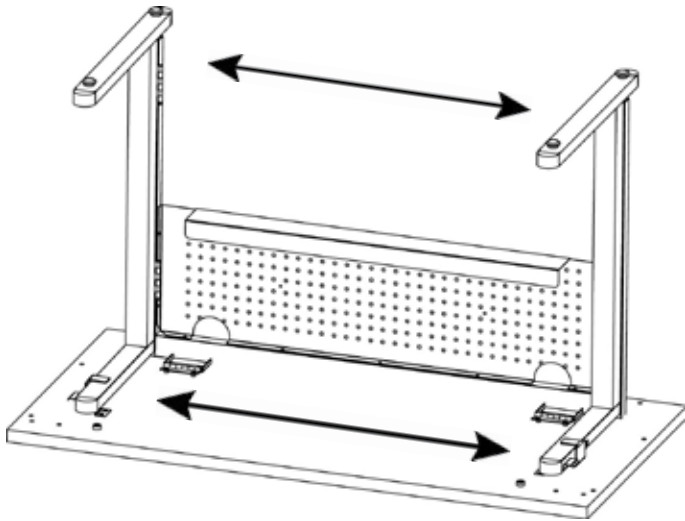

STEP 3

Carefully slide legs into latches as shown. **FULLY TIGHTEN FRAME SCREWS.** Then hold down latches and close leg slightly. **FULLY TIGHTEN ALL BRACKET HARDWARE NOW.**

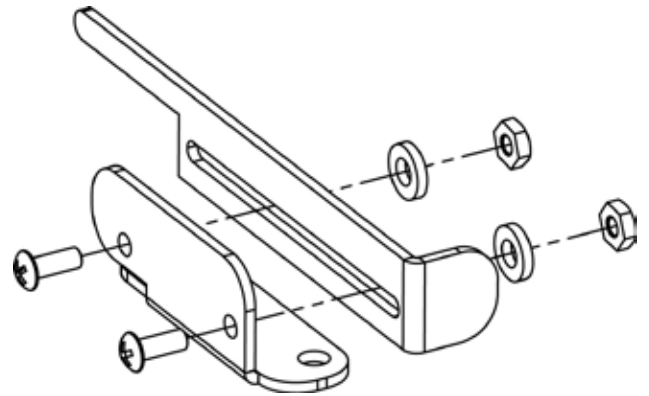
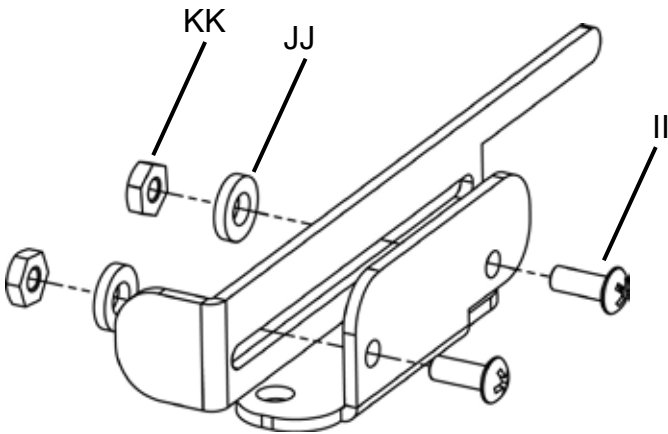

THESE PARTS SHOULD BE PRE-ASSEMBLED. USE THIS STEP IF THEY ARE NOT

STEP 4 - REFERENCE ONLY

Attach the locking bracket and latch plates as shown using screws (II), washers (JJ) and nuts (KK).

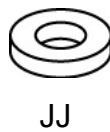
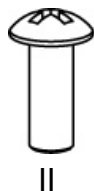

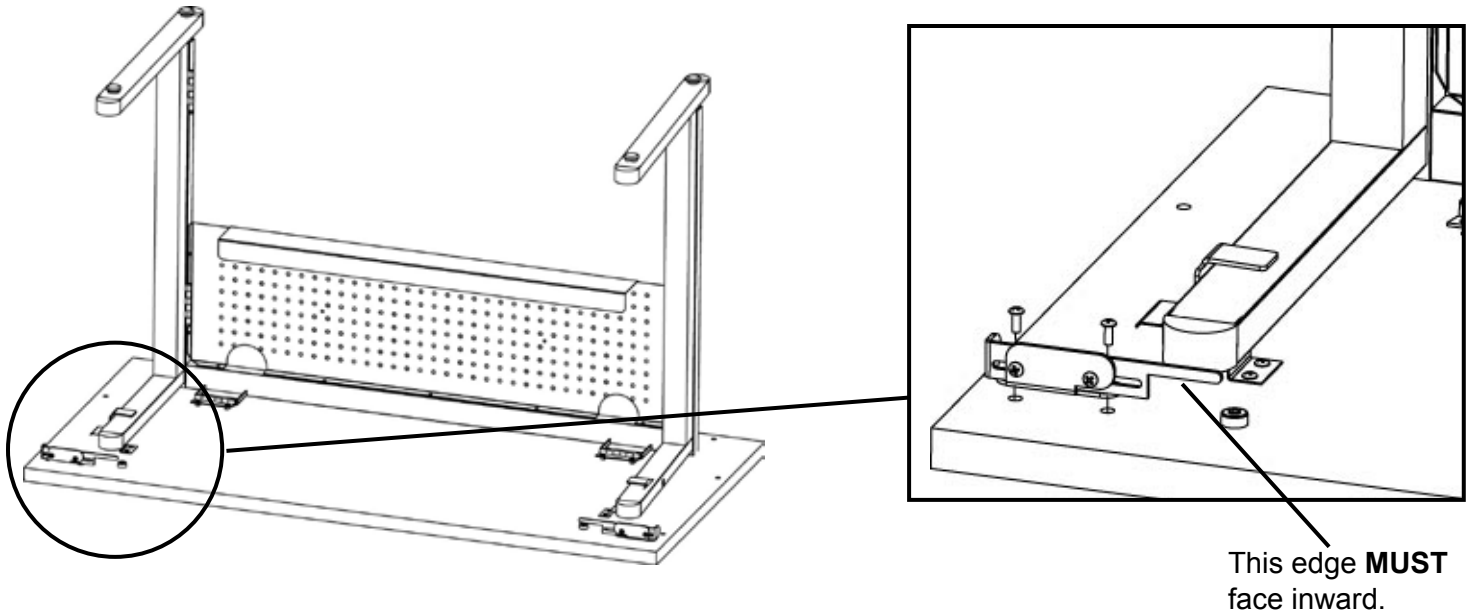

STEP 5

Attach each latch locking assembly to the work surface with screws (HH) as shown.
Make sure the narrow edge faces inside the work surface as shown.

GANGING TABLES TOGETHER

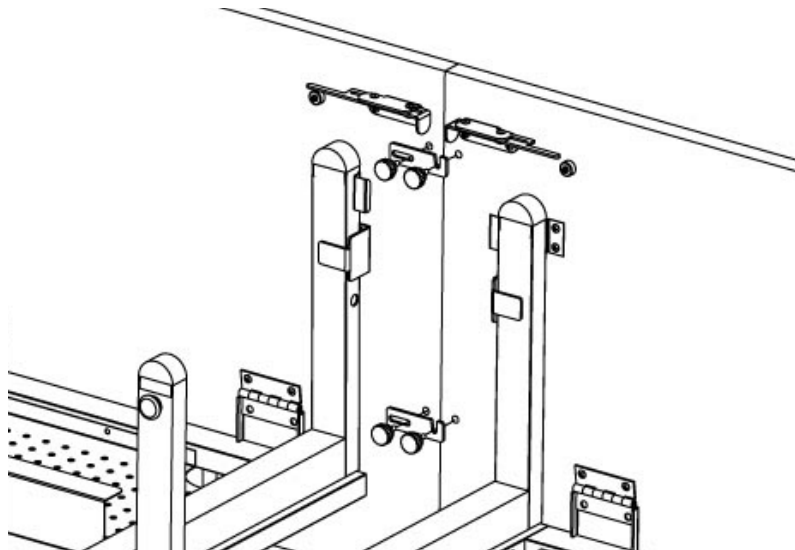

Tables can be ganged together either side to side or back to back. You can do this by attaching the ganging clips and knobs to the underside to the worksurfaces as shown.

NOTE: The tables in the above picture are turned on their side to better show the attachment of the clips and knobs.

Bretford
 11000 Seymour Avenue
 Franklin Park, IL 60131
 TEL: 847.678.2545
 800.521.9614
 FAX: 847.678.0852
 800.343.1779

Bretford Ltd.
 2 Etongate
 110 Windsor Road, Slough
 Berkshire SL1 2JA England
 TEL: 011 44 17 5353 9955
 FAX: 011 44 17 5353 9478