

#34556 Spine Align Chair

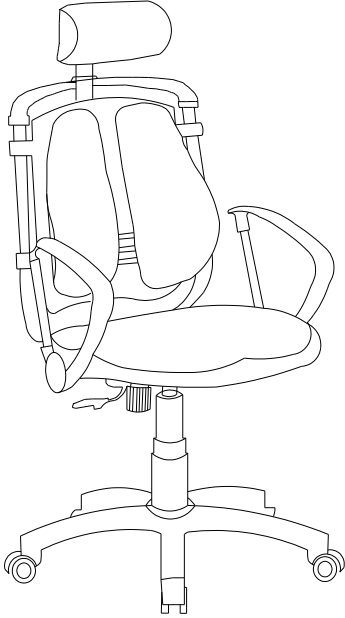

Missing Parts or UPS Damaged Parts

For Your Convenience you can

EMAIL us at

furniture@baltinc.com

24HOURS 7 DAYS A WEEK

Should you require assistance during assembly,

please call our Customer Service

Department Monday - Friday



8 a.m. - 5 p.m.





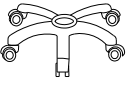

Central Standard Time

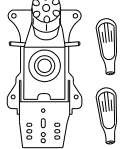
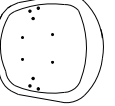
1-800-749-2258





Parts/Hardware



1  1pc	2  1pc	3  5pcs	4  2pcs	5  1pc	6  1pc
---	---	--	--	---	---

7  1head, 1knob	8  2back, 2knob	9  1pc	10  15X35mm 6pcs	11  M6X35mm 6pcs	12  M6X25mm 4pcs
--	--	--	--	--	--

Do not use unless all screws are tight. At least every six months, check all screws to be sure they are tight. If parts are missing, broken, damaged, or worn, stop use of the product until repairs are made by your dealer using factory authorized parts.

13  M8X20mm 3pcs	14  1pc	15  1pc	16  2pc
--	--	--	--

#34556 Spine Align Chair

Step #1

For Detail Caster installation -
See Caster Detail-Page 4.

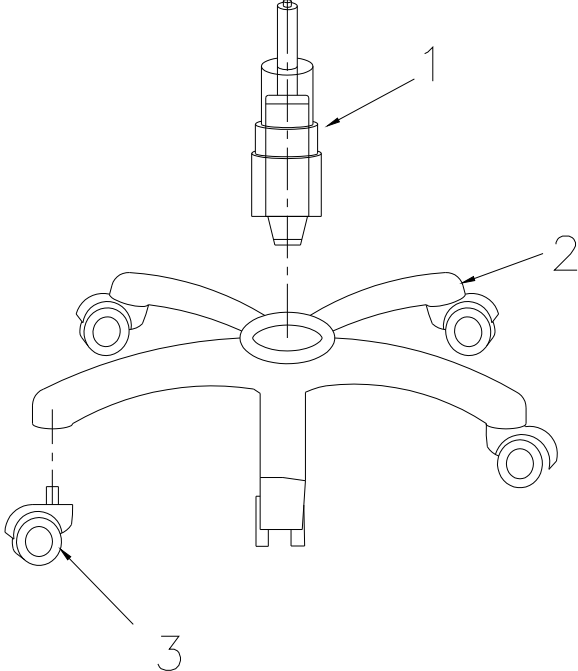

Step #2

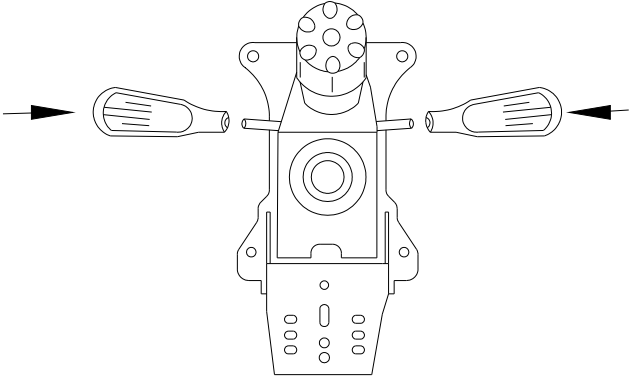

Step #3

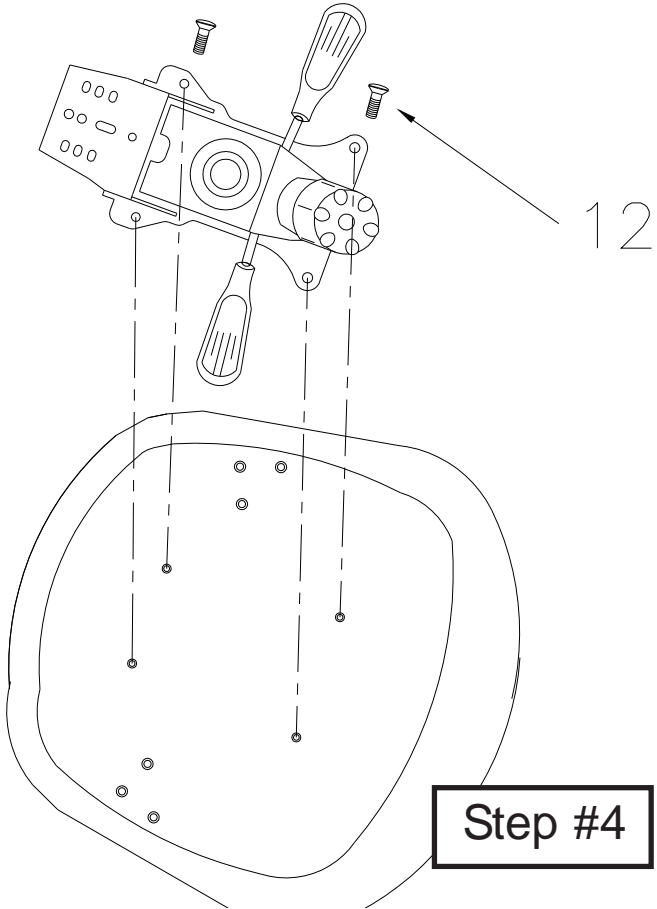
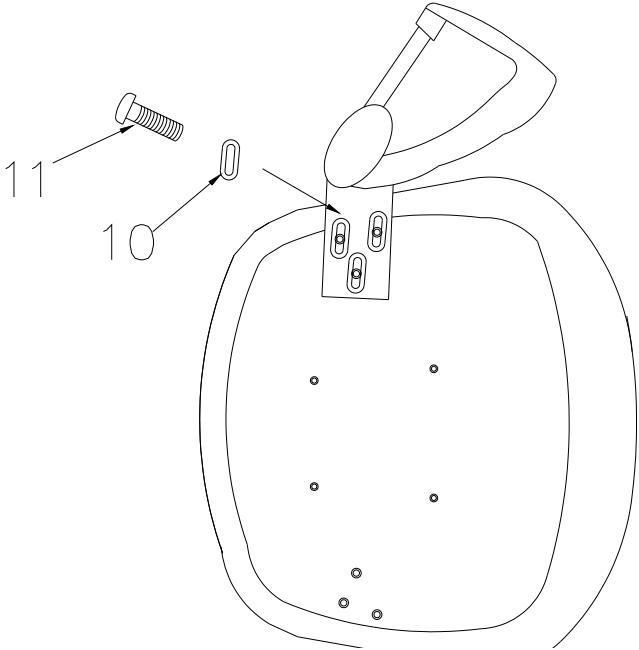

Step #4

#34556 Spine Align Chair

Step #5

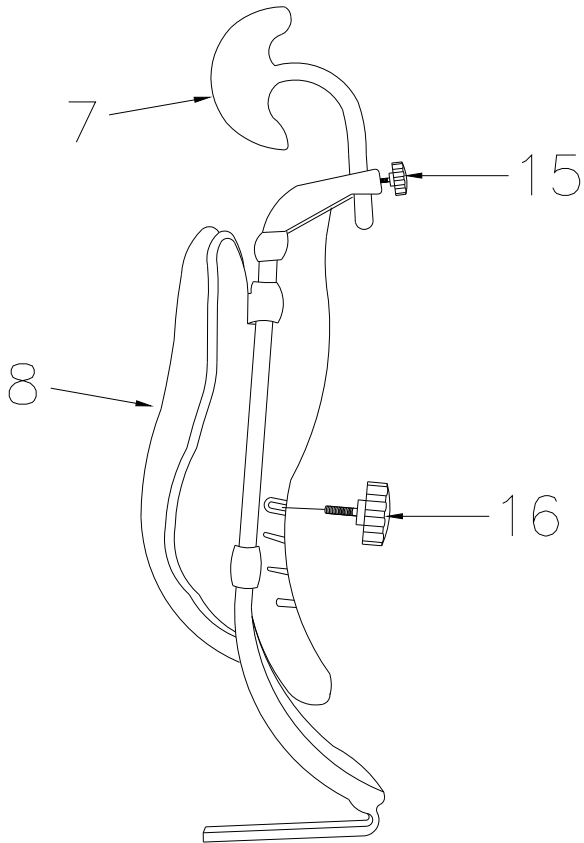

Important

The Balt product you have purchased is guaranteed against material and workmanship defects. This guarantee extends 1 year from date of purchase. Should this product fail to function satisfactorily under normal use due to defect or imperfection, the defective part or product will be replaced. Damage caused by common carriers during shipment is not included in this guarantee.

This guarantee sets forth all applicable guarantees and remedies. No other warranty, expressed or implied shall apply. Failure to follow instructions found in Important Information Section of Owner Sheet shall void the guarantee. Consequential or incidental damages and or costs are not refundable.

Step #6

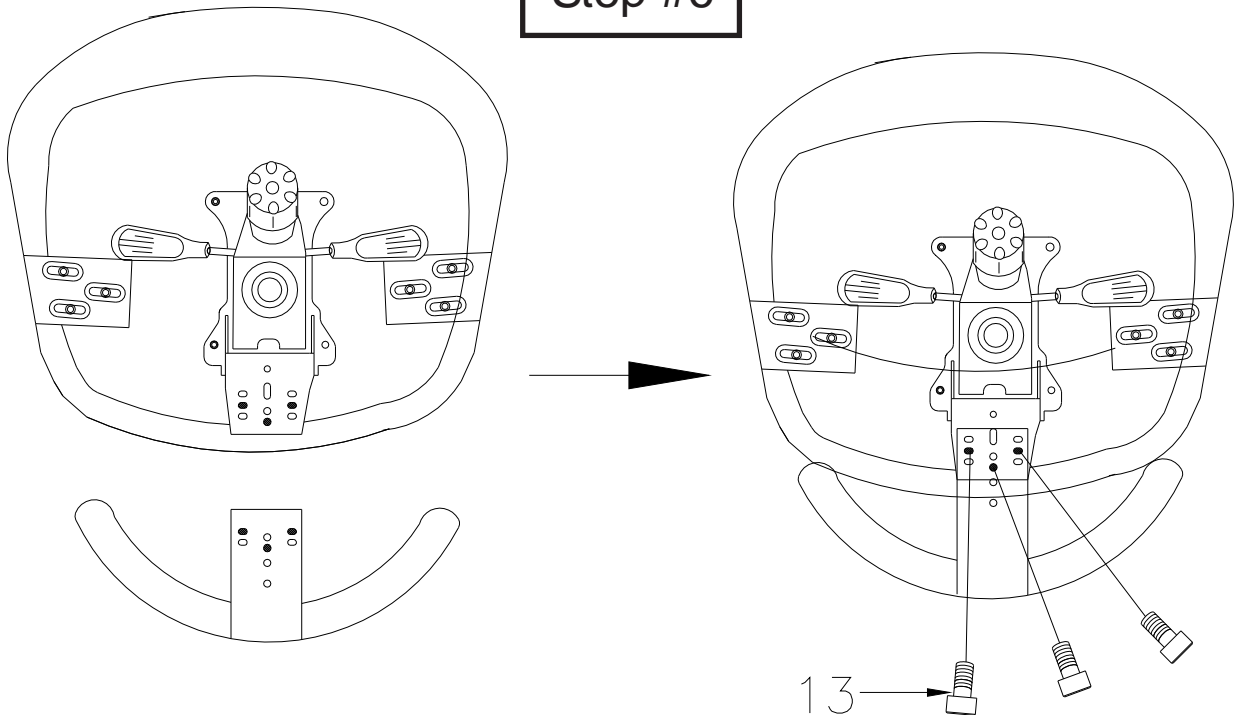

#34556/34571

Caster Installation Detail



Illustration # 1A

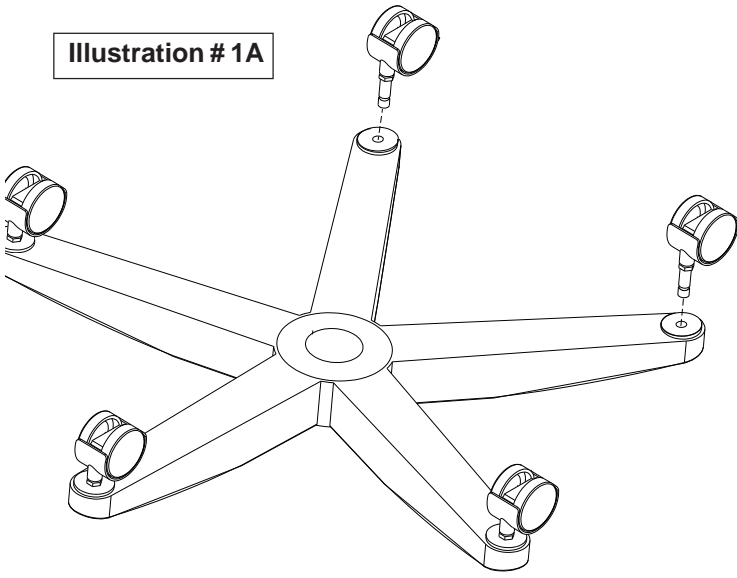

Firmly press 5 Casters in the bottom of chair base as shown in illustration #1.

Turn Chair base over and strike each caster on a flat surface to seat caster.

Illustration # 1B

Hard Flat Surface

