

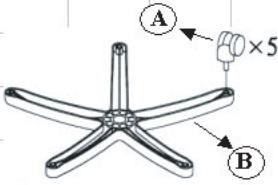

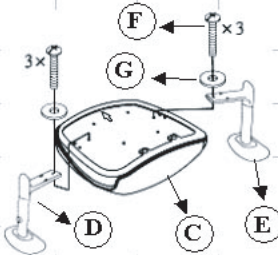

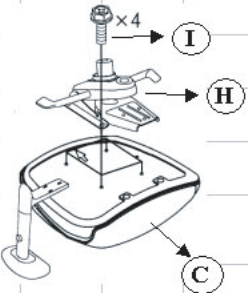







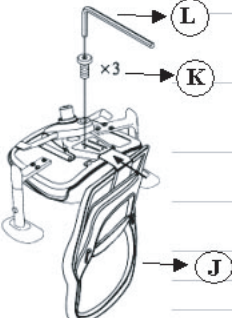
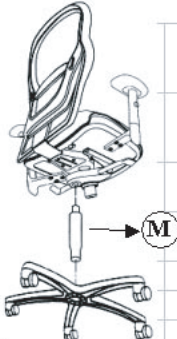

## HIGH BACK MESH CHAIR

Item#: VL701ST 11

Part List				Step 1	Step 2	Step 3			
Key	Description	Qty	Part						
A	CASTER	5		<p>Turn Base "B" upside down. Press Caster "A" into holes of each leg of the base "B"</p> 	<p>Fasten right armrest "D" onto seat cushion "C" with screws "F" and washers "G". Repeat for left armrest "E". NOTE: Arrows on armrests point to front of seat cushion.</p> 	<p>Attach Mechanism "H" onto bottom side of seat cushion with screws "I"</p> 			
B	BASE	1							
C	SEAT CUSHION	1							
D	RIGHT ARMREST	1							
E	LEFT ARMREST	1							
F	ARMREST SCREWS D 1/4" x L 1-3/8"	6							
G	ARMREST WASHER	6							
H	MECHANISM	1					<p><b>Step 4</b></p> <p>Attach backrest "J" to mechanism with screws "K"</p> 	<p><b>Step 5</b></p> <p>Insert gas lift "M" into hole in base</p> 	<p><b>Step 6</b></p> <p>Place seat assembly onto gas lift. Push firmly on the chair seat to securely attach seat assembly to seat post</p> 
I	MECHANISM SCREWS D 5/16" x L 7/8"	4							
J	BACKREST	1							
K	BACK SUPPORT SCREWS D5/16" x L 5/8"	3							
L	ALLEN WRENCH	1							
M	GAS LIFT	1							

**ATTENTION: Make certain that all screws are fully tightened before using chair**