

⚠ WARNING

Failure to install product as instructed, use of hardware other than that which is provided with the product, or failure to comply with all instructions can result in product failure and/or personal injury and/or property damage.

Illustration 1. Panel Connection Guidelines:

IMPORTANT

FOR ADEQUATE STABILITY of the HON Company's Initiate panel freestanding wall partitions, one of two methods of stabilization must be adhered to:

Illustration 1a. Method 1:

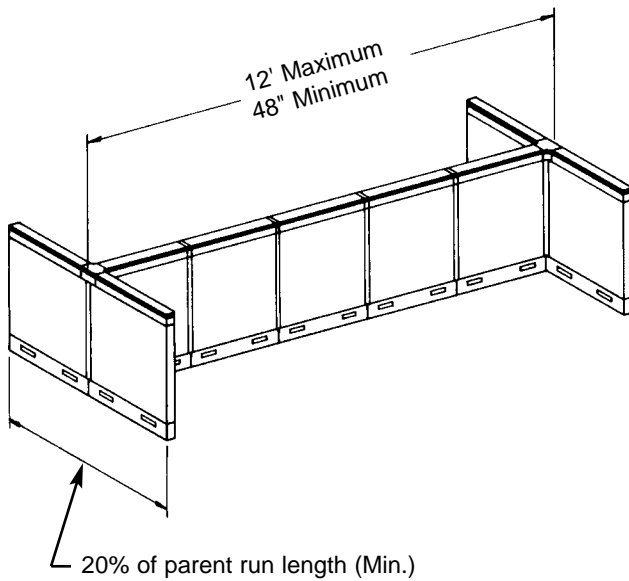

A parent panel run must be a minimum of 48" and a maximum of 12 feet, and must have a minimum of two return panels totaling 20% of the length of parent run extended in opposing directions on each side of the parent run.

DEFINITIONS:

PARENT PANEL RUN - Panels (or a single panel) configured in a straight line intended to divide space. It is usually longer than the panels used to stabilize it.

RETURN PANELS - Panels attached to a parent run for the purpose of stabilizing it. Return panels may also have the effect of dividing space.

Illustration 1b. Method 2:

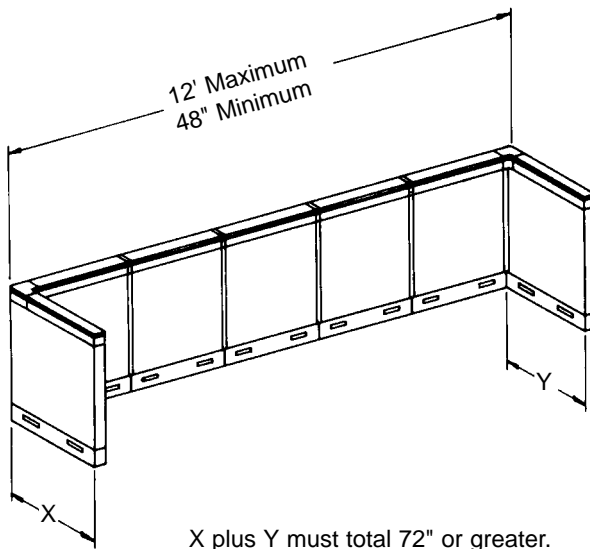

A parent panel run must be a minimum of 48" and a maximum of 12 feet, and must have at least two return panels each with a minimum length of 36".

DEFINITIONS:

PARENT PANEL RUN - Panels (or a single panel) configured in a straight line intended to divide space. It is usually longer than the panels used to stabilize it.

RETURN PANELS - Panels attached to a parent run for the purpose of stabilizing it. Return panels may also have the effect of dividing space.

Illustration 2. Overhead Storage Unit Guidelines:

Illustration 2a. Guideline 1:

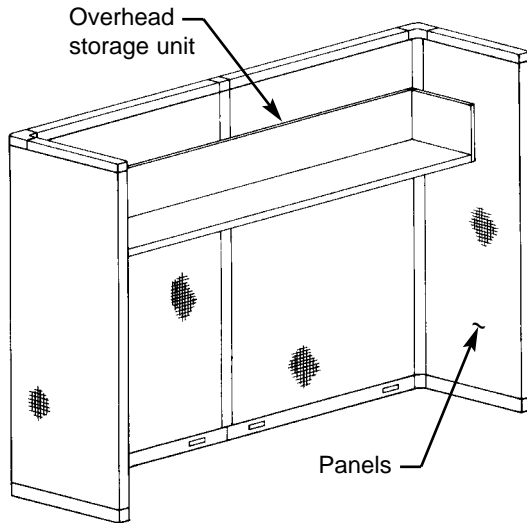

Units must be suspended on panels of a corresponding width, or suspended across two panels with a combined width equal to the storage unit width.

Illustration 2b. Guideline 2:

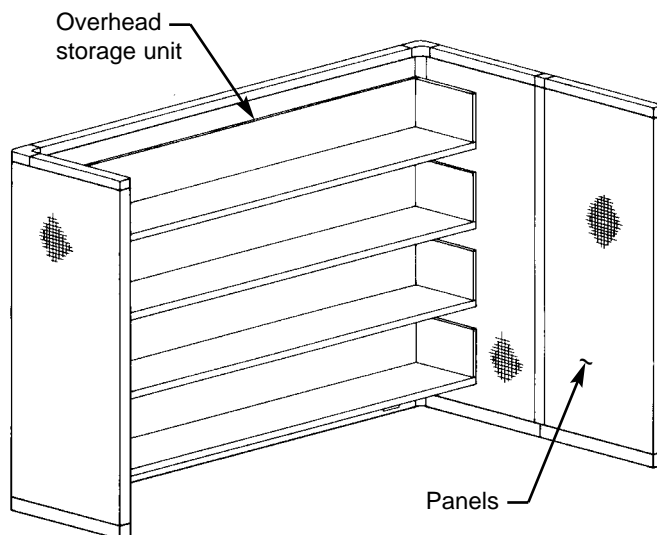

⚠ WARNING

Excessive or concentrated loads can cause a shelf or panel to collapse causing injury. Do not install more than 10 shelves onto a panel and do not put more than 300 lb. of evenly distributed load onto each shelf.

More than two storage units can be suspended from a single panel **only** if return panels are positioned at each end of the storage units.

Illustration 3. Inline Panel Connection:

Illustration 3a. Vertical Connector Installation:

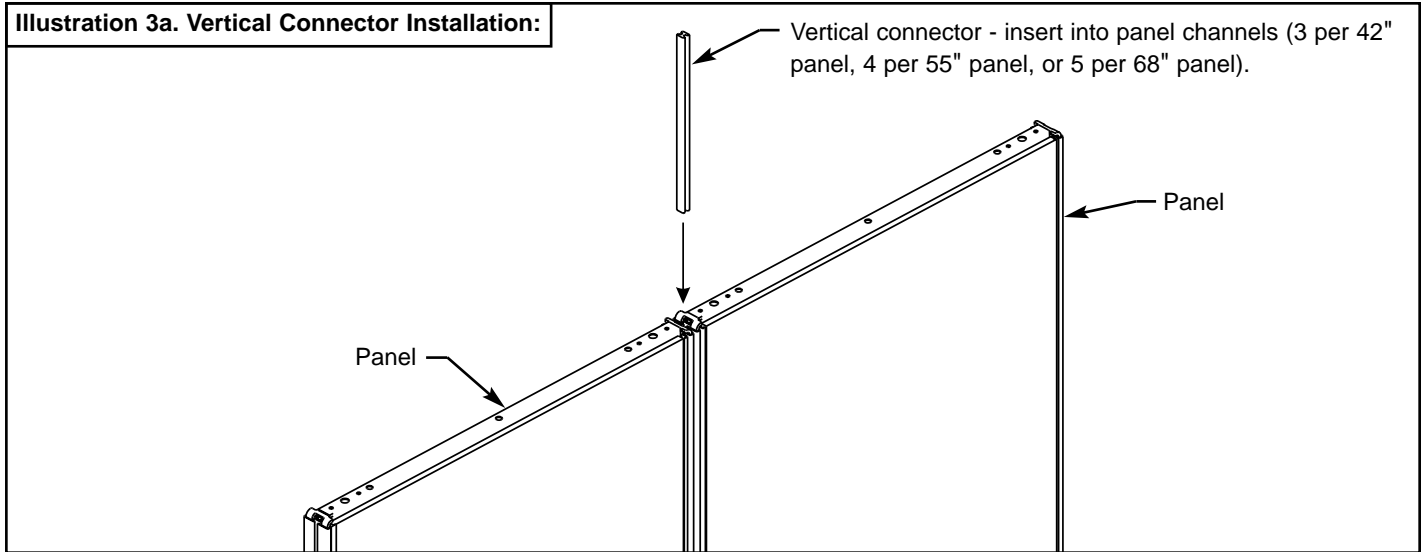

Illustration 3b. Top Bracket Installation:

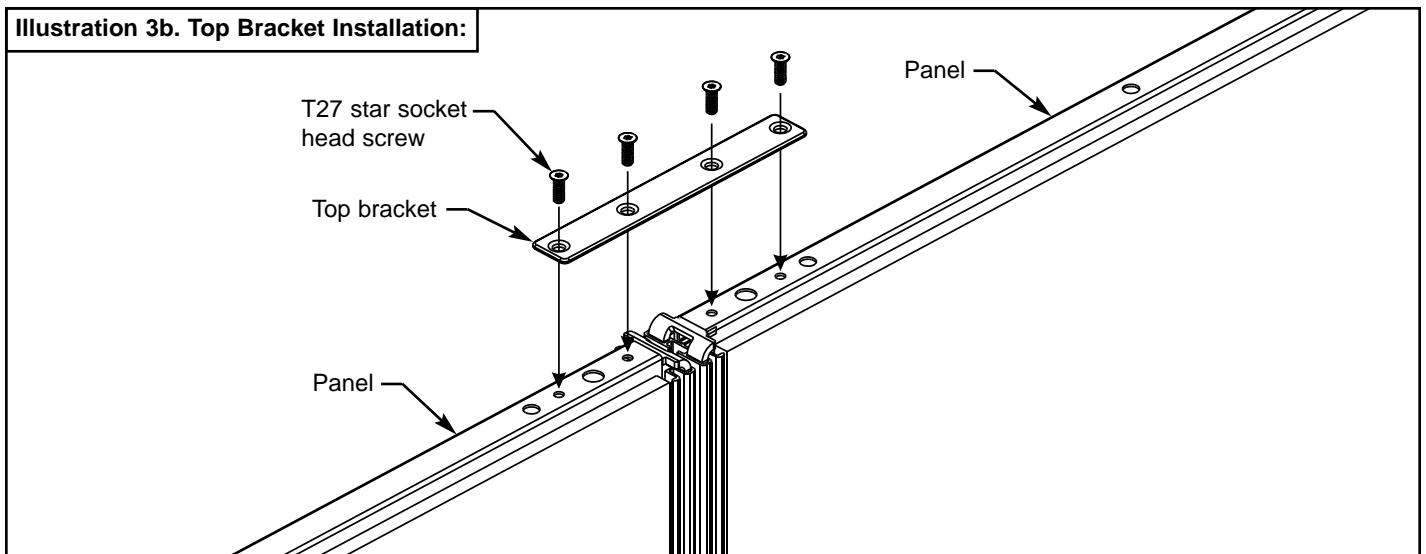

Illustration 3c. Top Cap Installation:

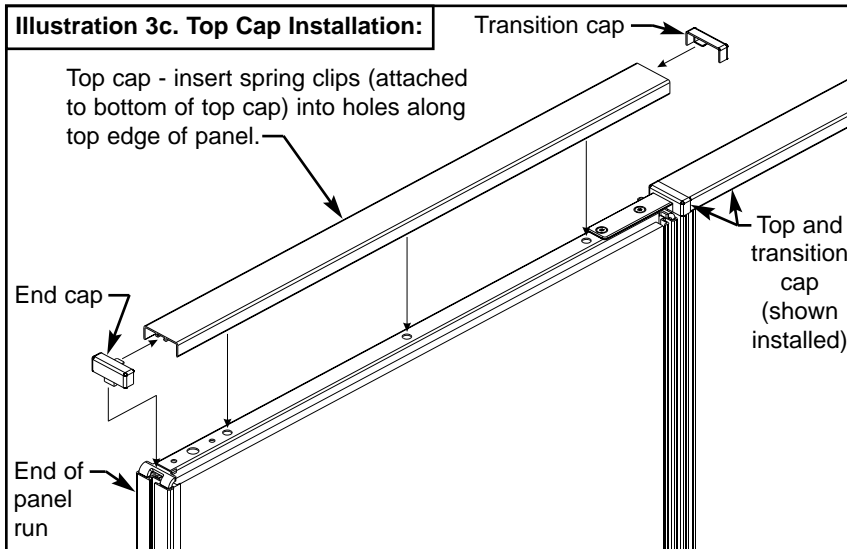

Illustration 3d. Base Rail End Cap Installation:

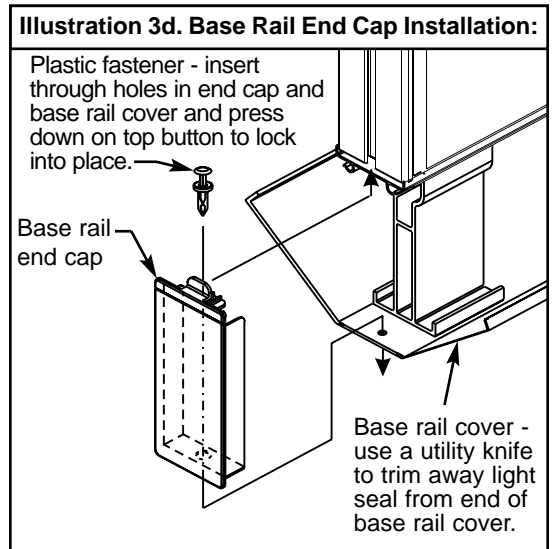

Illustration 4. Corner, Tee, and Cross Connection:

Illustration 4a. Universal Connector Installation:

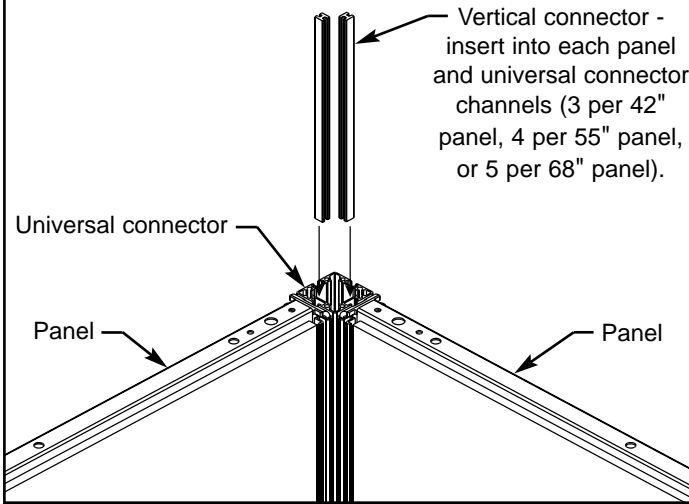

Illustration 4b. Universal Connector Bracket Installation:

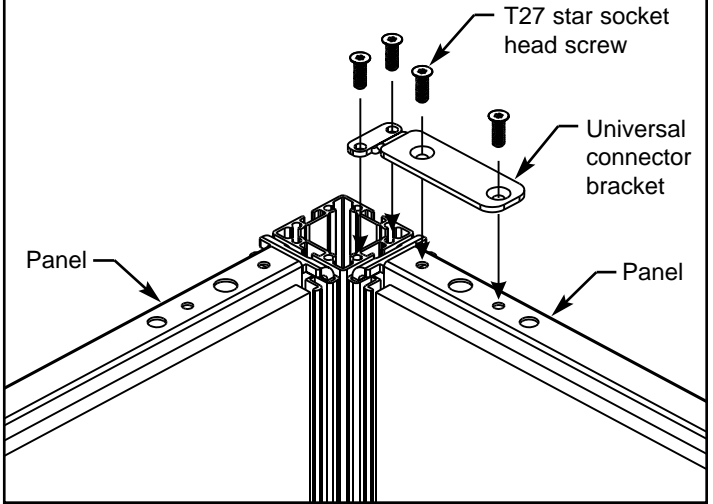
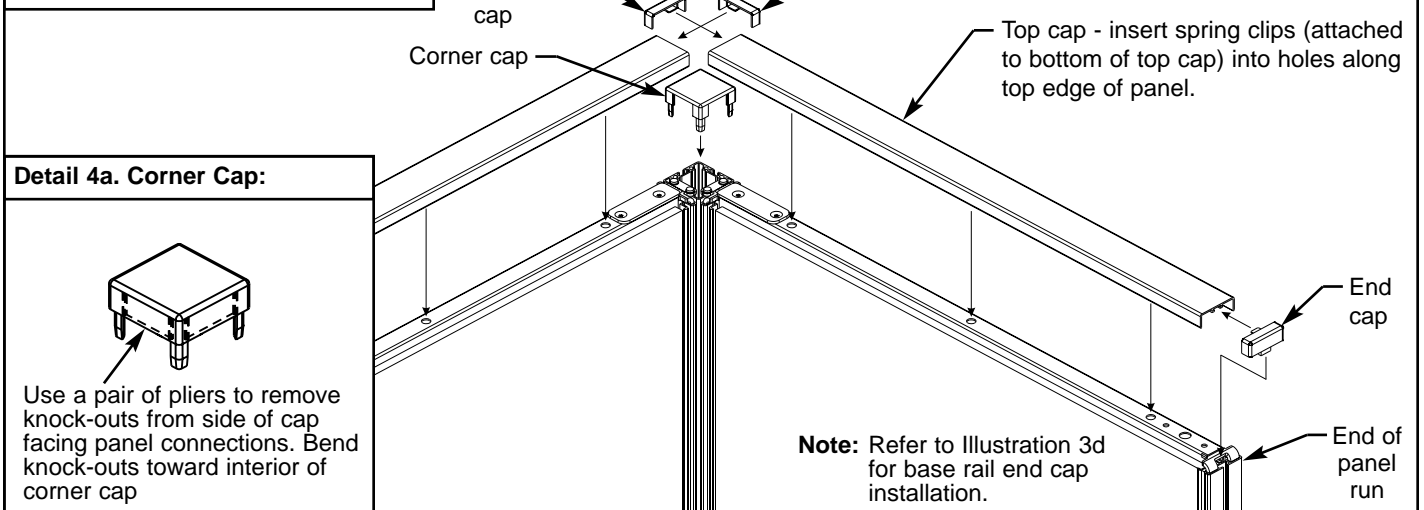

Illustration 4c. Top Cap Installation:



Detail 4a. Corner Cap:

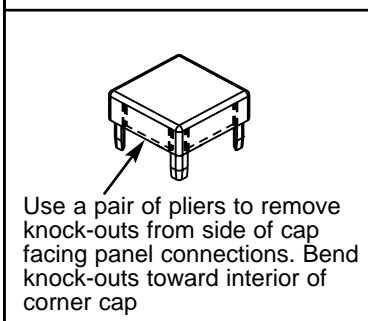

Illustration 4d. Corner Base Cap Installation:

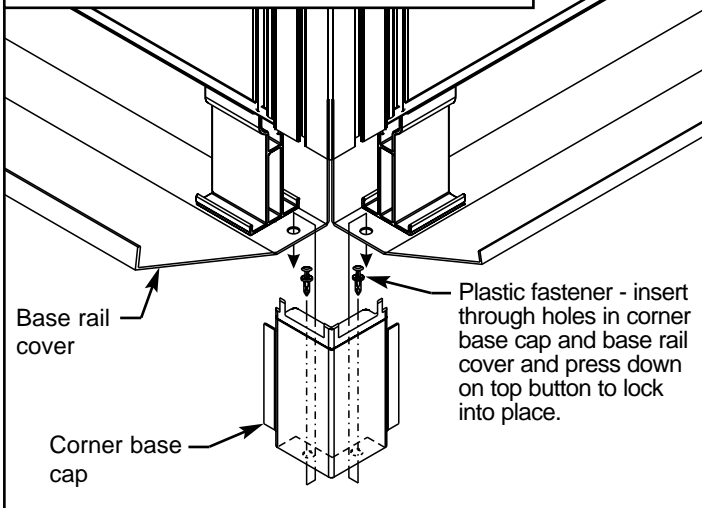

Illustration 4e. Extended Straight Base Cap Installation:

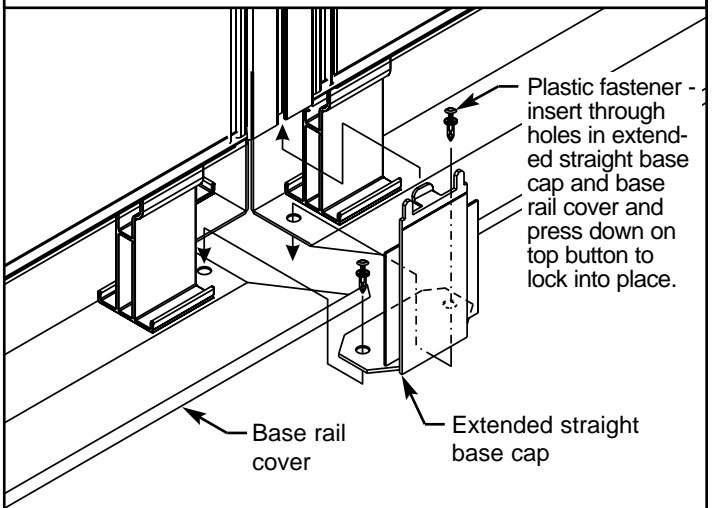

Illustration 5. Variable Height Connection:

Illustration 5a. Universal Connector Installation:

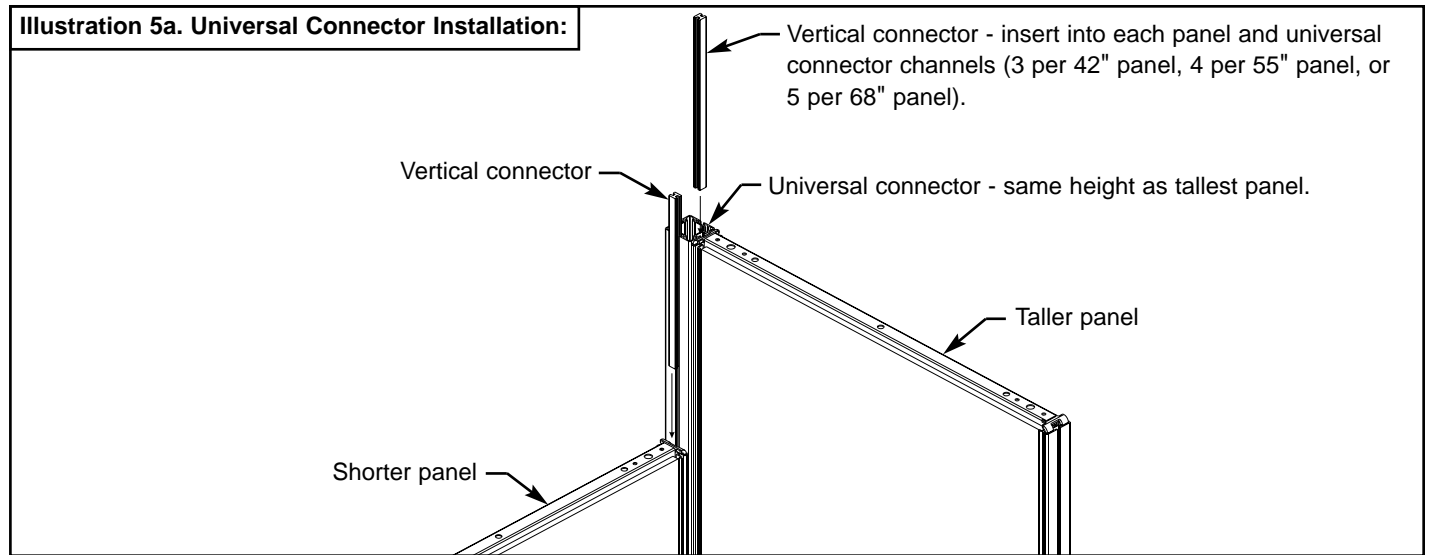

Illustration 5b. Universal Connector and Variable Height Bracket Installation:

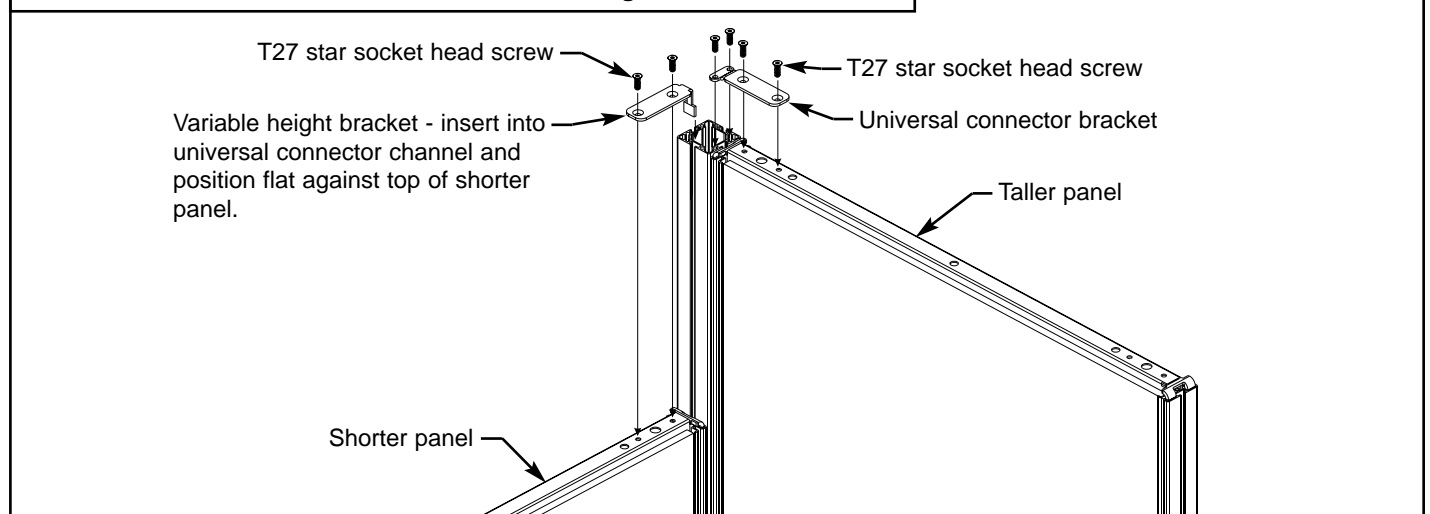
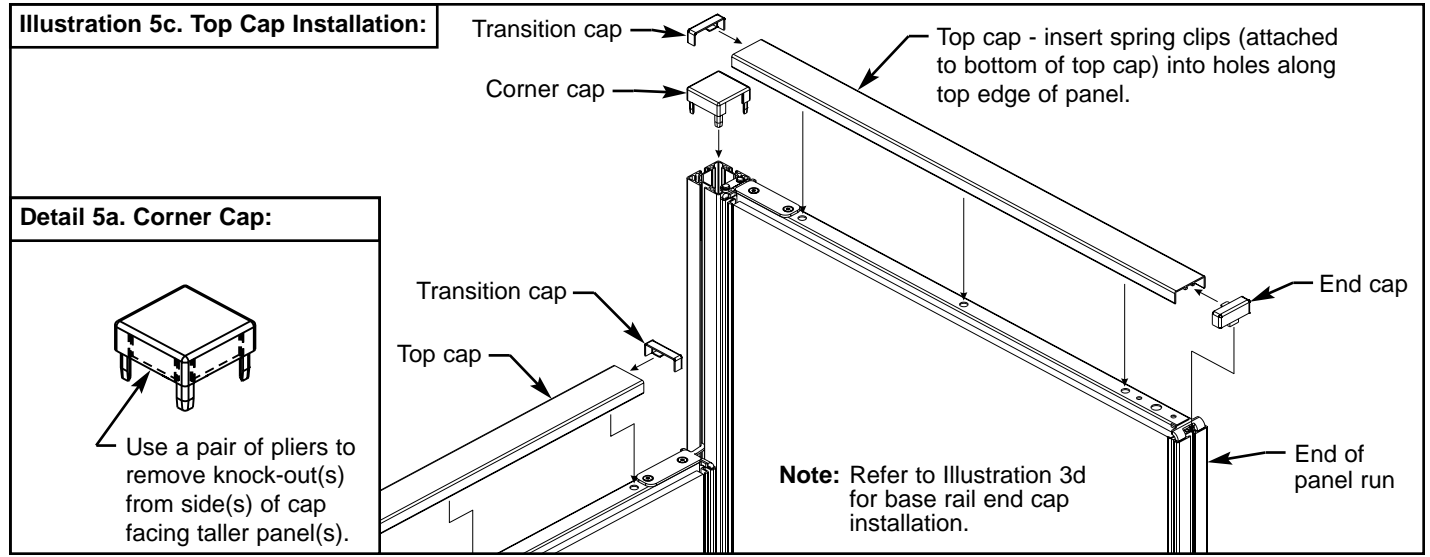

Illustration 5c. Top Cap Installation:



Detail 5a. Corner Cap:

