

# OCCASIONAL TABLE

Illustration 1

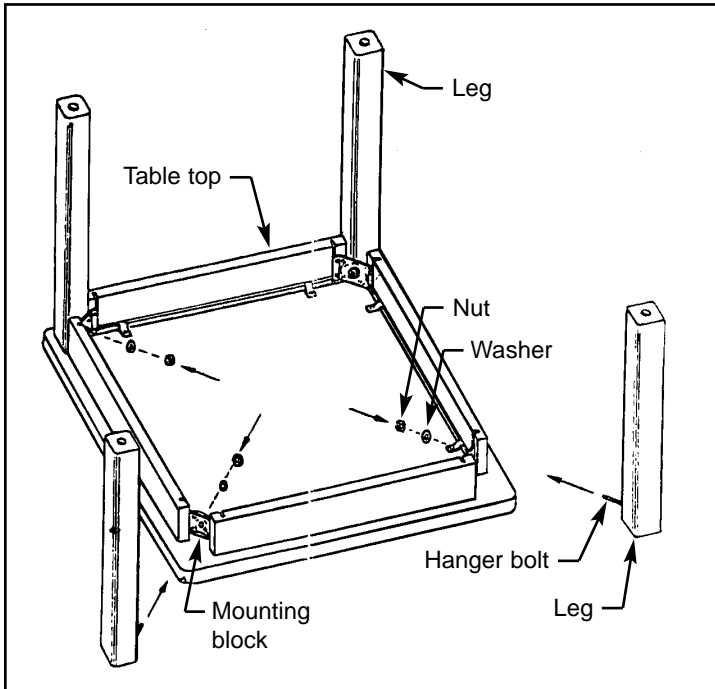

Read all instructions and review illustrations before installing.

Tools required for assembly:

$\frac{7}{16}$ " wrench

This assembly includes:

(1) Table top	(4) Leg
(4) Washer	(4) Nut

**Installation (refer to Illustration 1):**

1. Lay table top, bottom side up, on cardboard or a carpeted surface. This is to prevent damage to the top finish.
2. Locate mounting block attached to each corner of table top.
3. Remove protective cover from a leg hanger bolt and position leg against a mounting block as shown. Insert leg hanger bolt through hole in mounting block.
4. Install a washer and nut (from hardware pack) onto end of leg hanger bolt. Use the  $\frac{7}{16}$ " wrench to tighten nut. **DO NOT** over-tighten nut or product damage may occur.
5. Repeat Steps 4 and 5 for remaining legs.
6. Set table upright and position table where it will be used.

INSTALLATION INSTRUCTIONS