

Aruba 6300F/M Switch Series Installation and Getting Started Guide

The Aruba logo consists of the word "aruba" in a lowercase, rounded, orange sans-serif font. The letters are closely spaced, and the 'a' and 'u' have a distinctive shape with a small gap at the top.

a Hewlett Packard
Enterprise company

Copyright Information

© Copyright 2021 Hewlett Packard Enterprise Development LP.

Open Source Code

This product includes code licensed under the GNU General Public License, the GNU Lesser General Public License, and/or certain other open source licenses. A complete machine-readable copy of the source code corresponding to such code is available upon request. This offer is valid to anyone in receipt of this information and shall expire three years following the date of the final distribution of this product version by Hewlett Packard Enterprise Company. To obtain such source code, send a check or money order in the amount of US \$10.00 to:

Hewlett Packard Enterprise Company
6280 America Center Drive
San Jose, CA 95002
USA

Notices

The information contained herein is subject to change without notice. The only warranties for Hewlett Packard Enterprise products and services are set forth in the express warranty statements accompanying such products and services. Nothing herein should be construed as constituting an additional warranty. Hewlett Packard Enterprise shall not be liable for technical or editorial errors or omissions contained herein. Confidential computer software. Valid license from Hewlett Packard Enterprise required for possession, use, or copying. Consistent with FAR 12.211 and 12.212, Commercial Computer Software, Computer Software Documentation, and Technical Data for Commercial Items are licensed to the U.S. Government under vendor's standard commercial license.

Links to third-party websites take you outside the Hewlett Packard Enterprise website. Hewlett Packard Enterprise has no control over and is not responsible for information outside the Hewlett Packard Enterprise website.

Acknowledgments

Microsoft® and Windows® are either registered trademarks or trademarks of Microsoft Corporation in the United States and/or other countries.

UNIX® is a registered trademark of The Open Group.

Contents	3
About this document	5
Applicable products	5
Related publications	5
Introducing the switches	6
Front of the switches	6
Network ports	9
Management ports	9
Console port	9
Auxiliary port	9
Switch and port LEDs on front of the switches	10
LED mode select button and indicator LEDs	12
Reset buttons	12
Out-of-band management port	12
Back of the switches	13
Fan requirements	13
Power supplies	14
Power connector	15
LEDs on the back of the switches	15
Switch features	16
Installing the switch	19
Shipping the switch in a rack	19
Included parts	19
Installation procedures for 6300 switches	20
Installation precautions and guidelines	21
Prepare the installation site	22
Install a power supply or a second power supply for modular switches	23
Verify the switch boots correctly	27
Disconnect power from the switch	28
Mount the switch	28
Mounting a switch on a tabletop or desktop	28
Mounting the switch in a two-post rack	29
Mounting the switch in a four-post rack	30
Connect the switch to a power source	30
Install transceivers (optional)	30
Connect network cables	31
SFP/SFP+/SFP28/SFP56 installation notes	32
Sample network topologies	33
Getting started with switch configuration	36
Recommended minimal configuration	36
Setup for initial configuration	36
Replacing components	37
Replacing the fan	37

Replacing the power supply	38
Troubleshooting	41
Basic troubleshooting tips	41
Diagnosing with the LEDs	42
Proactive networking	47
Hardware diagnostic tests	47
Testing the switch by resetting it	47
Checking the switch LEDs	48
Checking console messages	48
Testing twisted-pair cabling	48
Testing switch-to-device network communications	48
Testing end-to-end network communications	48
Restoring the factory default configuration	49
Downloading new switch software	49
Specifications	50
Physical and environmental	50
Electrical	51
Acoustics	52
Safety	53
Connectivity standards	54
Cabling and technology information	56
Cabling specifications	56
Technology distance specifications	58
Mode conditioning patch cord	59
Installing the patch cord	60
Twisted-pair cable/connector pin-outs	60
Straight-through twisted-pair cable for 10 Mbps or 100 Mbps network connections	61
Crossover twisted-pair cable for 10 Mbps or 100 Mbps network connection	62
Straight-through twisted-pair cable for 1000 Mbps network connections	63
Support and Other Resources	65
Accessing Aruba Support	65
Accessing Updates	65
Aruba Support Portal	66
My Networking	66
Warranty Information	66
Regulatory Information	66
Documentation Feedback	66

This document is intended for network administrators and support personnel.



The display and command line illustrated in this document are examples and might not exactly match your particular switch or environment.

The switch and accessory drawings in this document are for illustration only, and may not exactly match your particular switch and accessory products.

Applicable products

Modular PoE	Modular Non-PoE
JL659A Aruba 6300M 48SR5 CL6 PoE 4SFP56 Swch	JL658A Aruba 6300M 24SFP+ 4SFP56 Swch
JL660A Aruba 6300M 24SR5 CL6 PoE 4SFP56 Swch	JL663A Aruba 6300M 48G 4SFP56 Swch
JL661A Aruba 6300M 48G CL4 PoE 4SFP56 Swch	JL664A Aruba 6300M 24G 4SFP56 Swch
JL662A Aruba 6300M 24G CL4 PoE 4SFP56 Swch	JL762A Aruba 6300M 48G Pwr2Prt 2F 1PS Bdl

Fixed PoE	Fixed Non-PoE
JL665A Aruba 6300F 48G CL4 PoE 4SFP56 Swch	JL667A Aruba 6300F 48G 4SFP56 Swch
JL666A Aruba 6300F 24G CL4 PoE 4SFP56 Swch	JL668A Aruba 6300F 24G 4SFP56 Swch

Related publications

- *Start Here: Installation, Safety, and Regulatory Information for the Aruba 6300F/M Switches and Accessories*
- *Start Here: Installation, Safety, and Regulatory Information for the Aruba Modular Power Supplies*
- *Start Here: Installation, Safety, and Regulatory Information for the Aruba DC Modular Power Supplies*
- AOS-CX software manuals
- *AOS-CX Power Over Ethernet (PoE/PoE+) Planning and Implementation Guide*
- *AOS-Switch and AOS-CX Transceiver Guide*

To view and download these publications, visit the Aruba Support Portal at <https://asp.arubanetworks.com/downloads>.

Aruba multiport switches are store-and-forward devices offering low latency for high-speed networking. Certain switch models also support Power over Ethernet (PoE) technologies and full network management capabilities.

This chapter describes these switches with the following information:

- Front of the switches:
 - Network ports
 - Management ports
 - LEDs
 - Buttons
 - Out-of-Band Management (OOBM)
 - SFP/SFP+/SFP28/SFP56 support
- Back of the switches:
 - Power supplies and power connectors
 - Fan tray and replaceable power supplies (modular switches)
- Switch features

Front of the switches

Figure 1 *Front of all the 6300 Switches*

1

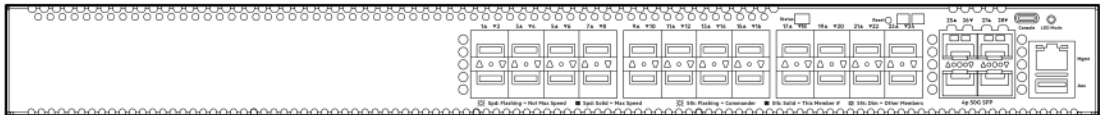

2

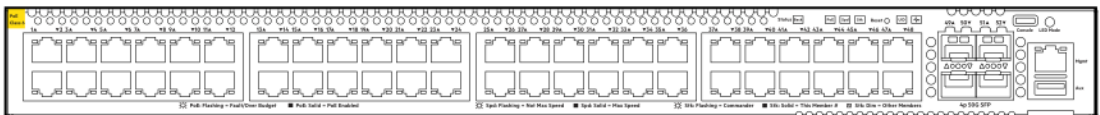

3

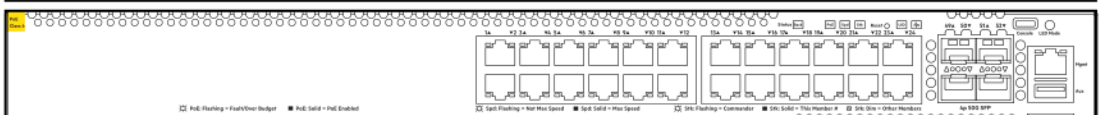

4

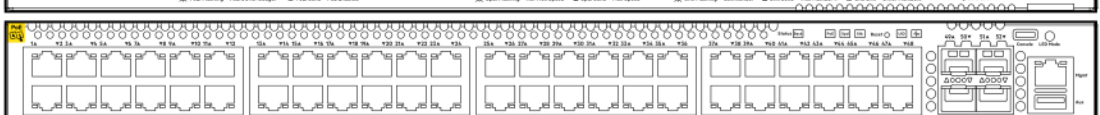

5

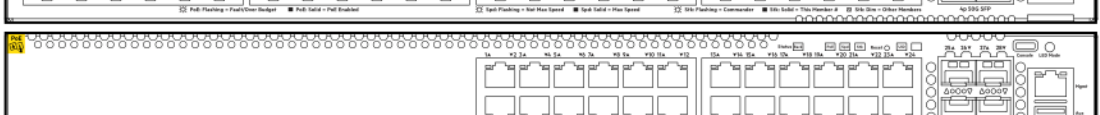

6

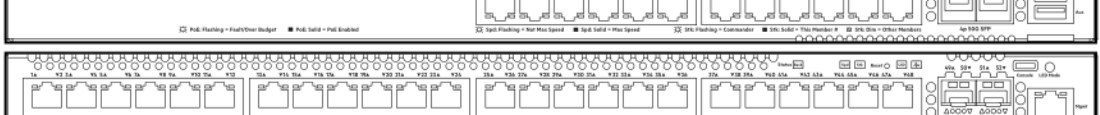

7

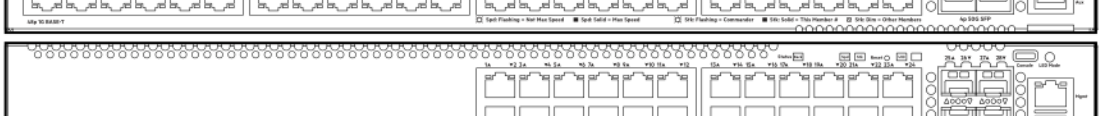

8



9



10

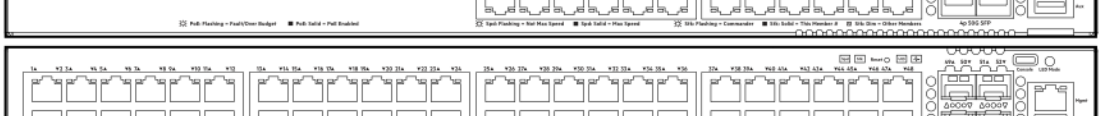

11



Table 1: Front of all the 6300 switches: Label and description

Label	Description
1	JL658A Aruba 6300M 24G 24SFP+ 4SFP56
2	JL659A Aruba 6300M 48SR5 CL6 PoE 4SFP56
3	JL660A Aruba 6300M 24SR5 CL6 PoE 4SFP56
4	JL661A Aruba 6300M 48G CL4 PoE 4SFP56
5	JL662A Aruba 6300M 24G CL4 PoE 4SFP56

Label	Description
6	JL663A Aruba 6300M 48G 4SFP56 and JL762A Aruba 6300M 48G Pwr2Prt 2F 1PS Bdl
7	JL664A Aruba 6300M 24G 4SFP56
8	JL665A Aruba 6300F 48G CL4 PoE 4SFP56
9	JL666A Aruba 6300F 24G CL4 PoE 4SFP56
10	JL667A Aruba 6300F 48G 4SFP56
11	JL668A Aruba 6300F 24G 4SFP56

Figure 2 Example of 6300 Switch

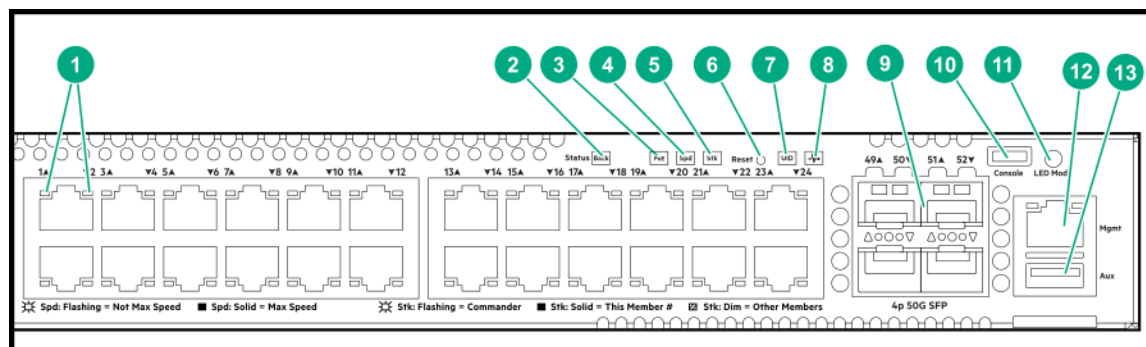

Table 2: 6300 Switches: Labels and Description

Label	Description
1	Switch Port LEDs
2	Back Module status LED
3	PoE1
4	Speed LED
5	Stk LED
6	Reset button
7	Unit Identification LED
8	Global Status LED
9	SFP56 ports
10	USB-C Console
11	LED Mode button

1PoE Mode LED is present only on switch models that support PoE.

Label	Description
12	Out-of-Band Management port
13	USB/auxiliary port

PoE Mode LED is present only on switch models that support PoE.

Network ports

Table 3: Network Ports

Switch	10/100/1000 BaseT PoE CL4	10/100/1000 BaseT	1/10/25/50GbE SFP	Smart Rate 100M/1G/2.5G/5G PoE CL6	SFP+
JL658	-	-	4	-	24
JL659	-	-	4	48	-
JL660	-	-	4	24	-
JL661	48	-	4	-	-
JL662	24	-	4	-	-
JL663	-	48	4	-	-
JL664	-	24	4	-	-
JL665	48	-	4	-	-
JL666	24	-	4	-	-
JL667	-	48	4	-	-
JL668	-	24	4	-	-
JL762	-	48	4	-	-



For supported transceivers, see the latest version of the *Transceiver Guide* on the Aruba Support Portal.

Management ports

Console port

There is a single serial console port on the switch, using a USB Type-C connector. This port is used to connect a console to the switch. Use a common USB to USB-C cable (must be data capable). A Bluetooth dongle is available to provide an alternative way of managing and configuring your switch using a mobile app.

The console can be a PC or workstation running a VT-100 terminal emulator, or a VT-100 terminal.

Auxiliary port

An auxiliary port is available for downloading switch software code. This port uses a USB Type-A connector.

Switch and port LEDs on front of the switches

Figure 1 Switch and port LEDs

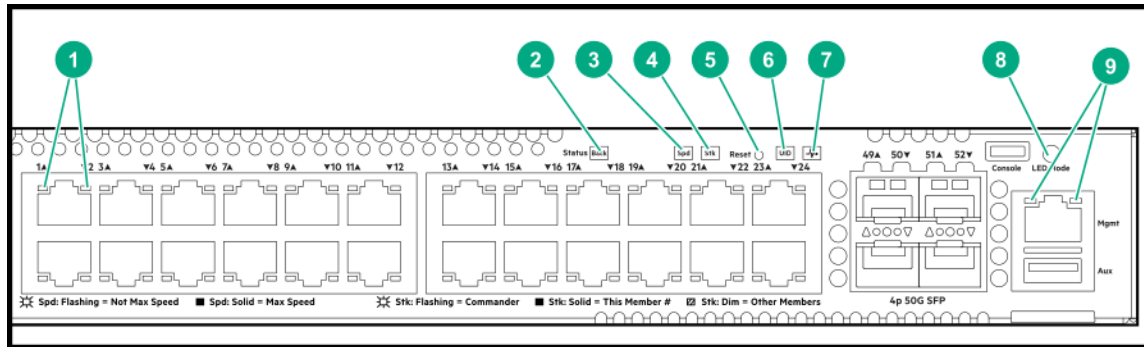

Table 4: Switch and Port LEDs: Labels and Description

Label	Description
1	Switch port LEDs
2	Back Module status LED
3	Speed mode selected LED
4	Stk LED S
5	Reset button
6	UID (Unit Identification)
7	Global Status LED
8	Mode select button
9	OOBM port LED

Table 5: Front Panel LED Behavior

Switch LEDs	Function	State	Meaning
Back LED	Status of modular components installed in the back of the chassis (not applicable for 6300F switches)	On - Green	Normal
		Slow Flash - Amber	Fault in one of the modules in the back of the chassis
PoE LED	Indicates Port LEDs are showing PoE information (not applicable for non PoE switches)	Off	PoE mode not selected
		On - Green	PoE mode selected
		Slow Flash - Amber	One or more ports experiencing PoE failure. PoE mode not selected.
		On - Amber	One or more ports experiencing PoE failure. PoE mode selected.

Switch LEDs	Function	State	Meaning
Spd LED	Indicates Port LEDs are showing speed information	Off	Speed mode not selected
		On - Green	Speed mode selected
		Not Implemented	No fault defined
Stk LED	Indicates Port LEDs are showing stacking mode information	Off	Stacking mode not selected
		On - Green	Stacking mode selected
		On - Amber	One of the switch is experiencing stacking failure. Port LEDs will be used to indicate the number of the stacking member.
		Slow flash Amber	A port has a stacking failure. Stacking mode not selected
UID LED	Locator LED	Off	User configured the located LED : OFF
		On/Flash Blue (for 30 min)	User configured the locator LED: On/Flash
Global Status Indicator LED	Overall status of the product	Flash - Green	Self-test in progress during UBOOT and SVOS
		On - Green	Successfully booted AOS-CX
		Flash - Amber	Recoverable faults (e.g. fans, PSU fault)
		On - Amber	Critical faults (e.g. exceed temperature limit)
		Snoring (Dim - Bright periodically)	System is in hibernation
OOBM Status Indicator LED	Status of OOBM Link connectivity	Off	OOBM port is not connected, no link established
		Half Bright - Green	OOBM port is enabled and established link with partner
		On - Green	Experiencing high bandwidth utilization
		Activity Flicker - Green	% of the time that the LED light up is roughly proportional to the % of full bandwidth utilization of the port
* Press the Mode Select button to switch between PoE, Spd, or Stk Mode.			

Table 6: Rear Panel LED Behavior

Switch LEDs	Function	State/Mode	Meaning
Fan health LED	Status of fan	On - Green	Normal
		Slow flash - Amber	Fan fault
UID LED	Locator LED	Off	User configured the locator LED : OFF
		On/Flash (30 min) - blue	User configured the locator LED: On/Flash
PSU Status Indicator LED	Status of power supply	On Green	Normal
		Off	No power, PSU has invalid AC or DC input or invalid DC output
		Slow Flash - Green	Power supply has faulted

LED mode select button and indicator LEDs

The state of the switch port LEDs is controlled by the LED Mode select button. The current view mode is indicated by the mode LEDs next to the button. To step from one view mode to the next, press the button to cycle through the different modes.

Reset buttons

The Reset button is recessed from the front panel. (This design protects it from being pushed accidentally.) The button is accessible through small holes on the top of the front panel. Use pointed objects, such as unbent paper clips, to push it.

To Accomplish this:	Do this:	This will happen:
Soft reset	Press and release the Reset button.	The switch operating system is cleared gracefully. The switch then reboots and runs self-tests.
Hard reset	Press and hold the Reset button for more than 5 seconds, then release.	The switch reboots, similar to a power cycle. A hard reset is used, for example, when the switch CPU is in an unknown state or not responding.

Out-of-band management port

This RJ-45 port is used to connect a dedicated management network to the switch. To use it, connect an RJ-45 network cable to the management port to manage the switch through Telnet from a remote PC or a UNIX workstation.

To use this port, the switch must have an IP address. IP settings can be configured through a console port connection or automatically from a DHCP/Bootp server.

A networked out-of-band connection through the management port allows you to manage data network switches from a physically and logically separate management network.

For more information, see the *Fundamentals Guide* for your switch, found on the Aruba Support Portal.

Back of the switches

Figure 1 Back of the 6300M Switch

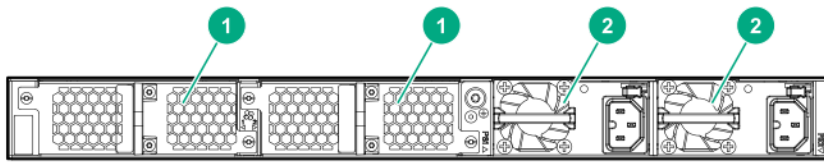

Table 7: Back of the 6300 Switch: Label and Description

Label	Description
1	Fan tray 1 & 2
2	Power supply slot 1 & 2

Fan requirements

Switches	Fan Tray 1	Fan Tray 2
JL658A	Required	Required
JL659A	Required	Required
JL663A	Required	Optional
JL664A	Required	Optional
JL660A	Required	Optional
JL661A	Required	Optional
JL662A	Required	Optional
JL762A	Required	Required

For JL660A, JL661A, JL662A, JL663A, and JL664A:

Fan Condition	Fan Speed	Fan Redundancy	Shutdown
System installed with 2 fan trays			
4 fans functioning normally	According to ambient and component temperature	N+1	Component hits thermal limit
1 fan fault	Remaining fans will spin at Max speed	Not supported	Component hits thermal limit
More than 1 fan fault	Remaining fans will spin at Max speed	Not supported	Upon detection, system will be shut down in 3 minutes or component hits thermal limit
System installed with 1 fan tray			

Fan Condition	Fan Speed	Fan Redundancy	Shutdown
2 fans functioning normally	According to ambient and component temperature	Not supported	Component hits thermal limit
1 fan fault	Remaining fans will spin at Max speed	Not supported	Upon detection, system will be shut down in 3 minutes or component hits thermal limit
2 fans fault	N/A	Not supported	Upon detection, system will be shut down in 3 minutes or component hits thermal limit
System with no fan tray			
Missing both fan tray/all fans faulted	N/A	Not supported	Upon detection, system will be shut down in 3 minutes or component hits thermal limit.



Fan redundancy refers to fans and not fan trays. With 2 fan trays installed, it allows 1 fan fault. With 1 fan tray, there is no fan redundancy.

Fan tray with faulty fan/fans must be replaced with Aruba 6300M Fan Tray (JL669A).

For JL658A, JL659A, and JL762A:

Fan Condition	Fan Speed	Fan Redundancy	Shutdown
4 fans functioning normally	Accordingly to ambient and component temperature	N+1	Component hits thermal limit
1 fan fault	Remaining fans will spin with Max speed	Not supported	Component hits thermal limit
More than 1 fan fault	Remaining fans will spin with Max speed	Not supported	Upon detection, system will be shut down in 3 minutes or component hits thermal limit.
Missing any fan tray/all fans faulted	N/A	Not supported	Upon detection, system will be shut down in 3 minutes or component hits thermal limit.

Power supplies

The following power supplies can be installed in the 6300M switches:

- **Aruba X371 12VDC 250W 100-240VAC Power Supply (JL085A):** A 250 watt power supply for the non-PoE switches. This power supply does not provide any PoE power, and is keyed so that it will not fit into the power supply slots of Aruba PoE switches.
- **Aruba X371 12VDC 250W 100-240VAC Power-to-Port Power Supply (JL760A):** A 250 watt and back-to-front fan flow power supply for the non-PoE switches. This power supply does not provide any PoE power and is keyed so that it will not fit into the power supply slots of Aruba PoE switches.



JL760A is for use only in the JL762A switch. This is the only power supply available for the JL762A switch.

- **Aruba X372 54VDC 680W 100-240VAC Power Supply (JL086A):** A 680 watt power supply for applicable PoE switches. Offers up to 370 watts of PoE power, and is keyed so that it will not fit into the power supply slots of non-PoE Aruba switches.
- **Aruba X372 54VDC 1050W 110-240VAC Power Supply (JL087A):** A 1050 watt power supply for applicable PoE switches. Offers up to 740 watts of PoE power, and is keyed so that it will not fit into the power supply slots of non-PoE Aruba switches.
- **Aruba X372 54VDC 1600W 110-240VAC Power Supply (JL670A):** A 1600 watt (high-line only) power supply for applicable PoE switches. Offers up to 1440 watts of PoE power, and is keyed so that it will not fit into the power supply slots of non-PoE Aruba switches.
- **Aruba 6300M 1050W 36-72VDC PSU (JL758A):** A 1050 watt power supply used for 6300M PoE switches. Offers up to 740 watts of PoE power, and is keyed so that it will not fit into the power supply slots of non-PoE Aruba switches.
- **Aruba 6300M 250WA 36-72VDC PSU (JL757A):** A 250 watt power supply used for 6300M non-PoE switches. The power supply does not provide any PoE power, and is keyed so that it will not fit into the power supply slots of the Aruba PoE switches.

Supported DC power supply combinations:

- Use of a JL757A with another JL757A PS on the same 6300M non-PoE switch SKU is supported
 - Use of a JL758A with another JL758A PS on the same 6300M PoE switch SKU is supported
-

Mixing of different types of AC and DC power supplies on a 6300M switch is not supported except for the following combinations:

- JL757A is interoperable with the JL085A on the supported 6300M non-PoE SKUs.
 - JL758A is interoperable with the JL087A on the supported 6300M PoE SKUs.
-

For initial power supply installation, see the *Start Here* guide that pertains to your power supply unit.

Power connector

The 6300M switches do not have a power switch. They will power on when either one or both power supplies are connected to an active power source.

LEDs on the back of the switches

This section describes the LEDs on the back of the switch. When the back LED on the front of the unit is blinking a fault, the user can look at the back of the switch to find the corresponding blinking LED for the faulted fan or power supply. If a user installs a second power supply and did not turn on the power (PSU module status = OFF), the back LED will blink orange.

Figure 1 Example LEDs on the back of 6300M switch

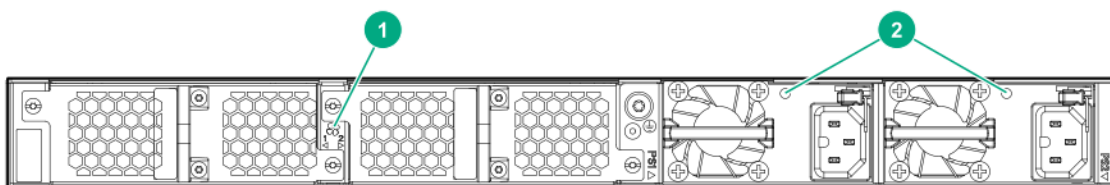

Table 8: Back of the 6300M switches LED labels and description

Label	Description
1	Fan tray LED
2	Power supply LED NOTE: On DC power supplies, these LEDs are located near the bottom of the power supply.

Figure 2 LEDs on the back of 6300F switch

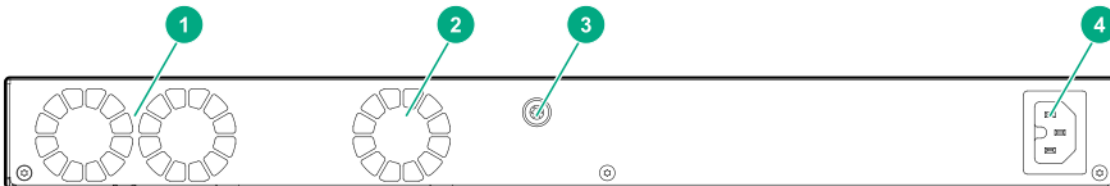

Table 9: Back of the 6300F switches LED labels and description

Label	Description
1	System fan
2	Integrated power supply fan
3	Ground lug (optional)
4	AC power inlet

Switch features

The features of the 6300F/M switches include:

- Combinations of fixed 10/100/1000-T, HPE Smart Rate, and SFP/SFP+/SFP56 ports.
- Selected switch models feature HPE Smart Rate ports and provide 1 Gbps, 2.5 Gbps, and 5 Gbps connectivity. See [Cabling specifications](#) for more information.
- JL762A features power-to-port (back-to-front) airflow, ideal for data center applications.
- Power over Ethernet (PoE) operation; enabled by default. The following switches power IP phones, wireless access points, indoor web cameras, and more.

Aruba 6300F/M switch	PoE per port	Standard
Aruba 6300M 48G Class 4 PoE and 4-port SFP56 Switch JL661A	Up to 30W	IEEE 802.3af/at
Aruba 6300M 24G Class 4 PoE and 4-port SFP56 Switch JL662A		
Aruba 6300F 48G Class 4 PoE and 4-port SFP56 Switch JL665A	Up to 30W	

Aruba 6300F/M switch	PoE per port	Standard
Aruba 6300F 24G Class 4 PoE and 4-port SFP56 Switch JL666A		
Aruba 6300M 48 HPE Smart Rate Class 6 PoE 100M/1G/2.5G/5G JL659A	Up to 60W	IEEE 802.3bt IEEE 802.3af/at**
Aruba 6300M 24 HPE Smart Rate Class 6 PoE 100M/1G/2.5G/5G JL660A		

*These switches also support some prestandard PoE devices.

**2-Pair Power non-compliant dual signature PDs up to class 4 power . Includes 2-Pair Power legacy 802.3 af/at with prestandard detect enabled.

For instructions on using the switch PoE features, see the *Monitoring Guide* for your switch.

- The option to have one or two modular power supplies in the switch:
 - A second power supply supports redundant system power and/or redundant/additional PoE power. If one of the modular power supplies fails, the second power supply immediately provides the power necessary to keep the switch running, including PoE power on an allocated basis.
 - If maximum PoE power is used on the 48-port PoE switches, the second power supply is needed for PoE power. There is no PoE power redundancy, but system power is always maintained. On a power supply failure, the system drops the PoE power on ports based on user priority, to maintain system power.
- Plug-and-play networking: All ports are enabled by default. Connect the network cables to active network devices and your switched network is operational.
- Auto MDI/MDI-X on all twisted-pair ports (10/100/1000), meaning that all connections can be made using straight-through twisted-pair cables. Cross-over cables are not required, although they will also work. The pin operation of each port is automatically adjusted for the attached device. If the switch detects that another switch or hub is connected to the port, it configures the port as MDI. If the switch detects that an end node device is connected to the port, it configures the port as MDI-X . (See the appendixes for recommended or required cabling.)
- Automatically negotiated full-duplex operation for the 10/100/1000 RJ-45 ports when connected to other auto-negotiating devices. The SFP+/SFP56 ports always operate at full duplex.
- Easy management of the switch through several available interfaces:
 - **Console interface:** A full-featured, easy-to-use, VT-100 terminal interface for out-of-band or in-band switch management.
 - **Web browser interface:** An easy-to-use built-in graphical interface that can be accessed from common web browsers.
 - **Bluetooth dongle and ArubaOS-CX Mobile App:** A convenient way to manage or configure your switch using your mobile device.
 - **Aruba AirWave:** A powerful and easy-to-use network operations system that manages wired and wireless infrastructures. For more information, visit <https://www.arubanetworks.com/products/networking/management/airwave>.
 - **Aruba Activate:** Cloud-based service that provides inventory control and facilitates Zero Touch Provisioning.

- **Aruba ClearPass Policy Manager:** Network policy management software for wired and wireless network devices that provide on-boarding and role-based control/security.
- **Aruba Central:** Network management software cloud platform. It offers IT organizations a simple, secure, and cost-effective way to manage and monitor Aruba switches and Aruba instant wireless APs.
- Support for the Spanning Tree Protocol to eliminate network loops.
- Support for up to 4095 IEEE 802.1Q-compliant VLANs so you can divide the attached end nodes into logical groupings that fit your business needs.
- Support for many advanced features to enhance network performance: For a description, see the AOS-CX guides for your switch.
- Ability to update the switch software. To download product updates, go to the [Aruba Support Portal](#).
- An auxiliary port (USB Type A connector) for updating switch software.
- Switch Hibernation mode to allow the switch to power down for a period each day to save energy.

The following sections shows how to install the switch. The switches come with an accessory kit that includes the brackets for mounting the switch in a standard 19-inch telco rack or in an equipment cabinet. Also included are rubber feet that can be attached so the switch can be securely positioned on a horizontal surface. The brackets are designed to allow mounting the switch in a variety of locations and orientations. For other mounting options, contact your local Hewlett Packard Enterprise authorized network reseller or Hewlett Packard Enterprise representative.

Shipping the switch in a rack

If the switch is to be shipped in a rack, it can be mounted and shipped in a Hewlett Packard Enterprise Universal Rack.

- This method uses the HPE X410 Universal Rack Mounting Kit (J9583A).
- To order the J9583A rack mounting kit, contact your Aruba sales representative.

Included parts

The 6300M switches have the following components shipped with them:



A USB-C to USB-A console cable can be ordered separately, or as an accessory to your switch. JL482A - X472 2-Post Rack Kit can be ordered separately, or as an accessory to your switch.

- Documentation kit
- Bluetooth Dongle (5400-3372): Mounting on USB type-A AUX for rapid configuration and deployment
- Accessory kit (5300-0103) containing:
 - two mounting brackets
 - eight 8-mm M4 screws to attach the mounting brackets to the switch
 - four 5/8-inch number 12-24 screws to attach the switch to a rack
 - four rubber feet
- Power cord, one of the following (included with power supply unit):

Aruba 6300M PoE Switches (with AC power supplies)			
North America	8121-0973	Australia	8121-0857
North America high line	8121-0941	Brazil	8121-1265
South Africa/India	8121-1483	Europe/South Korea	8120-5336
Israel	8121-1009	China	8121-1034

Aruba 6300M PoE Switches (with AC power supplies)			
United Kingdom/Hong Kong/Singapore/Malaysia	8120-5334	Argentina	8121-1481
Switzerland	8120-5339	Chile	8120-8389
Danish	8120-5340	Thailand/Philippines	8121-0671
Japan high line	8120-5338 (JL086A, JL087A)	Taiwan 15A	8121-1511 (JL086A, JL087A)
Japan low line	8120-5342 (JL086A)	Taiwan 10A	8121-0967 (JL086A)

Aruba 6300M Non-PoE Switches (with AC power supplies)			
Argentina	8120-6869	Japan	8120-4753
Australia/New Zealand	8121-0834	Switzerland	8120-6815
Brazil	8121-1069	South Africa	8120-6813
Chile	8120-6980	Taiwan	8121-0974
China	8120-8707	Philippines/Thailand	8121-0668
Continental Europe/South Korea	8120-6811	UK/Hong Kong/Singapore/Malaysia	8120-6809
Denmark	8120-6814	US/Canada/Mexico	8121-0973
India	8121-0780	North America high line	8121-0941
Israel	8121-1035		

Aruba 6300M PoE Switches (with DC power supplies)	
Worldwide	5400-3519

Aruba 6300M non-PoE Switches (with DC power supplies)	
Worldwide	5400-3521

製品には、同梱された電源コードをお使い下さい。
同梱された電源コードは、他の製品では使用出来ません。

Installation procedures for 6300 switches

1. Prepare the installation site.
2. Unpack the switch and verify that you have received the correct parts.
3. If installing a modular switch, install a power supply if the switch was not shipped with a power supply already installed.

4. Connect power to the switch and wait for the health LED to turn green after the switch passes the self-test, then remove power from the switch.
5. Mount the switch.



Mounting restrictions apply. See the "Warning" under "Installation precautions and guidelines".

6. Connect the switch to a power source.
7. (Optional) Install transceivers.
8. Connect the network cables.
9. Configure the switch for network operation.

Installation precautions and guidelines

To avoid personal injury or product damage when installing your switch, read the following installation precautions and guidelines.

-
- Do not mount the switch on a wall or under a table or under another horizontal surface.
 - Mount devices installed in a rack or cabinet as low as possible. Put the heaviest devices at the bottom and progressively lighter devices positioned higher.
 - To prevent the rack or cabinet from becoming unstable and/or falling over, ensure that it is adequately secured.
 - When powered by a DC power supply, the switch must be installed in a restricted access location. Only trained and qualified personnel should be allowed to install, replace, or service this equipment.
 - For switches with DC power supplies: Disconnect DC power from the power supply BEFORE installing or removing the power supply. The power supply must NOT be connected to DC power while it is being installed or removed. The switch power supplies are hot-swappable; that is, a power supply that is disconnected from the power source can be installed or removed while the switch is receiving power from another power supply installed in the other power supply slot.
 - Always switch input power OFF before connecting and disconnecting the DC input to the unit. If not turned off, there is a risk of injury or severe damage.
 - When powered by a DC power supply, the product relies upon the installation to provide short-circuit (overcurrent) protection. Ensure that the protective device is not greater than 20A for non-PoE switches and not greater than 40A for PoE switches when using DC power.
 - When powered by a DC power supply, the installation shall provide a readily accessible two-pole disconnect device in the fixed installation.
-



-
- If your installation requires a different power cord than the one supplied with the switch and power supply, be sure that the cord is adequately sized for the current switch requirements. In addition, be sure to use a power cord displaying the mark of the safety agency that defines the regulations for power cords in your country/region. The mark is your assurance that the power cord can be used safely with the switch and power supply.
 - Do not ship any switch in a rack without checking for restrictions. Otherwise, you may void the switch warranty.
 - Ensure that the power source circuits are properly grounded. Then connect the switch to the power source by using the power cord supplied with the switch.
 - When installing the switch, ensure that the AC outlet is near the switch. Make it easily accessible in case the switch must be powered off.
 - Ensure that the power cord and network cables at the switch mounting location do not create a tripping hazard.
 - Do not install the switch in an environment where the operating ambient temperature exceeds its specification. For operating temperature information, see [Physical and environmental](#) specifications.
 - Ensure that the switch does not overload the power circuits, wiring, and over-current protection at your installation site. To determine the possibility of overloading the supply circuits, add the ampere ratings of all devices installed on the same circuit as the switch. Then compare the total with the rating limit for the circuit. The maximum ampere ratings are printed on the devices near the AC power connectors.
 - Avoid blocking any ventilation openings on the sides, rear, or front of the switch.
 - Ensure that the air flow around the switch is not restricted. Leave at least 3 inches (7.6 cm) for cooling.
 - A slot cover plate **MUST** be secured over any power supply slot that does not contain a power supply unit. This is required for proper air flow and thermal operation. Leaving a power supply slot uncovered can cause an over-temperature condition inside the switch that can result in the switch shutting down. During replacement of a power supply unit, it is acceptable to allow the slot to remain uncovered for up to two minutes in a switch connected to a power source.
-

◇ If a power supply must be removed, and then reinstalled, wait at least 5 seconds before reinstallation. Otherwise, damage to the switch may occur. The power supply needs this time to bleed off any retained power. Install a cover plate on any slot in the switch that is not in use.

Prepare the installation site

Cabling Infrastructure: Ensure the cabling infrastructure meets the necessary network specifications. See [Cabling and technology information](#) for more information.

Installation Location: Before installing the switch, plan its location and orientation relative to other devices and equipment:

- In the front or the back of the switch, leave at least 7.6 cm (3 inches) of space for the twisted-pair and fiber-optic cabling.
- In the back of the switch, leave at least 7.6 cm (3 inches) of space for the power cord.
- On the sides of the switch, leave at least 7.6 cm (3 inches) for cooling, except if the switch is installed in an open EIA/TIA rack.

Figure 1 *Air Flow Direction of the 6300 Switches (except JL762A)*

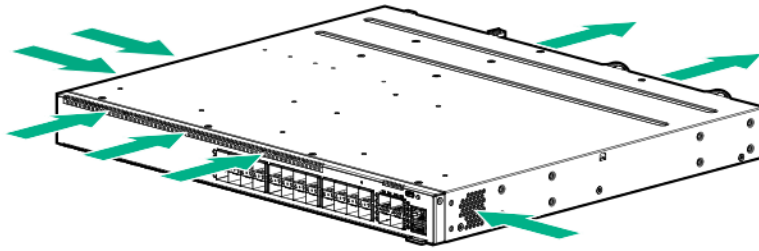
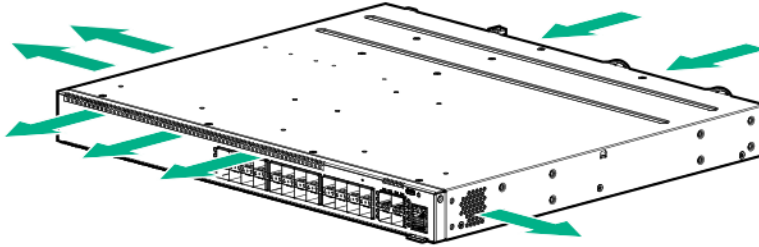
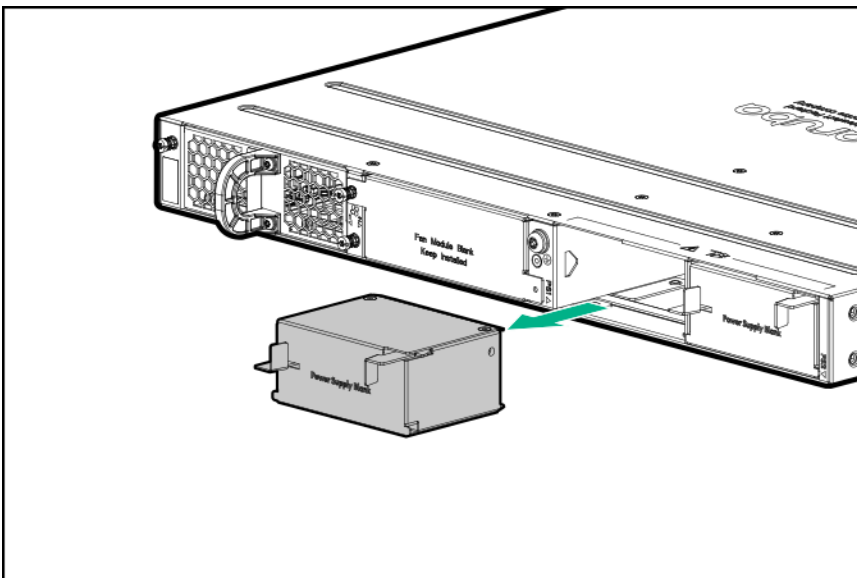

Figure 2 Air flow Direction of the JL762A Switch



Install a power supply or a second power supply for modular switches

1. Remove the power supply blank.



2. Insert the power supply.

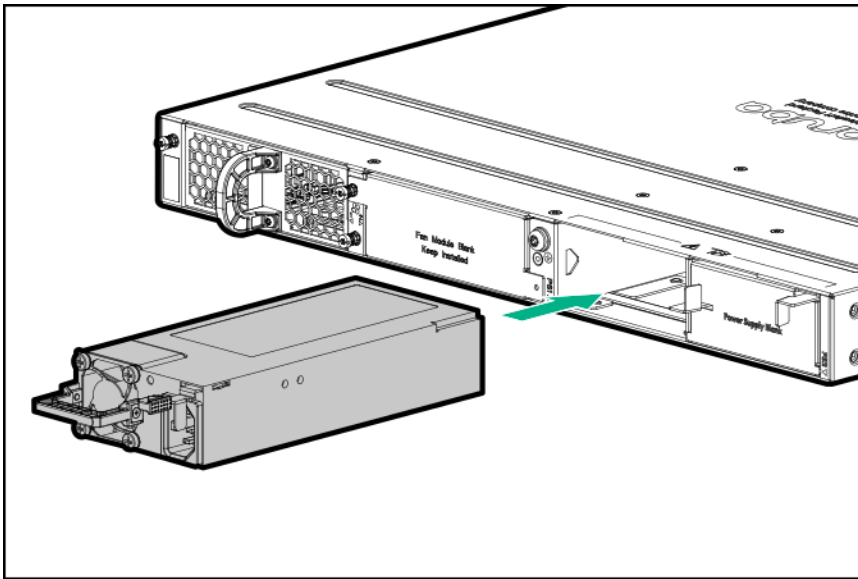

3. Place the unit inside the rack, making sure the PSU is properly and fully inserted into the switch with the latch locked into place.

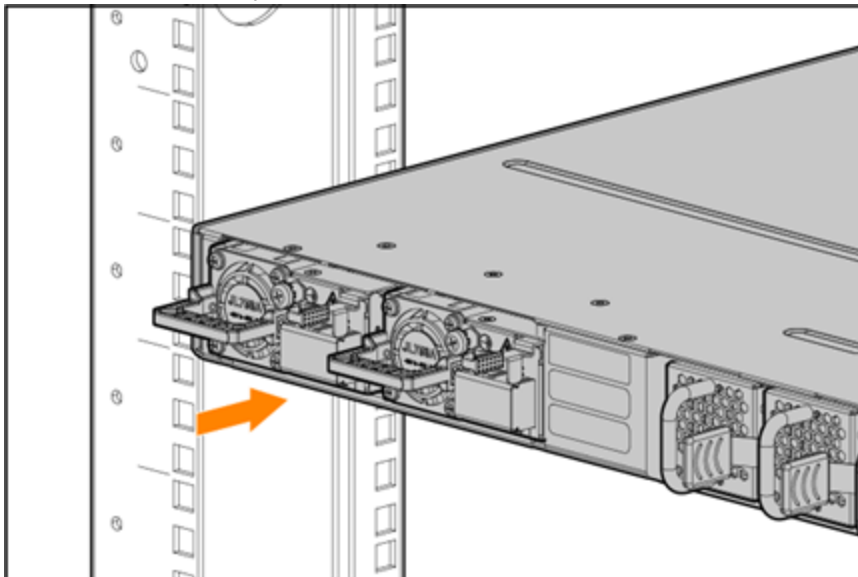

AC power supply

1. Use the supplied AC cable for the power supply and the 6300M switch being installed.
2. Insert the 3-way modular connector of the AC cable into the inlet on the power supply. Ensure that the connectors are firmly mated.
3. Connect the other end of the AC cable to a nearby AC power source.

DC power supply



When using a DC power supply, the unit should be installed in a restricted access location. Only trained and qualified personnel should be allowed to install, replace, or service this equipment.



Ensure that the DC cable is disconnected from the DC power source before proceeding with the installation.

1. Ensure that the correct DC cable is used for the power supply being installed.
 - a. Included DC cable HPPN 5400-3519 for JL758A (8AWG cable with Ring lugs).
 - b. Included DC cable HPPN 5400-3521 for JL757A (12AWG cable with Ring lugs).
2. Organize and tie the cable. The DC cable needs to be strain-relieved by tying securely it to a fixed structure or rack. **NOTE:** Do not tie the DC cables to the power supply fan handle as it is not designed to take the weight of the cables.

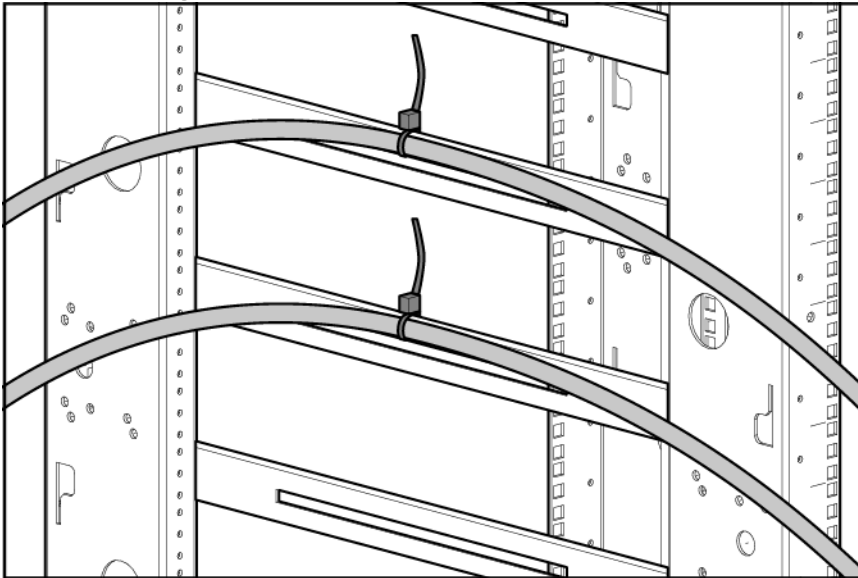

Ensure that the DC cable does not obstruct or block the air flow of the power supply fan.

3. Remove the transparent protective cover from the DC input connector of the power supply and set it aside.

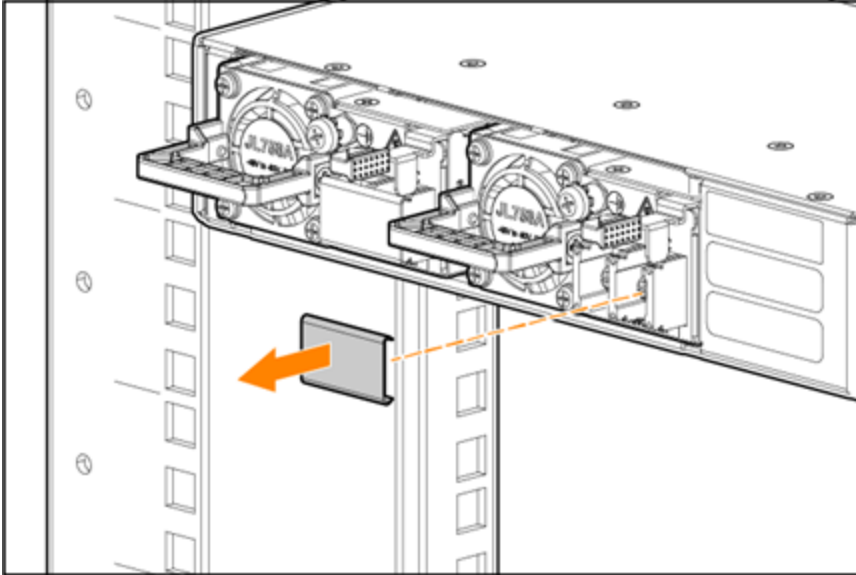

4. Install the Ground, +DC, and -DC wires, making sure there is a three-inch gap (1 in below illustration) below the unit for the DC cable. Fasten the Green wire to the Screw Terminal marked with \oplus on the power supply.



Do not install the cable lugs in the reverse direction. When correctly installed, the crimped and protruded portion of the insulator on the cable lugs should be facing outwards.

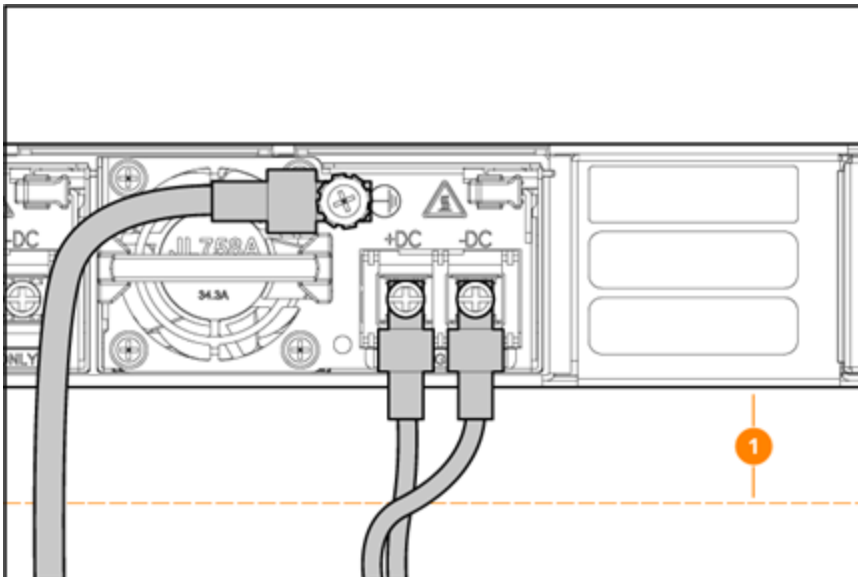

5. Make sure that all the screw terminals are tightened. Under no circumstances should any screw terminals be loose.

6. Reinstall the transparent protective cover on the DC input connector of the power supply.

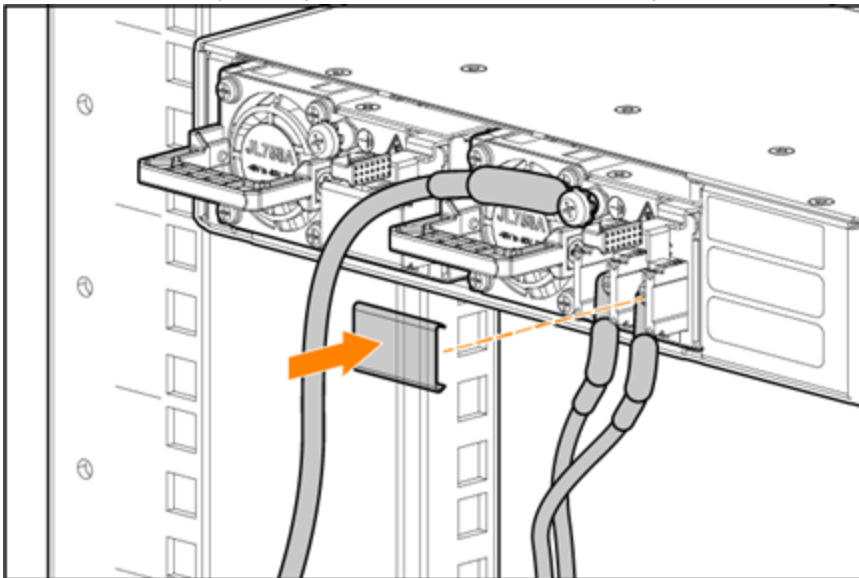

7. Connect the other end of the DC cable to a DC source following the correct polarity.



Do not move the unit with the power supply after the DC cables are installed.

Do not remove the DC power supply from the unit with the DC cable installed or the DC source turned on.

Grounding is required for DC power supplies and systems.



The DC power inlet in the power supply has two terminals labeled +DC and -DC and has a screw marked with



symbol to connect to earth ground. The DC power inlet has a clear plastic cover.

Unplugging the DC PSU from the system when the PSU is powered is not supported. The DC input power source has to power off before removing the DC PSU from the system.

Verify the switch boots correctly

Before installing the switch in its network location, plug it into a power source and verify that it boots correctly.

Procedure

1. Connect the power cord supplied with the switch to the power connector on the back of the switch. Then plug the power cord into a properly grounded electrical outlet.



The switches do not have a power switch. They are powered on when the power cord is connected to the switch and to a power source. For safety, locate the power outlet near the switch installation.

If your installation requires a different power cord than the one supplied with the switch, be sure to use a power cord displaying the mark of the safety agency that defines the regulations for power cords in your country/region. The mark is your assurance that the power cord can be used safely with the switch.

2. Check the LEDs on the switch to make sure the switch is on and operating.

When the switch is powered on, it performs its diagnostic self-test and initialization. This boot process, depending on switch model and configuration, takes approximately 1-2 minutes to complete.

Disconnect power from the switch

Disconnect the power cord from all of the switch power supplies and from the power sources.

Mount the switch

After the switch passes self-test, it is ready to be mounted in a stable location. Supported mounting options for the Aruba 6300M switches include:

- Two-post rack mount
- Tabletop or desktop
- Four-post rack mount (Requires the optional J9583A HPE X410 Universal Rack Mounting Kit.)



Do not mount the switch on a wall, under a table, or under another horizontal surface.

Mounting a switch on a tabletop or desktop

Before you begin:

- Locate the four self-adhesive pads included in the switch accessory kit.
- Select a secure horizontal surface where the network cables and switch power cord will not create a tripping hazard.

To mount the switch to a tabletop or desktop:

1. Attach the four self-adhesive pads to the bottom corners of the switch.

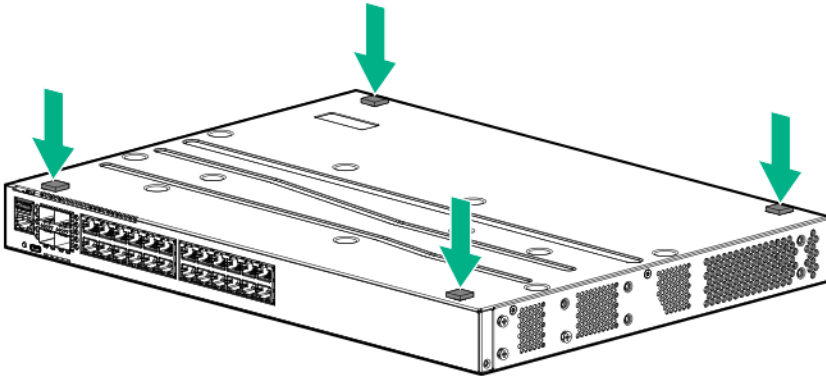

2. Position the switch with the top panel up on the selected horizontal surface.

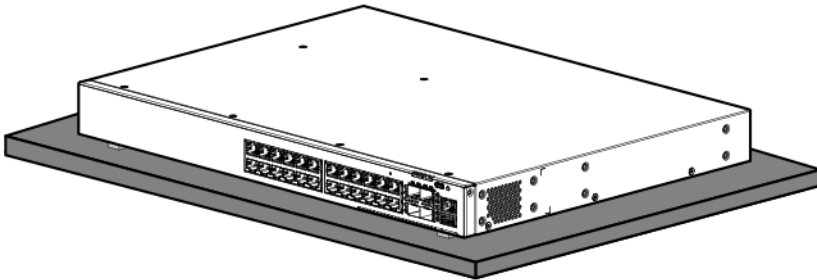

Ensure that the power cord and network cables at switch mounting location will not create a tripping hazard.



Avoid blocking any ventilation openings on the sides, rear, or front of the switch.

Mounting the switch in a two-post rack

Before you begin, prepare your network data cables (not included) for connecting the switch to the network.

To mount the switch in a two-post rack:

1. Attach the rack mount brackets to the switch by using a #1 Phillips (cross-head) screwdriver and the supplied eight 8-mm M4 screws.

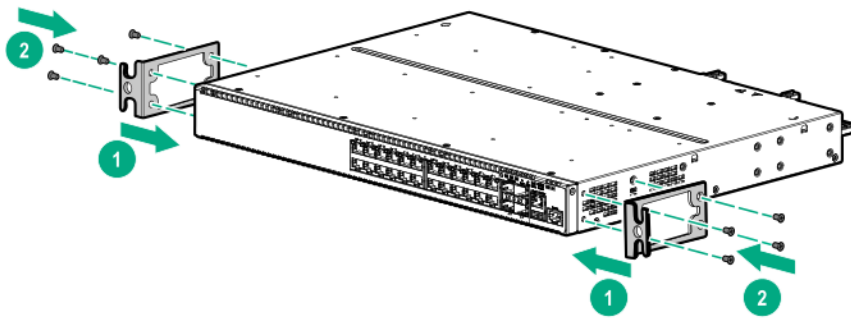

2. Use the four number 12-24 screws to secure the brackets to the rack.

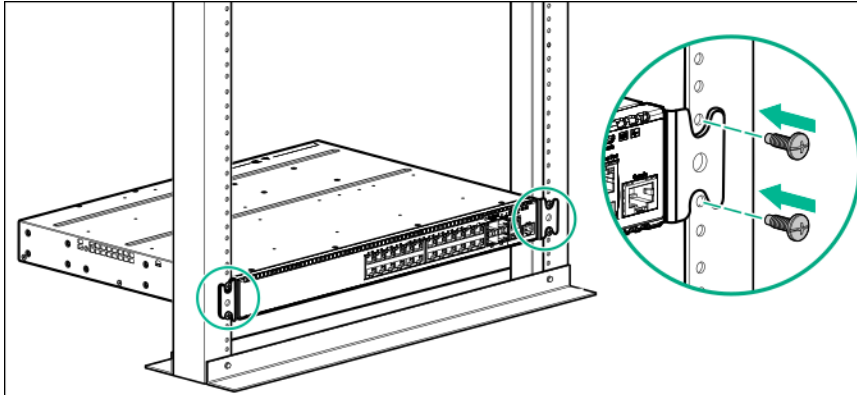

Mounting the switch in a four-post rack

The four-post rack mount for the switches requires the optional J9583A HPE X410 Universal Rack Mounting Kit. To use this kit to mount a switch, see the installation instructions provided with the kit.

Connect the switch to a power source

For AC power supplies: Plug the included power cord into the power connector on the switch and into a nearby AC power source.

For DC power supplies: Use the supplied DC power cable with the DC power supply. Follow the instructions in [Install a power supply or a second power supply for modular switches](#) to connect and install the DC cable to the power supply and DC power source.

When powered by a DC power supply, the product relies upon the installation to provide short-circuit (overcurrent) protection. Ensure that the protective device is not greater than 20A for non-PoE switches and not greater than 40A for PoE switches when using DC power.

Make sure the power source is properly grounded before connecting power to the power supply.

Warning: A readily accessible two-pole disconnect device must be provided in the fixed installation.

Recheck the LEDs during self-test.

Install transceivers (optional)

You can install or remove transceivers from the slots on the front of the switch without having to power off the switch.



- The transceivers operate only at full duplex. Half duplex operation is not supported.
- Ensure that the network cable is NOT connected when you install or remove a transceiver.
- 24 SFP+ switches can support up to 48 transceivers.

(Optional) Insert up to four SFP transceivers in the fixed transceiver slots on the switch front panel.

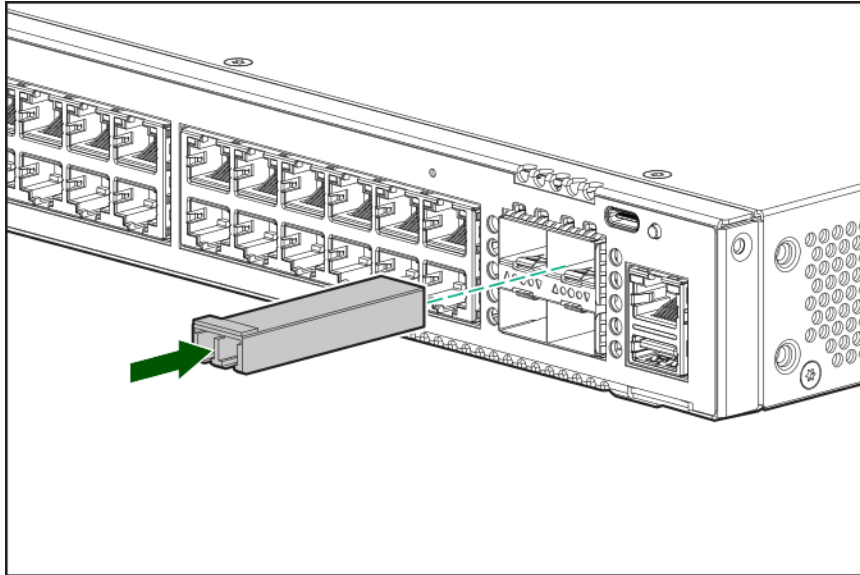

Connect network cables

Connect network cables from network devices or your patch panels to the fixed RJ-45 ports and to any installed transceivers.

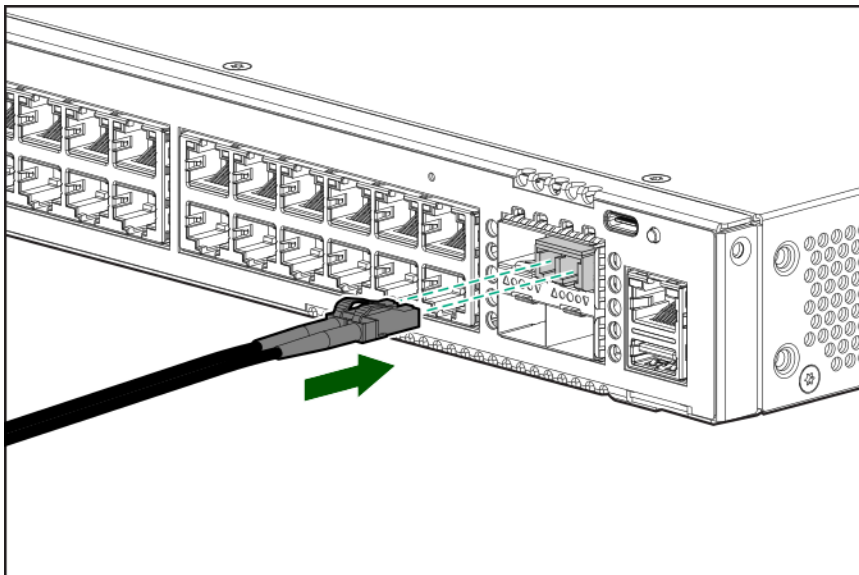

Connect network cables to the RJ-45 data ports and to any optional transceivers installed on the switch front panel.

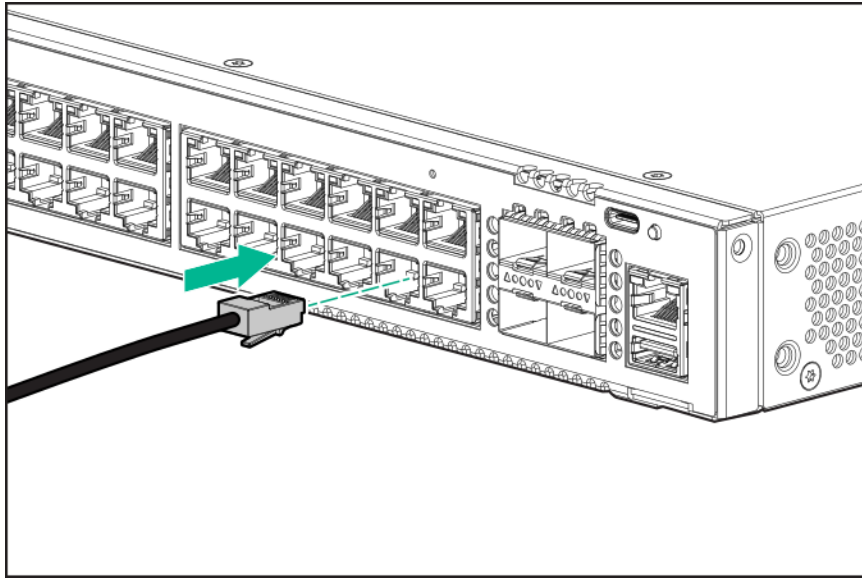

SFP/SFP+/SFP28/SFP56 installation notes



When selecting a fiber SFP/SFP+/SFP28/SFP56 device, make sure it can function at a maximum temperature that is not less than the recommended maximum operational temperature of the product. Use only an approved Laser Class 1 SFP/SFP+/SFP28/SFP56 transceiver.

To ensure proper operation of your switch, use only the HPE Aruba SFP/SFP+/SFP28/SFP56 transceivers supported by your switch.

Use only supported Aruba SFP/SFP+/SFP28/SFP56 transceivers

Non-Aruba SFP/SFP+/SFP28/SFP56 transceivers are not supported. Use of supported Aruba products ensures that your network maintains optimal performance and reliability. If you require additional transceivers, contact an Aruba sales representative or an authorized reseller. The following resources can help you to find transceiver support information for your switch model:

- See the *Transceiver Guide*.
- See the supported transceivers information in the Data Sheet for your switch model.

Hot swapping SFP/SFP+/SFP28/SFP56 transceivers

Supported SFP/SFP+/SFP28/SFP56 transceivers that you can install in your Aruba switch can be “hot swapped”—removed and installed while the switch is receiving power. However, disconnect the network cables from the SFP/SFP+/SFP28/SFP56 transceivers before hot-swapping them.

When you replace a SFP/SFP+/SFP28/SFP56 transceiver with another transceiver of a different type, the switch may retain selected port-specific configuration settings that were configured for the replaced unit. Be sure to validate or reconfigure port settings as required.

SFP/SFP+/SFP28/SFP56 connections to devices with fixed speed/duplex configurations

When connecting a device to your switch port that contains a SFP/SFP+/SFP28/SFP56 transceiver, the speed and duplex settings of the switch port and the connected device must match. Otherwise, the device may not link properly—you may not get a link. For some older network devices, the default speed/duplex settings may be predefined such that they are set differently from the default configuration of your switch. (For example, 1000 Mbps/Full Duplex.) These setting differences may also apply to some older Hewlett Packard Enterprise devices. Because of these default speed/duplex considerations, make sure that devices

connected to your SFP/SFP+/SFP28/SFP56 ports are properly configured. At a minimum, make sure the configurations match.

Sample network topologies

This section shows a few sample network topologies in which the switch is implemented.

The switch is designed to be used primarily as a desktop switch. End nodes, printers and other peripherals, and servers are directly connected, as shown in the following illustration. Notice that the end node devices are connected to the switch by straight-through or crossover twisted-pair cables. Either cable type can be used because of the IEEE Auto MDI/MDI-X features on the switch.

Figure 1 Example as a Desktop Switch Implementing PoE

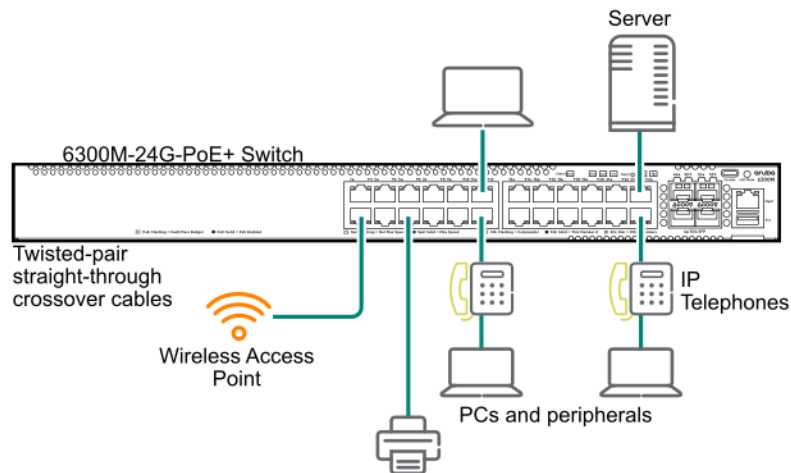

This illustration is an example of the switch being configured to supply PoE power to end devices such as IP telephones and wireless access points (WAPs).

As shown in this figure, the IP telephones can be connected in line, that is, between the switch and the end device, in this case a PC. The IP telephones in this illustration have two ports, one in and one out. Therefore the phone receives voice data and power from the switch, and the PC can send and receive data through the phone to the switch.

The end node devices are connected to the switch by straight-through or crossover twisted-pair cables. Either cable type can be used because of the IEEE Auto MDI/MDI-X features on the switch.

Figure 2 Example as a Segment Switch

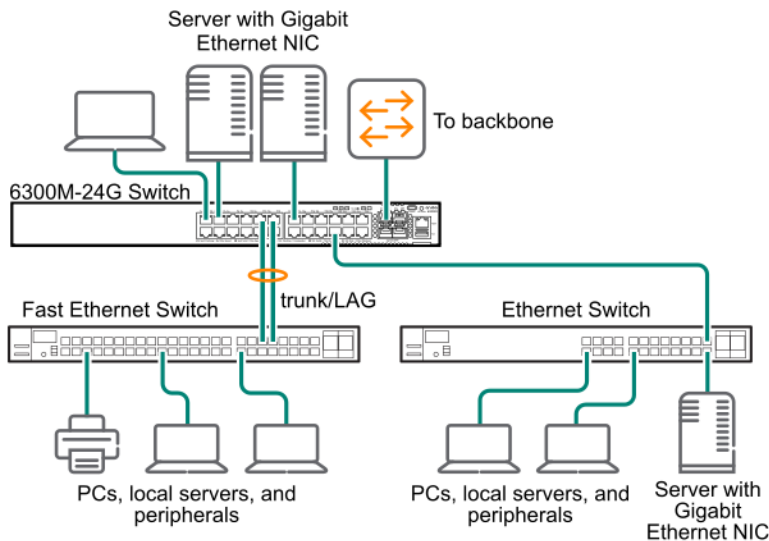

The switch also works well as a segment switch. That is, with its high performance, it can be used for interconnecting network segments. Simply connect the network hubs that form those segments to the switch or you can also connect other switches.

In the preceding illustration, two fast Ethernet hubs with PCs, printers, and local servers attached, are both connected to a switch. The devices attached to the two hubs can now communicate with each other through the switch. They can also all communicate with the server that is connected to a 1000Base-T port on the switch.

Because the switch has the IEEE Auto MDI/MDI-X features, the connections between the switch and the hubs, and between the switch and end nodes or servers, can be through category 5 straight-through or crossover twisted-pair cable.



SmartRate speeds 2.5G/5G requires Category 5e cable.

If the connection is 10 Mbps only, then category 3 or 4 cable can also be used. In all cases, the device ports must be configured to auto negotiate the link characteristics for this feature to work.

The switch, in turn, can be connected to a network backbone through fiber-optic cabling connected to a Gigabit-SX, -LX, or -LH transceiver installed in the switch. Now, all the devices on these network segments can access other network resources that are connected elsewhere on the network backbone.

Figure 3 Example as a Segment Switch Implementing PoE

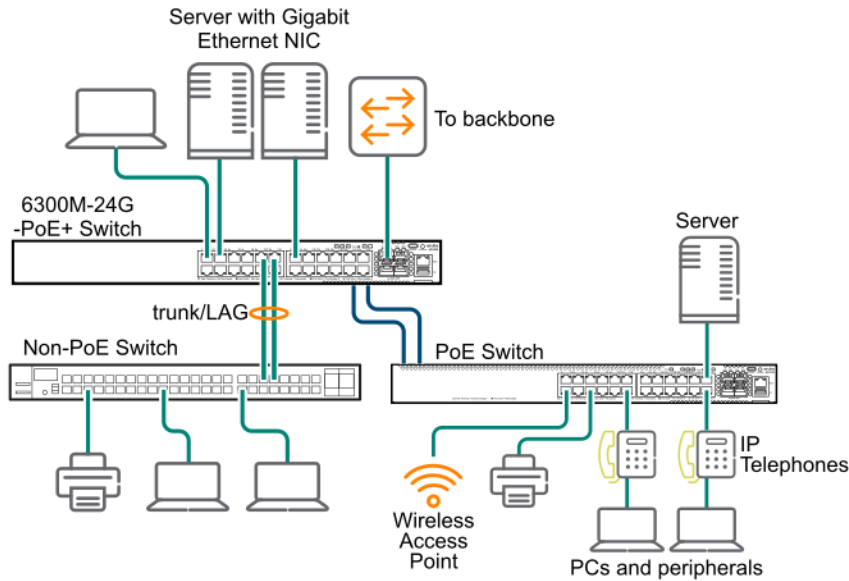
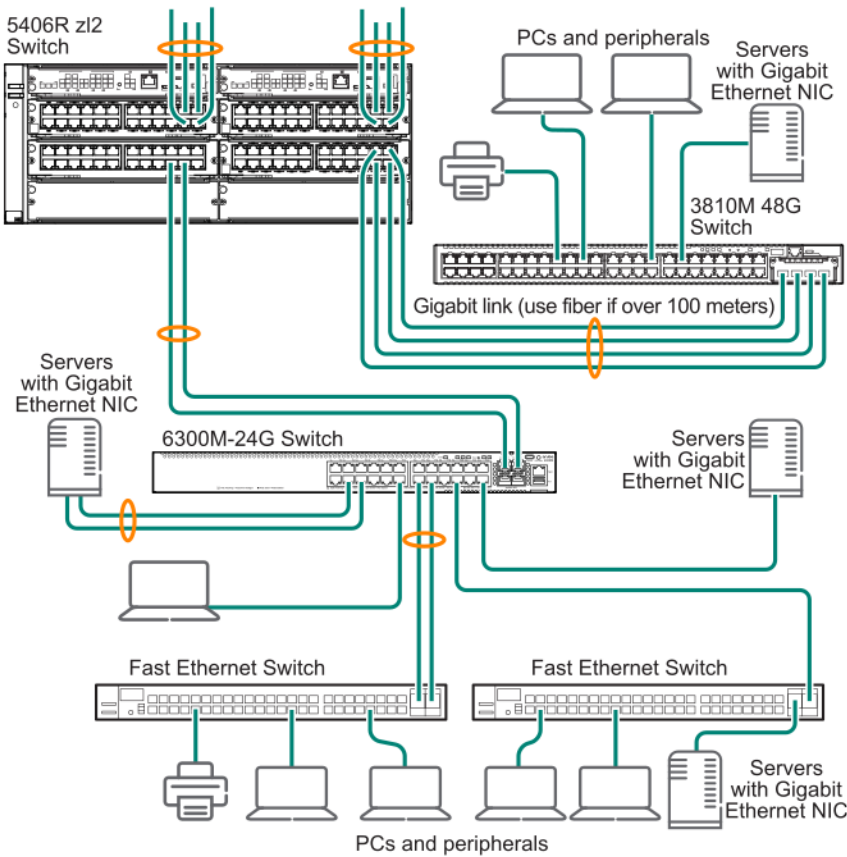

Figure 4 Example of Connecting to a Backbone Switch



For example, you can use an backbone switch to interconnect each of your smaller work group switches to form a larger network. All devices in this network can communicate with each other and also with the campus backbone. Depending on your bandwidth needs, the links between switches can run at 1G/10G/25G/50G, and use copper or fiber cabling with the appropriate SFP/SFP+/SFP28/SFP56 transceivers. Links can also be aggregated for additional bandwidth and redundancy.

This chapter is a guide for using the console Switch Setup screen to quickly assign an IP address and subnet mask to the switch. You can also set a Manager password and, optionally, configure other basic features. For more information on using the switch console, see the *Fundamentals Guide* for your switch model.

Recommended minimal configuration

In the factory default configuration, the switch has no IP address and subnet mask, and no passwords. In this state, it can be managed only through a direct console connection. To manage the switch through in-band (networked) access, configure the switch with an IP address and subnet mask compatible with your network. See the *Fundamentals Guide* for your switch for more information on the various methods that can be used for initial configuration.

Also, configure a Manager password to control access privileges from the console and web browser interface. Other parameters in the Switch Setup screen can be left at either their default settings or settings you manually enter.

Many other features can be configured through the switch console interface to optimize performance, to enhance your control of the network traffic, and to improve network security. Once an IP address has been configured on the switch, these features can be accessed more conveniently through a remote Telnet session, through the switch web browser interface, and from an SNMP network management station running a network management program. For a list of switch features available with and without an IP address, see the latest version of the *Fundamentals Guide* for your switch.

Setup for initial configuration

For initial configuration information, see the *Fundamentals Guide* for your switch.

This chapter describes how to remove and install the following components in the Aruba 6300M Switch Series:

- Power supply
- Fan tray



There are no user-replaceable parts on the Aruba 6300F Switch Series.



The 6300M switches and their components are sensitive to static discharge. Use an antistatic wrist strap and observe all static precautions when replacing components.

If a power supply must be removed, and then reinstalled, wait at least 5 seconds before re-installation. Otherwise, damage to the switch may occur. The power supply needs this time to bleed off any retained power.

Replacing the fan

If a fan has failed, the fan LED will flash simultaneously with the switch Fault LED. Replace the failed component as soon as possible.



JL762A (Aruba 6300M 48G Pwr2Prt 2F 1PS Bdl) has power-to-port (back-to-front) airflow and requires two JL761A (Aruba 6300M Power-to-Port Fan Tray). Other 6300M fan trays are not supported in the JL762A switch. All other 6300 switches have port-to-power (front-to-back) airflow; JL761A fan trays are not supported in any other 6300M switch other than the JL762A.

To Remove an Existing Fan:

1. Loosen the T10 screws by turning counter clockwise.
2. Grasping the pull handle of the failed fan, remove the component.

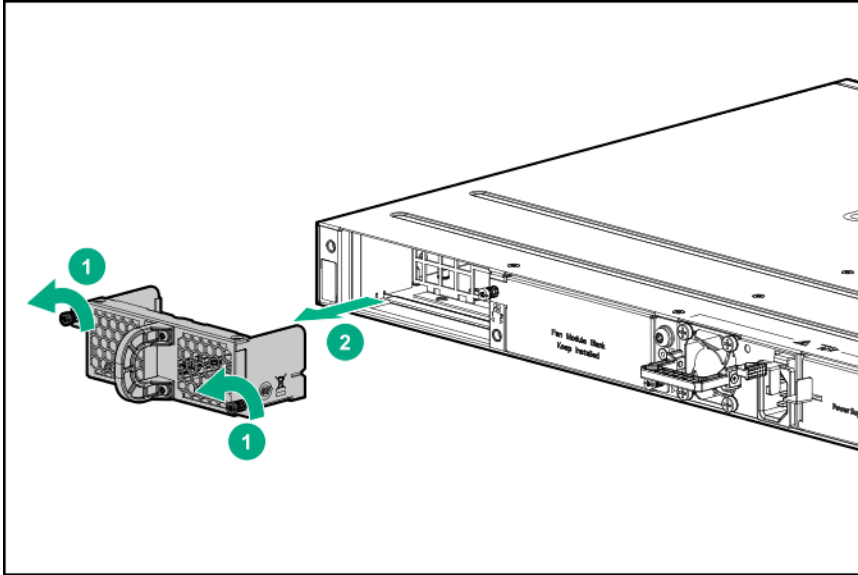

3. Insert the new fan by sliding the component all the way.
4. Tighten the T10 screws by turning them clockwise.

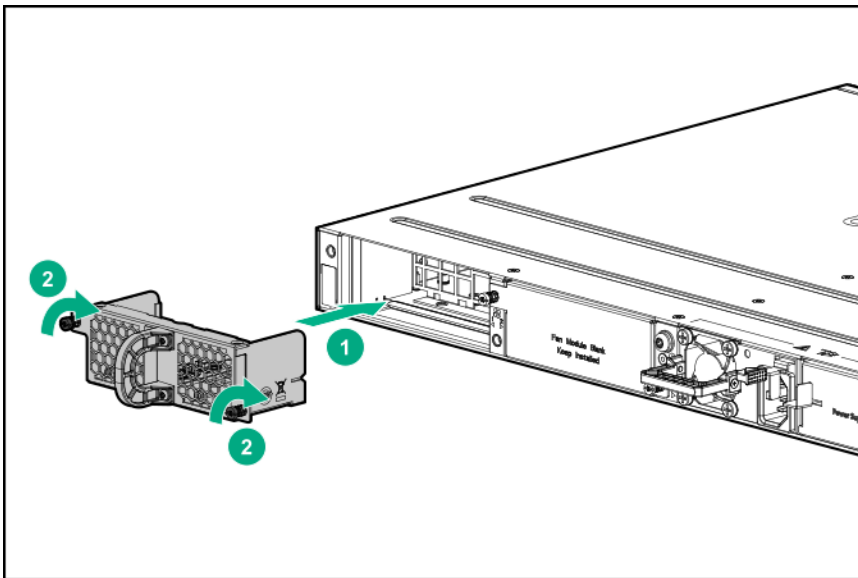

Replacing the power supply

If the switch is configured with redundant power supplies, the switch will not suffer any loss of traffic or performance if one power supply fails. Replace the failed component as soon as possible. The PS (Power Supply) LED will flash simultaneously with the switch Fault LED indicating a power supply has failed.



JL762A (Aruba 6300M 48G Pwr2Prt 2F 1PS Bdl) has power-to-port (back-to-front) airflow and requires JL760A (Aruba X371 12VDC 250W 100-240VAC Power-to-Port Power Supply). Other 6300M power supplies are not supported in the JL762A switch. All other 6300 switches have port-to-power (front-to-back) airflow; JL760A power supply is not supported in any other 6300M switch other than the JL762A.



Unplugging the DC power supply when the PSU is powered on is not supported.

AC power supply

1. Remove the AC power cable from the connector on the failed power supply.
2. Grasping the handle of the failed power supply, release the locking mechanism by squeezing the latch handle while removing the failed power supply.

Figure 1 Replacing a Failed Power Supply

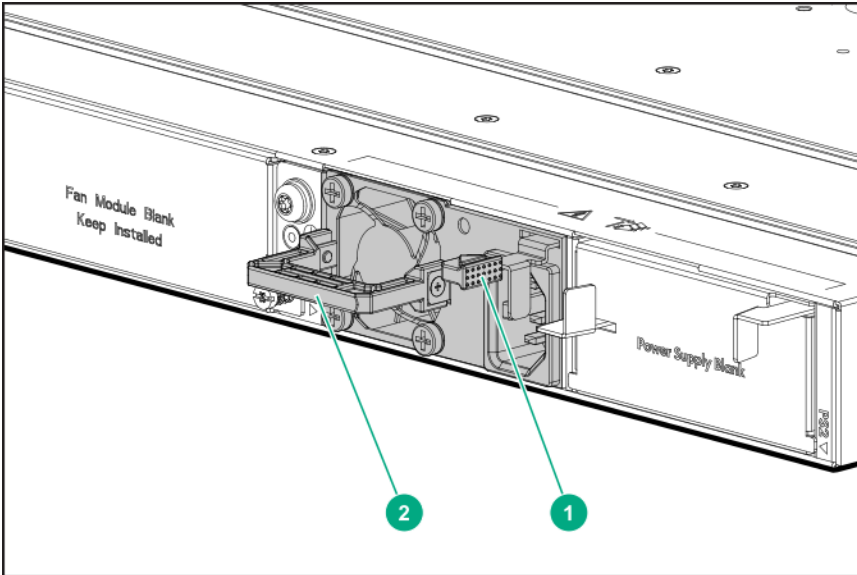
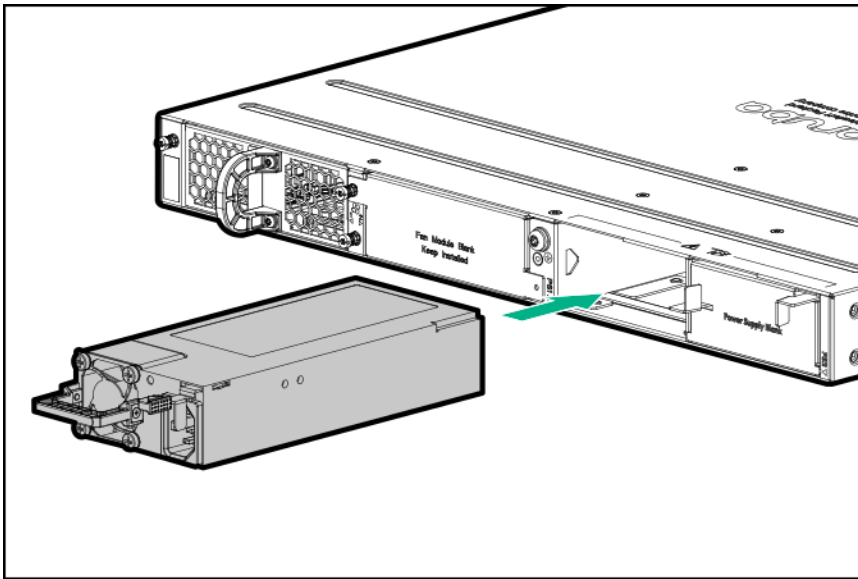

Table 10: Replacing Failed Power Supply: Label and Description

Label	Description
1	Lock mechanism
2	Handle

3. Insert the new power supply. Slide it in all the way in until the locking mechanism locks.



DC power supply

1. Switch off the DC source and remove the DC cable from the DC source.
2. Remove the transparent protective cover from the DC input connector on the DC power supply. Unfasten the DC cable from the DC power supply. Remember to reinstall the protective transparent cover back on the DC power supply input connector.
3. Grasping the handle of the failed power supply, release the locking mechanism by squeezing the latch handle while removing the failed power supply.
4. Insert the new power supply. Slide it in all the way in until the locking mechanism locks.
5. Follow the steps to install the DC cable on the DC power supply found in [Install a power supply or a second power supply for modular switches](#).
6. Connect the DC cable to the DC source.

This chapter describes how to troubleshoot your switch, primarily from a hardware perspective. You can perform more in-depth troubleshooting on the switch using the software tools available with the switch. Included are the console interface and the built-in web browser interface.

Basic troubleshooting tips

Most problems are caused by the following situations. Check for these items first when starting your troubleshooting:

- **Connecting to Devices that have a Fixed Full-Duplex Configuration:** The RJ-45 ports are configured as “Auto”. That is, when connecting to attached devices, the switch operates in either half duplex or full duplex to determine the link speed and the communication mode:
 - If the connected device is also configured to Auto, the switch will automatically negotiate both link speed and communication mode.
 - If the connected device has a fixed configuration, for example 100 Mbps, at half or full duplex, the switch will automatically sense the link speed, but will default to a communication mode of half duplex.

Because the switch behaves in this way (in compliance with the IEEE 802.3 standard), if a device connected to the switch has a fixed configuration at full duplex, the device will not connect correctly to the switch. The result will be high error rates and inefficient communications between the switch and the device.

Make sure that all the devices connected to the switch are configured to auto negotiate, or are configured to speed and duplex settings matching the settings configured on the corresponding switch port.

- **Improper Network Topologies:** It is important to make sure that you have a valid network topology. Common topology faults include excessive cable length and excessive repeater delays between end nodes. If you have network problems after recent changes to the network, change back to the previous topology. If you no longer experience the problems, the new topology is probably at fault. Sample topologies are shown at the end of chapter 2 in this book.

In addition, make sure that your network topology contains no data path loops. Between any two end nodes, only one active cabling path is allowed at any time. Data path loops can cause broadcast storms that will severely impact your network performance.

For your switch, if you want to build redundant paths between important nodes in your network to provide some fault tolerance, enable Spanning Tree Protocol support on the switch. This support ensures that only one of the redundant paths is active at any time, thus avoiding data path loops. For more information on Spanning Tree, see the Layer 2 Bridging Guide.

- **Faulty or Loose Cables:** Look for loose or faulty connections. If they appear to be OK, make sure that the connections are snug. If that does not correct the problem, try a different cable.
- **Nonstandard Cables:** Nonstandard and incorrectly wired cables may cause network collisions and other network problems, and can seriously impair network performance. A category 5 or greater cable tester is a recommended tool for every network installation.

- **Check the Port Configuration:** A port on your switch may not be operating as expected because it is administratively disabled in the configuration. It may also be placed into a “blocking” state by a protocol operating on the port (dynamic VLANs), or LACP (dynamic trunking). For example, the normal operation of the spanning tree, GVRP, LACP, and other features may put the port in a blocking state.

Use the switch console to determine the port configuration and verify that there is not an improper or undesired configuration of any of the switch features that may be affecting the port.

Diagnosing with the LEDs

Table 11: Front Panel LED Behavior

Switch LEDs	Function	State	Meaning
Back LED	Status of modular components installed in the back of the chassis (not applicable for 6300F switches)	On - Green	Normal
		Slow Flash - Amber	Fault in one of the modules in the back of the chassis
PoE LED	Indicates Port LEDs are showing PoE information (not applicable for non PoE switches)	Off	PoE mode not selected
		On - Green	PoE mode selected
		Slow Flash - Amber	Hardware failure PoE enabled port, PoE mode not selected
		On - Amber	Hardware failure PoE enabled port, PoE mode selected
Spd LED	Indicates Port LEDs are showing speed information	Off	Speed mode not selected
		On - Green	Speed mode selected
		Not Implemented	No fault defined
Stk LED	Indicates Port LEDs are showing stacking mode information	Off	Stacking mode not selected
		On - Green	Stacking mode selected
		On - Amber	A port has a stacking failure. Stacking mode selected
		Slow flash Amber	A port has a stacking failure. Stacking mode not selected
UID LED	User-configurable LED	Off	User defined the

Switch LEDs	Function	State	Meaning
			located LED : OFF
		On/Flash Blue (for 30 min)	User defined the locator LED: On/Flash
Global Status Indicator LED	Overall status of the product	Flash - Green	Self-test in progress during UBOOT and SVOS
		On - Green	Successfully booted AOS-CX
		Flash - Amber	Recoverable faults (e.g. fans, PSU fault)
		On - Amber	Critical faults (e.g. exceed temperature limit)
OOBM Status Indicator LED	Status of OOBM Link connectivity	Off	OOBM port is not connected, no link established
		Half Bright - Green	OOBM port is enabled and established link with partner
		On - Green	Experiencing high bandwidth utilization
		Activity Flicker - Green	% of the time that the LED light up is roughly proportional to the % of full bandwidth utilization of the port
* Press the Mode Select button to switch between User(default), PoE, Spd, or Stk Mode.			

Table 12: Rear Panel LED Behavior

Switch LEDs	Function	State/Mode	Meaning
Fan health LED	Status of fan	On - Green	Normal
		Slow flash - Amber	Fan fault
UID LED	User-configurable LED	Off	User define the locator LED : OFF
		On/Flash (30 min) - blue	User define the locator LED: On/Flash

Switch LEDs	Function	State/Mode	Meaning
PSU Status Indicator LED	Status of power supply	On Green	Normal
		Off	No power, PSU has invalid AC or DC input or invalid DC output
		Slow Flash - Green	Power supply has faulted or warning

Diagnostic Tips

Tip	Problem	Solution
1	The switch is not plugged into an active AC power source, or the switch power supply may have failed.	<ol style="list-style-type: none"> 1. Verify that the power cord is plugged into an active power source and to the switch. Make sure that these connections are snug. 2. Try power cycling the switch by unplugging and plugging the power cord back in. 3. If the power supply LED is still not on, verify that the AC power source works by plugging another device into the outlet. Or try plugging the switch into a different outlet or try a different power cord.
2	A switch hardware failure has occurred. All the LEDs will stay on indefinitely.	Try power cycling the switch. If the fault indication reoccurs, the switch may have failed. Call your Hewlett Packard Enterprise authorized network reseller.
3	The switch has experienced a software failure during self-test.	<ol style="list-style-type: none"> 1. Try resetting the switch by pressing the Reset button on the front of the switch, or by power cycling the switch. 2. If the fault indication reoccurs, attach a console to the switch (as indicated in chapter 2) and configure it to operate. Then, reset the switch. Messages then appear on the console screen and in the console log to identify the error condition. You can view the console log at that point by selecting it from the console Main Menu. <p>If necessary to resolve the problem, contact your Hewlett Packard Enterprise authorized network reseller.</p>
4	One or more of the switch cooling fans may have failed.	Try disconnecting power from the switch and wait a few moments. Then reconnect the power to the switch and check the LEDs again. If the error indication reoccurs, one or more of the fans has failed. Call your Hewlett Packard Enterprise authorized network

Tip	Problem	Solution
		reseller.
5	The network port for which the LED is blinking has experienced a self-test or initialization failure.	<p>Try power cycling the switch. If the fault indication reoccurs, the switch port may have failed. Call your Hewlett Packard Enterprise authorized network reseller.</p> <p>If the port is a pluggable SFP/SFP+ unit, verify it is a pluggable supported by the switch. An unsupported pluggable will be identified with this fault condition. Caution: Use only supported genuine Hewlett Packard Enterprise transceivers with your switch.</p> <p>To verify that the port has failed, try removing and reinstalling the SFP/SFP+. You can do that without having to power off the switch. If the port fault indication reoccurs, you will have to replace the SFP/SFP+ unit.</p>
6	The network connection is not working properly.	<p>Try the following procedures:</p> <ul style="list-style-type: none"> ■ For the indicated port, verify both ends of the cabling, at the switch and the connected device, are connected properly. ■ Verify that the connected device and switch are both powered on and operating correctly. ■ Verify that you have used the correct cable type for the connection: <ul style="list-style-type: none"> ○ For twisted-pair connections to the fixed 10/100 or 10/100/1000 ports, if the port is configured to “Auto” (auto negotiate), either straight-through or crossover cables can be used. This allowance is because of the switch’s “Aruba Auto-MDIX” feature and the Auto MDI/MDI-X feature of the 10/100/1000-T port. <p>NOTE: If the switch port configuration is changed to one of the fixed configuration options (for example, 100 Mbps/Full Duplex), then the port operates as MDI-X only and you must use the correct type of cable for the connection. In general, for connecting an end node (MDI port) to the switch, use straight-through cable; for connecting to MDI-X ports on hubs, other switches, and routers, use crossover cable.</p> <ul style="list-style-type: none"> ○ For fiber-optic connections, verify that the transmit port on the switch is connected to the receive port on the connected device, and the switch receive port is connected to the transmit port on the connected device. ■ For 1000Base-T connections, verify that the network cabling complies with the IEEE 802.3ab standard. Install the cable according to the ANSI/TIA/EIA-568-A-5 specifications. Ensure that

Tip	Problem	Solution
		<p>cable testing complies with the stated limitations for Attenuation, Near-End Crosstalk, Far-End Crosstalk, Equal-Level Far-End Crosstalk (ELFEXT), Multiple Disturber ELFEXT, and Return Loss.</p> <p>The cable verification process must include all patch cables from any end devices, including the switch, to any patch panels in the cabling path.</p> <ul style="list-style-type: none"> ■ Verify that the port has not been disabled through a switch configuration change. <p>You can use the console interface, or, if you have configured an IP address on the switch, use the web browser interface or AirWave network management software to determine the state of the port and re-enable the port if necessary.</p> <ul style="list-style-type: none"> ■ Verify that the switch port configuration matches the configuration of the attached device. For example, if the switch port is configured as "Auto", the port on the attached device also MUST be configured as "Auto". Depending on the port type, twisted-pair or fiber-optic, if the configurations do not match, the results could be an unreliable connection, or no link at all. ■ If the other procedures do not resolve the problem, try using a different port or a different cable.
7	<p>The port or remote link partner may be improperly configured, or the port may be in a "blocking" state by the normal operation of protocols, such as Spanning Tree, LACP, or GVRP features.</p>	<ul style="list-style-type: none"> ■ Ensure that the device at the other end of the connection indicates a good link to the switch. If it does not, the problem may be with the cabling between the devices, the connectors on the cable, or the configuration of the device on the remote end of the cable. ■ Use the switch console to check the configuration on the port to confirm whether the port is administratively disabled or placed in a "blocking" state by the normal operation of one or more protocols. <ul style="list-style-type: none"> ○ Check the Port Status using the show interfaces command to confirm whether the port is configured as "disabled". ○ To confirm which protocols are operating on the port, review the switch configuration. Use the appropriate feature show commands to confirm whether the port is put into a "blocking" state. ■ For software troubleshooting tips, see the chapter "Troubleshooting" in the <i>Management and Configuration Guide</i> for your switch at

Tip	Problem	Solution
		https://www.hpe.com/networking/support .
8	A redundant power supply has experienced a fault.	At least one power supply must be operating properly. To make sure that the power supply is plugged in to an active power source, check the power supply. If the power supply is operating but the LEDs are still blinking, the power supply may have failed. Unplug the power supply, wait for 5 seconds for residual charge to dissipate, and then plug the power supply. If the fault light is still blinking, replace the power supply.
9	The switch has overheated.	Check to ensure that the fans are functioning correctly.
10	The port may have an internal hardware failure. The port may be denied PoE power. The port may be detecting an external PD fault.	Check the port for a hardware failure. Doing so may require a reboot of the switch. Check the port for correct PoE configuration and allocation. Also check the external PD for a fault.
11	A redundant power supply is not connected to an active AC power source.	(At least one power supply must be operating properly.) Connect the unplugged power supply to an AC power source, using a supported power cord for your country/region.

Proactive networking

The switches have built-in management capabilities that proactively help you manage your network, they include:

- Finding and helping you fix the most common network error conditions (for example, faulty network cabling, and nonstandard network topologies).
- Informing you of the problem with clear, easy-to-understand messages.
- Recommending network configuration changes to enhance the performance of your network.

The following interfaces provide tests, indicators, and an event log that can be used to monitor the switch and its network connections:

- A graphical web browser interface that you can use to manage your switch from a PC running a supported web browser, for example Microsoft Internet Explorer and Firefox.
- A full-featured easy-to-use console interface that you can access by connecting a standard terminal or PC running a terminal emulator to the switch console port using an USB-C to USB-A cable (sold separately). The console command-line interface is also accessible through a Telnet or SSH connection.

Hardware diagnostic tests

Testing the switch by resetting it

If you believe the switch is not operating correctly, you can reset the switch to test its circuitry and operating code. To reset a switch, try any of the following:

- Unplug and plug in the power cord (power cycling).
- Press the Reset button on the front of the switch.
- Reboot the switch via the management console's `boot system` command.

Power cycling the switch and pressing the Reset button both cause the switch to perform its power-on self test, which almost always will resolve any temporary operational problems. These reset processes also cause any network traffic counters to be reset to zero, and cause the System Up Time timer to reset to zero.

Checking the switch LEDs

See [Switch and Port LEDs on Front of the Switches](#) for information on interpreting the LED patterns and LED behaviors.

Checking console messages

Useful diagnostic messages may be displayed on the console screen when you reset a switch. Connect a PC running a VT-100 terminal emulator program or a standard VT-100 terminal to the switch console port. Configure the terminal to run at 115200 baud, and with the other terminal communication settings.

When you reset the switch, note the messages that are displayed. Additionally, you can check the switch event log, which can be accessed from the console using the `show log` command, or from the console main menu.

Testing twisted-pair cabling

Network cables that fail to provide a link or provide an unreliable link between the switch and the connected network device may not be compatible with the IEEE 802.3 Type 10Base-T, 100Base-TX, or 1000Base-T standards. The twisted-pair cables attached to the switch must be compatible with the appropriate standards. To verify your cable is compatible with these standards, use a qualified cable test device.

Testing switch-to-device network communications

The following communication tests can verify that the network is operating correctly between the switch and any connected device that can respond correctly to the communication test.

- Link Test: A physical layer test that sends IEEE 802.2 test packets to any device identified by its MAC address.
- Ping Test: A network layer test used on IP networks that sends test packets to any device identified by its IP address.

These tests can be performed through the switch console interface. Use a terminal connected directly to the switch or through a Telnet connection, or from the switch web browser interface. For more information, see the *Fundamentals Guide* for your switch.

These tests can also be performed from an SNMP network management station running a program that can manage the switch, like AirWave.

Testing end-to-end network communications

Both the switch and the cabling can be tested by running an end-to-end communications test. This is a test that sends known data from one network device to another through the switch. For example, if you have two PCs on the network that have LAN adapters between which you can run a link-level test or Ping test through the switch, you can use this test to verify that the entire communication path between the two PCs is functioning correctly. See your LAN adapter documentation for more information on running a link test or Ping test.

Restoring the factory default configuration

As part of your troubleshooting process on the switch, it may become necessary to return the switch configuration to the factory default settings. This process momentarily interrupts the switch operation, clears any passwords, clears the console event log, resets the network counters to zero, performs a complete self-test, and reboots the switch into its factory default configuration, including deleting the IP address, if one is configured.



This process removes all switch configuration changes made from the factory default settings. This operation includes, for example, configuration of VLANs, spanning tree, and trunks. Returning the configuration of these features to their factory default settings (usually disabling them) may result in network connectivity issues. If the switch has a valid configuration, and you are restoring the factory default settings for a reason other than configuration problems, save the switch configuration prior to performing the factory default reset. After the reset and resolution of the original problem, you can restore the saved configuration to the switch.

You can restore the factory default configuration either on the switch console or on the switch itself.

To restore the factory default configuration using the console, execute the `erase startup-config` command from the console command prompt.

Downloading new switch software

Software updates can be downloaded to the switch through several methods. For more information, see [Support and Other Resources](#).

Physical and environmental

Switch	Dimensions (W x D x H)	Weight
Aruba 6300F 48-port 1GbE Class 4 PoE and 4-port SFP56 Switch (JL665A)	(44.2 x 32.7 x 4.4 cm)	(5.1 kg)
Aruba 6300F 24-port 1GbE Class 4 PoE and 4-port SFP56 Switch (JL666A)		(4.95 kg)
Aruba 6300F 48-port 1GbE and 4-port SFP56 Switch (JL667A)		(4.46 kg)
Aruba 6300F 24-port 1GbE and 4-port SFP56 Switch (JL668A)		(4.36 kg)
Aruba 6300M 48G Class 4 PoE and 4-port SFP56 Switch (JL661A)	(44.2 x 38.5 x 4.4 cm)	(5.16 kg)
Aruba 6300M 24G Class 4 PoE and 4-port SFP56 Switch (JL662A)		(5 kg)
Aruba 6300M 48G and 4-port SFP56 Switch (JL663A)		(4.95 kg)
Aruba 6300M 24G and 4-port SFP56 Switch (JL664A)		(4.81 kg)
Aruba 6300M 48 HPE Smart Rate Class 6 PoE 1/2.5/5G (JL659A)		(6.02 kg)
Aruba 6300M 24 HPE Smart Rate Class 6 PoE 1/2.5/5G (JL660A)		(5.42 kg)
Aruba 6300M 24 SFP+ (JL658A)		(5.11 kg)
Aruba 6300M 48-port 1GbE and 4-port SFP56 Power-to-Port 2 Fan Trays 1 PSU Bundle (JL762A)		(5.7 kg)

Table 13: Removable Parts

Item	Weight
JL086A Power supply	1.83 lb (0.83 kg)
JL087A Power supply	1.94 lb (0.88 kg)

Item	Weight
JL670A Power supply	2.03 lb (0.92 kg)
JL085A Power supply	1.52 lb (0.69 kg)
JL760A Power supply*	1.3 lb (0.57 kg)
5066-4457 Power supply blank	0.31 lb (0.14 kg)
JL757A DC power supply	1.55 lbs (0.705 kg)
JL758 DC power supply	2.1 lbs (0.955 kg)
JL669A Aruba 6300M Fan Tray	0.46 lb (0.21 kg)
JL761A Aruba 6300M Power-to-Port Fan Tray	0.46 lb (0.21 kg)
5300-0908 Fan blank	0.18 lb (0.08 kg)

*For use only with the JL762A switch.

Table 14: Environmental

	Aruba 6300M (JL658A, JL659A, JL660A, JL661A, JL662A, JL663A, JL664A, JL762A)	Aruba 6300F (JL665A, JL666A, JL667A, JL668A)
Operating temperature	32°F to 113°F (0°C to 45°C) up to 5000 ft derate -1°C for every 1000 ft from 5000 ft to 10000 ft	32°F to 113°F (0°C to 45°C) up to 5000 ft derate -1°C for every 1000 ft from 5000 ft to 10000 ft
Operating relative humidity	15% to 95% @ 104°F (40°C) non-condensing	15% to 95% @ 104°F (40°C) non-condensing
Non-operating temperature	-40°F to 158°F (-40°C to 70°C) up to 15000 ft	-40°F to 158°F (-40°C to 70°C) up to 15000 ft
Non-operating storage relative humidity	15% to 90% @ 149°F (65°C) non-condensing	15% to 90% @ 149°F (65°C) non-condensing
Max operating altitude	10000 feet (3 km) Max	10000 feet (3 km) Max
Max non-operating altitude	15000 feet (4.6 km) Max	15000 feet (4.6 km) Max

Electrical

	Aruba 6300M PoE Switches (JL659A, JL660A, JL661A, JL662A)	
Power supply	JL670A	JL670A
AC voltage	110V-120V	200V-240V
Maximum current	11A	9A
Frequency range	50-60 Hz	50-60 Hz
Maximum power	1050W Max	1600W Max

	Aruba 6300M PoE Switches (JL659A, JL660A, JL661A, JL662A)	
Power supply AC voltage Maximum current Frequency range Maximum power	JL086A 100V-240V 8A-3.5A 50-60 Hz 680W Max	JL087A 110V-240V 12A-5A 50-60 Hz 1050W Max
Power supply DC input range (nominal) DC input range (maximum) Maximum current Maximum Power	JL758A -48V to -60V -36V to -72V 32A 1050W Max	

	Aruba 6300M Non-PoE Switches (JL658A, JL663A, JL664A)	Aruba 6300M Power-to-Port Bundle (JL762A)
Power supply AC voltage Maximum current Frequency range Maximum Power	JL085A 100V-240V 3A-1.2A 50-60 Hz 250W Max	JL760A 100V-240V 3A-1.2A 50-60 Hz 250W Max
Power supply: DC input range (nominal) DC input range (maximum) Maximum current Maximum Power	JL757A -48V to -60V -36V to -72V 8.2A 250W Max	

	Aruba 6300F PoE Switches (JL665A, JL666A)	
AC voltage Maximum current Frequency range Maximum Power	100V-120V 11A 50-60 Hz 950W Max*	200V-240V 6A 50-60 Hz 950W Max*

*For 24 port models, total power will be limited to 580W.

	Aruba 6300F Non-PoE Switches (JL667A, JL668A)	
AC voltage Maximum current Frequency range Maximum Power	100V-120V 2.5A 50-60 Hz 200W Max	200V-240V 1.4A 50-60 Hz 200W Max

Acoustics

Product*	Acoustics
JL658A Aruba 6300M 24SFP+ /4SFP56 Swch	Sound Power (LWAd) 4.9 Bel Sound Pressure (LpAm) (Bystander) 31.0 dB

Product*	Acoustics
JL659A Aruba 6300M 48SR5 CL6 PoE 4SFP56 Swch	Sound Power (LWAd) 4.8 Bel Sound Pressure (LpAm) (Bystander) 30.6 dB
JL660A Aruba 6300M 24SR5 CL6 PoE 4SFP56 Swch	Sound Power (LWAd) 5.2 Bel Sound Pressure (LpAm) (Bystander) 34.2 dB
JL661A Aruba 6300M 48G CL4 PoE 4SFP56 Swch	Sound Power (LWAd) 4.7 Bel Sound Pressure (LpAm) (Bystander) 29.8 dB
JL662A Aruba 6300F 24G CL4 PoE 4SFP56 Swch	Sound Power (LWAd) 4.7 Bel Sound Pressure (LpAm) (Bystander) 29.4 dB
JL663A Aruba 6300M 48G /4SFP56 Swch	Sound Power (LWAd) 4.6 Bel Sound Pressure (LpAm) (Bystander) 28.7 dB
JL664A Aruba 6300M 24G /4SFP56 Swch	Sound Power (LWAd) 4.6 Bel Sound Pressure (LpAm) (Bystander) 28.6 dB
JL762A Aruba 6300M 48G Pwr2Prt 2F 1PS Bdl**	Sound Power (LWAd) 5.0 Bel Sound Pressure (LpAm) (Bystander) 32.5 dB
JL665A Aruba 6300F 48G CL4 PoE 4SFP56 Swch	Sound Power (LWAd) 5.2 Bel Sound Pressure (LpAm) (Bystander) 34.9 dB
JL666A Aruba 6300F 24G CL4 PoE 4SFP56 Swch	Sound Power (LWAd) 5.0 Bel Sound Pressure (LpAm) (Bystander) 32.3 dB
JL667A Aruba 6300F 48G 4SFP56 Swch	Sound Power (LWAd) 4.9 Bel Sound Pressure (LpAm) (Bystander) 31.5 dB
JL668A Aruba 6300F 24G 4SFP56 Swch	Sound Power (LWAd) 4.9 Bel Sound Pressure (LpAm) (Bystander) 31.6 dB

*Acoustic levels based on the JL087A power supply.

**Acoustic levels based on the JL760A power supply.

Safety

Lasers

EN 60825-1:2007 / IEC 60825-1:2007 Class 1

Class 1 Laser Products / Laser Klasse 1

(Applicable for accessories - Optical Transceivers only)

Safety

Europe	EN 60950-1:2006 +A11:2009 +A1:2010 +A12:2011 + A2:2013 EN 62368-1:2014 +A11:2017
US	UL 60950-1 2nd Ed.
Canada	CAN/CSA-C22.2 No. 60950-1-07

Worldwide	IEC 60950-1:2005 w/all known National Deviations IEC 62368-1:2014 2nd Ed.
Taiwan	CNS-14336-1

EMC

Europe	EN 55032:2015 +AC:2016, Class A EN 55024:2010 EN 55035:2017 EN 61000-3-2:2014 EN 61000-3-3:2013
US	FCC CFR47 part 15B: 2010, Class A
Canada	ICES-003 Class A
Worldwide	VCCI Class A CISPR 32 Ed 2.0: 2015 + COR1:2016, Class A CISPR 24:2010 CISPR 35:2016

Connectivity standards

Table 15: Technology Standards and Safety Compliance

Technology	Compatible with these IEEE standards	Laser Safety Information		
		EN/IEC Standard Compliance	SFP ("mini-GBIC") Lasers	SFP+Lasers
10-T100-TX1000-T10GBASE-T	IEEE 802.3 10BASE-T IEEE 802.3u 100BASE-TX IEEE 802.3ab 1000BASE-T IEEE 802.3an 10GBASE-T (with transceiver)			
2.5G and 5G Twisted-Pair Copper	HPE Smart Rate IEEE 802.3bz			
100-FX	IEEE 802.3u 100BASE-FX	EN/IEC 60825	Class 1 Laser Product Laser Klasse 1	
1000-SX	IEEE 802.3z 1000BASE-SX	EN/IEC 60825	Class 1 Laser Product Laser Klasse 1	
1000-LX	IEEE 802.3z 1000BASE-LX	EN/IEC 60825	Class 1 Laser Product Laser Klasse 1	
1000-LH	(not an IEEE standard)	EN/IEC 60825	Class 1 Laser Product	

		Laser Safety Information		
Technology	Compatible with these IEEE standards	EN/IEC Standard Compliance	SFP ("mini-GBIC") Lasers	SFP+Lasers
			Laser Klasse 1	
10-Gig Direct Attach	(not an IEEE standard)			
10-Gig SR	IEEE 802.3ae 10GBASE-SR	EN/IEC 60825		Class 1 Laser Product Laser Klasse 1
10-Gig LRM	IEEE 802.3aq 10GBASE-LRM	EN/IEC 60825		Class 1 Laser Product Laser Klasse 1
10-Gig LR	IEEE 802.3ae 10GBASE-LR	EN/IEC 60825		Class 1 Laser Product Laser Klasse 1
10-Gig ER	IEEE 802.3ae 10GBASE-ER	EN/IEC 60825		Class 1 Laser Product Laser Klasse 1
40-Gig SR4	IEEE 802.3ba 40GBASE-SR4	EN/IEC 60825		Class 1 Laser Product Laser Klasse 1
40-Gig eSR4	IEEE 802.3ba 40GBASE-SR4	En/IC 60825		Class 1 Laser Product Laser Klasse 1
40-Gig LR4	IEEE 802.3ae 40GBASE-LR4	EN/IC 60825		Class 1 Laser Product Laser Klasse 1

This section includes switch connector information and network cable information for cables used with the Aruba switches.



Incorrectly wired cabling is a common cause of problems for LAN communications. Aruba recommends that you work with a qualified LAN cable installer for assistance with your cabling requirements.

Cabling specifications

Table 16: Supported Cables

J9281D	Aruba 10G SFP+ to SFP+ 1m Direct Attach Copper Cable
J9283D	Aruba 10G SFP+ to SFP+ 3m Direct Attach Copper Cable
JL487A	Aruba 25G SFP28 to SFP28 0.65m Direct Attach Copper Cable
JL488A	Aruba 25G SFP28 to SFP28 3m Direct Attach Copper Cable
JL489A	Aruba 25G SFP28 to SFP28 5m Direct Attach Copper Cable
R0M46A	Aruba 50G SFP56 to SFP56 0.65m DAC Cable
R0M47A	Aruba 50G SFP56 to SFP56 3m DAC Cable

Table 17: Cabling Specifications

Twisted-pair copper	10 Mbps Operation	Category 3, 4 or 5, 100-ohm unshielded twisted-pair (UTP) or shielded twisted-pair (STP) cable, complying with IEEE 802.3 10BASE-T specifications.
	100 Mbps Operation	Category 5, 100-ohm UTP, or STP cable, complying with IEEE 802.3u 100BASE-TX specifications.
	1000 Mbps Operation	Category 5, 100-ohm 4-pair UTP or STP cable, complying with IEEE 802.3ab 1000BASE-T specifications—Category 5e or better is recommended.
	2.5 Gbps Operation	Category 5e, 100-ohm-4-pair UTP, or STP cable, complying with IEEE 802.bz 1000BASE-T specifications.
	5 Gbps Operation	Category 5e or better, 100-ohm-4-pair UTP or STP cable. Category 6 or better is recommended.
	10 Gbps Operation	Category 6 or 6A, 100-ohm 4-pair UTP cable, or Category 6A or 7, 100-ohm 4-pair STP cable, complying with IEEE 802.3an 10GBASE-T specifications.

Twinaxial copper	Direct attach cables	One-piece devices consisting of a cable with SFP+ connectors permanently attached to each end, complying with SFF 8431 SFP+ specifications.
Multimode fiber		62.5/125 μm or 50/125 μm (core/cladding) diameter, low metal content, graded index fiber-optic cables, complying with the ITU-T G.651 and ISO/IEC 793-2 Type A1b or A1a standards respectively. ¹
Single mode fiber		9/125 μm (core/cladding) diameter, low metal content fiber-optic cables, complying with the ITU-T G.652 and ISO/IEC 793-2 Type B1 standards.
¹ A mode conditioning patch cord may be needed for some Gigabit-LX and 10-Gigabit LRM installations.		

Note on Multimode and Single Mode Fiber

Attenuators may be required for some transceiver techs and cable length

Note on 1000BASE-T Cable Requirements

The Category 5 networking cables that work for 100BASE-TX connections also work for 1000BASE-T, as long as all four-pairs are connected. But, for the most robust connections, use cabling that complies with the Category 5e specifications. This specification is described in Addendum 5 to the TIA-568-A standard (ANSI/TIA/EIA-568-A-5).

Because of the increased speed provided by 1000BASE-T (Gigabit-T), network cable quality is more important than for either 10BASE-T or 100BASE-TX. Cabling plants being used to carry 1000BASE-T networking must comply with the IEEE 802.3ab standards. In particular, the cabling must pass tests for Attenuation, Near-End Crosstalk (NEXT), and Far-End Crosstalk (FEXT). Additionally, unlike the cables for 100BASE-TX, the 1000BASE-T cables must pass tests for Equal-Level Far-End Crosstalk (ELFEXT) and Return Loss.

When testing your cabling, be sure to include the patch cables that connect the switch and other end devices to the patch panels on your site. The patch cables are frequently overlooked when testing cable and they must also comply with the cabling standards.

Note on HPE Smart Rate 2.5 Gb/s Cable Requirements

The 2.5 Gb/s Smart Rate operates on cable installations that are designed to support 1000BASE-T operation. The cabling installation must meet the 1000BASE-T link segment characteristics described in IEEE 802.3-2012. The installation must also meet the Category 5e or Class D limits described in the ANSI/TIA/EIA 568-C.2 and ISO/IEC 11801 standards, respectively.

Note on HPE Smart Rate 5Gb/s Cable Requirements

The 5 Gb/s Smart Rate operates on most Category 5e and Category 6 cable installations. Category 5e or Class D installations must meet the ANSI/TIA/EIA 568-C.2 or ISO/IEC 11801 transmission parameter limits extended to 200MHz. Category 6 or Class E installations must meet their respective transmission parameter limits as described in ANSI/TIA/EIA 568-C.2 or ISO/IEC 11801.

Also, to transmission performance, 5 Gb/s Smart Rate can be sensitive to alien noise. Such noise can come from either nearby cables or background noise from the environment. Therefore, cabling must additionally be tested for Alien Near-End Crosstalk (ANEXT) and Alien Equal-Level-Far-End Crosstalk (AELFEXT). Depending on the cabling installation, the magnitude of alien crosstalk may further limit the maximum supported cabling distance.

Hewlett Packard Enterprise recommends doing cable dressing carefully and in compliance with recommendations in the TIA TSB-155-A and ISO/IEC TR-24750.

Note on 10GBASE-T Cable Requirements

The Category 6 networking cables that work for 1000BASE-T connections may work for 10GBASE-T. The distance must be less than 55m, and the cable installation must be tested for compliance to IEEE requirements. But, for the most robust connections, use cabling that complies with the Category 6A or Category 7 specifications, as described in the TIA-568-C (ANSI/TIA-568-C.2) and ISO/IEC 11801 standards. 10GBASE-T is a sophisticated technology that relies upon high-quality cable installations. It is sensitive to Alien Near End Crosstalk (ANEXT). This can affect the cable due to other cables placed close to the data cables. Hewlett Packard Enterprise recommends doing cable dressing carefully and in compliance with recommendations in the TIA TSB-155A.

Like 1000BASE-T, 10GBASE-T requires testing of all the crosstalk and return loss parameters described preceding "Note on 1000BASE-T cable requirements", and also ANEXT.

In addition to ANEXT, 10GBASE-T is more sensitive to external electrical noise in the environment. Hewlett Packard Enterprise recommends keeping radio transmitters and other sources of high frequency continuous wave radio frequency away from LAN cables.

When testing your cabling, be sure to include the patch cables that connect the switch and other end devices to the patch panels on your site. The patch cables are frequently overlooked when testing cable and they must also comply with the cabling standards. For 10GBASE-T, Category 6 patch cables are sensitive to movement once link has been established, and could cause link to drop if moved. Therefore, Hewlett Packard Enterprise recommends using Category 6A patch cables. As an alternative, use cable management options to tie down (dress) the Category 6 patch cables so they cannot move.

For Conducted and Radiated Immunity in accordance with EN55024, the Aruba switches are limited to Performance Criteria A with shielded cables (CAT6/6A).

Technology distance specifications

Table 18: Technology Distance Specifications

Technology	Supported Cable Type	Multimode Fibermodal Bandwidth	Supported Distances
100-FX	multimode fiber	any	up to 2,000 meters
1000-T	twisted-pair copper	N/A	up to 100 meters
2.5Gb/s HPE Smart Rate	twisted-pair copper	N/A	up to 100 meters
5Gb/s HPE Smart Rate	twisted-pair copper	N/A	Cat 5e - up to 100 meters ¹ Cat 6 - up to 100 meters ² Cat 6A - up to 100 meters
10GBASE-T	twisted-pair copper	N/A	Cat 6 unshielded - up to 55 meters ³ Cat 6 shielded - up to 100 meters ³ Cat 6A unshielded - up to 100 meters Cat 6A shielded - up to 100 meters Cat 7 shielded - up to 100 meters

Technology	Supported Cable Type	Multimode Fibermodal Bandwidth	Supported Distances
1000-SX	multimode fiber	160 MHz*km 200 MHz*km 400 MHz*km 500 MHz*km	2 - 220 meters 2 - 275 meters 2 - 500 meters 2 - 550 meters
1000-LX	multimode fiber single mode fiber	400 MHz*km 500 MHz*km N/A	2 - 550 meters 2 - 550 meters 2 - 10,000 meters
1000-LH	single mode fiber	N/A	10 - 70,000 meters ⁴
1000-BX	single mode fiber	N/A	0.5 - 10,000 meters
10-Gig Direct Attach	twinaxial copper	N/A	(various lengths offered)
10-Gig SR	multimode fiber	160 MHz*km 200 MHz*km 400 MHz*km 500 MHz*km 2000 MHz*km	2 - 26 meters 2 - 33 meters 2 - 66 meters 2 - 82 meters 2 - 300 meters
10-Gig LR	single mode fiber	N/A	2 - 10,000 meters
10-Gig ER	single mode fiber	N/A	2 - 40,000 meters
40-Gig SR4	single mode fiber	2000 MHz*km 4700 MHz*km	2 - 100 meters 2 - 150 meters
40-Gig ESR4	multimode fiber	2000 MHz*km 4700 MHz*km	2 - 300 meters 2 - 400 meters
40-Gig LR4	single mode fiber	N/A	2 - 10,000 meters
<p>1 Cat 5e cabling requires testing to 200 MHz operation and additionally for ANEXT and AELFEXT. The maximum supported distances may be reduced depending on alien crosstalk levels. The support for untested cable installations is best-effort.</p> <p>2 Cat 6 cabling requires testing for ANEXT and AELFEXT. The maximum supported distances may be reduced depending on alien crosstalk levels.</p> <p>3 Cat 6 cabling requires TIA TSB-155A testing for 500 MHz operation and ANEXT.</p> <p>4 For distances less than 20km, a 10dB attenuator must be used. For distances between 20km and 40km, a 5dB attenuator must be used. Attenuators can be purchased from most cable vendors.</p>			

Mode conditioning patch cord

The following information applies to installations in which multimode fiber-optic cables are connected to a Gigabit-LX port or a 10-Gigabit LRM port. Multimode cable has a design characteristic called “Differential Mode Delay”, which requires the transmission signals be “conditioned” to compensate for the cable design and thus prevent resulting transmission errors.

Under certain circumstances, depending on the cable used and the lengths of the cable runs, an external Mode Conditioning Patch Cord may need to be installed between the Gigabit-LX or 10-Gigabit LRM transmitting device and the multimode network cable to provide the transmission conditioning. If you experience a high number of transmission errors on those ports, usually CRC or FCS errors, you may need to

install one of these patch cords between the fiber-optic port in your switch and your multimode fiber-optic network cabling, at both ends of the network link.

The patch cord consists of a short length of single mode fiber cable coupled to graded-index multimode fiber cable on the transmit side, and only multimode cable on the receive side. The section of single mode fiber is connected in such a way that it minimizes the effects of the differential mode delay in the multimode cable.



Most of the time, if you are using good quality graded-index multimode fiber cable that adheres to the standards listed in [Cabling specifications](#), there should not be a need to use mode conditioning patch cords in your network. This is especially true if the fiber runs in your network are relatively short. For 10-Gigabit LRM using OM3 cable (50 μ m multimode @ 1500/500 MHz*km), a mode conditioning patch cord is not required. Other multimode cables may require mode conditioning patch cords to achieve the LRM maximum distances.

Installing the patch cord

As shown in the illustration below, connect the patch cord to the Hewlett Packard Enterprise transceiver with the section of single mode fiber plugged in to the Tx (transmit) port. Then, connect the other end of the patch cord to your network cabling patch panel, or directly to the network multimode fiber.

If you connect the patch cord directly to the network cabling, you may need to install a female-to-female adapter to allow the cables to be connected together.

Figure 1 Connecting a Mode Conditioning Patch Cord for Gigabit-LX

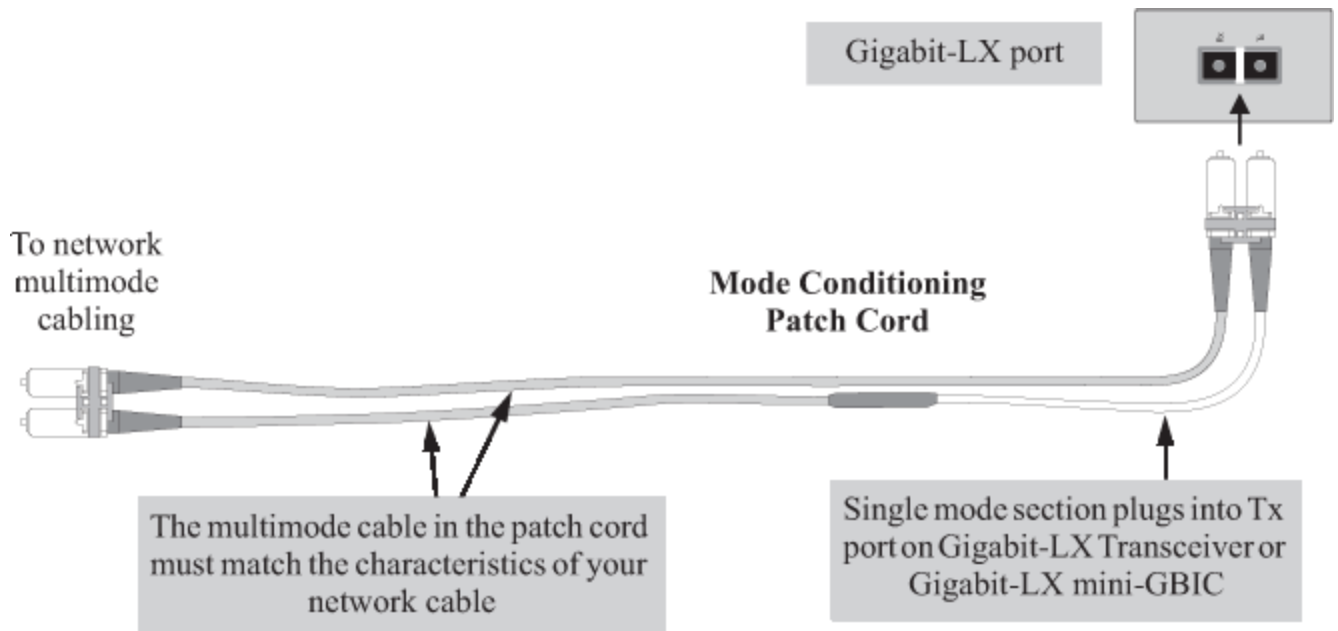

Be sure to purchase a patch cord that has appropriate connectors on each end, and has multimode fibers that match the characteristics of the multimode fiber in your network. Most important, the core diameter of the multimode patch cord must match the core diameter of the multimode cable infrastructure (either 50 or 62.5 microns).

Twisted-pair cable/connector pin-outs

Auto-MDIX Feature:

The 10/100/1000-T ports support the IEEE 802.3ab standard, which includes the “Auto MDI/MDI-X” feature. In the default configuration, “Auto”, the ports on the switch will automatically detect the type of port on the connected device and operate as either an MDI or MDI-X port, whichever is appropriate. So for any connection, a straight-through twisted-pair cable can be used. You no longer have to use crossover cables, although crossover cables can also be used for any of the connections.

If you connect a 6300M switch twisted-pair port to another switch or hub, which typically have MDI-X ports, the 6300M port automatically operates as an MDI port. If you connect it to an end node, such as a server or PC, which typically have MDI ports, the 6300M switch port operates as an MDI-X port. In all cases, you can use standard straight-through cables or crossover cables.

If you use a correctly-wired crossover cable, though, the switch will still be able to automatically detect the MDI/MDI-X operation and link correctly to the connected device.

Other Wiring Rules:

- All twisted-pair wires used for 10 Mbps, and 100 Mbps operation must be twisted through the entire length of the cable. The wiring sequence must conform to EIA/TIA 568-B (not USOC). See “Pin Assignments” later in this appendix for a listing of the signals used on each pin.
- For 1000Base-T connections, all four pairs of wires in the cable must be available for data transmission.
- For 10 Mbps connections to the ports, you can use Category 3, 4, or 5 unshielded twisted-pair cable, as supported by the IEEE 802.3 Type 10Base-T standard.
- For 100 Mbps connections to the ports, use 100-ohm Category 5 UTP or STP cable only, as supported by the IEEE 802.3u Type 100Base-TX standard.
- For 1000 Mbps and SmartRate connections, 100-ohm Category 5e or better cabling is recommended.

Straight-through twisted-pair cable for 10 Mbps or 100 Mbps network connections

Because of the Aruba Auto-MDIX operation of the 10/100 ports on the switch, for all network connections, to PCs, servers or other end nodes, or to hubs or other switches, you can use straight-through cables.

If any of these ports are given a fixed configuration, for example 100 Mbps/Full Duplex, the ports operate as MDI-X ports, and straight-through cables must be then used for connections to PC NICs and other MDI ports.

Figure 1 *Cable Diagram*

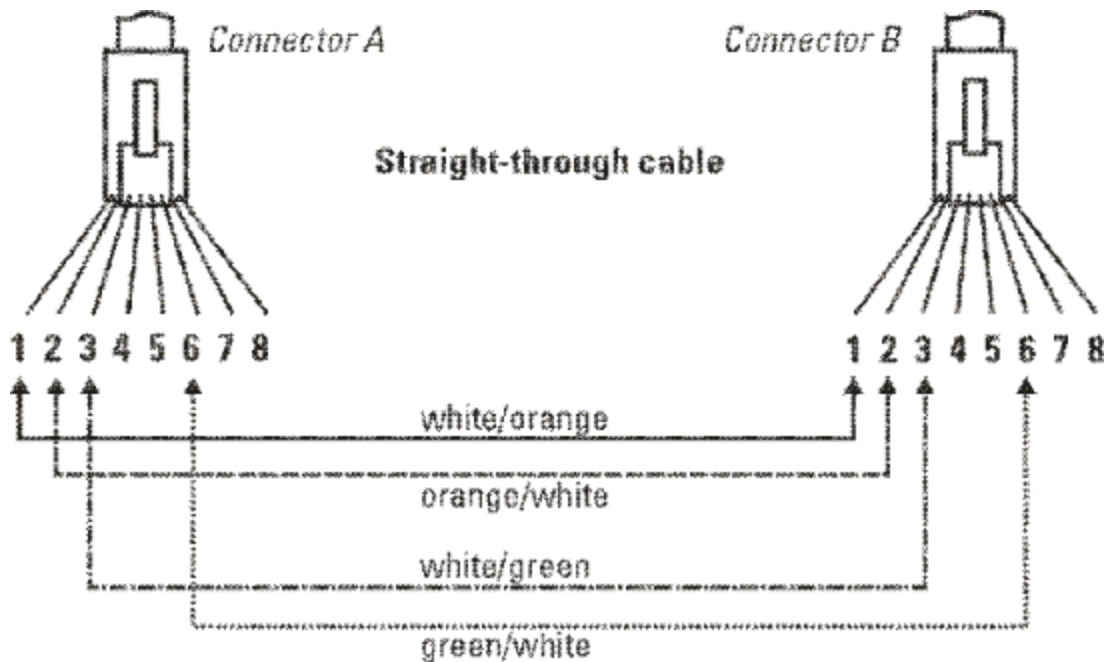

Pins 1 and 2 on connector "A" must be wired as a twisted pair to pins 1 and 2 on connector "B".
 Pins 3 and 6 on connector "A" must be wired as a twisted pair to pins 3 and 6 on connector "B".
 Pins 4, 5, 7, and 8 are not used in this application, although they may be wired in the cable.

Table 1: Pin Assignments

Switch End (MDI-X)			Computer, Transceiver, or Other End	
Signal	Pins		Pins	Signal
receive +	1	<-----	1	transmit +
receive -	2	<-----	2	transmit -
transmit +	3	----->	3	receive +
transmit -	6	----->	6	receive -

Crossover twisted-pair cable for 10 Mbps or 100 Mbps network connection

The Auto-MDIX operation of the 10/100 ports on the switch also allows you to use crossover cables for all network connections, to PCs, servers or other end nodes, or to hubs or other switches.

If any of these ports are given a fixed configuration, for example 100 Mbps/Full Duplex, the ports operate as MDI-X ports, and crossover cables must be then used for connections to hubs or switches or other MDI-X network devices.

Figure 1 Cable Diagram

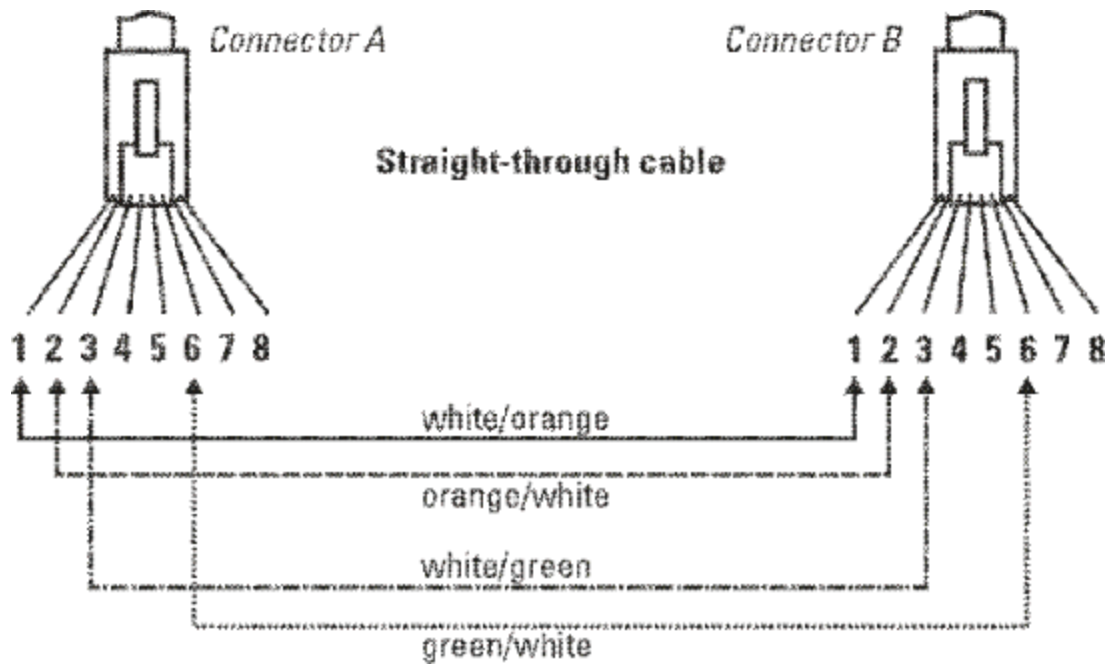

Pins 1 and 2 on connector "A" must be wired as a twisted pair to pins 1 and 2 on connector "B".
 Pins 3 and 6 on connector "A" must be wired as a twisted pair to pins 3 and 6 on connector "B".
 Pins 4, 5, 7, and 8 are not used in this application, although they may be wired in the cable.



Table 1: Pin Assignments

Switch end (MDI-X)		Hub or switch port, or other MDI-X port end	
Signal	Pins	Pins	Signal
receive +	1	6	transmit -
receive -	2	3	transmit +
transmit +	3	2	receive -
transmit -	6	1	receive +

Straight-through twisted-pair cable for 1000 Mbps network connections

1000Base-T connections require that all four pairs or wires be connected.

Figure 1 Cable Diagram

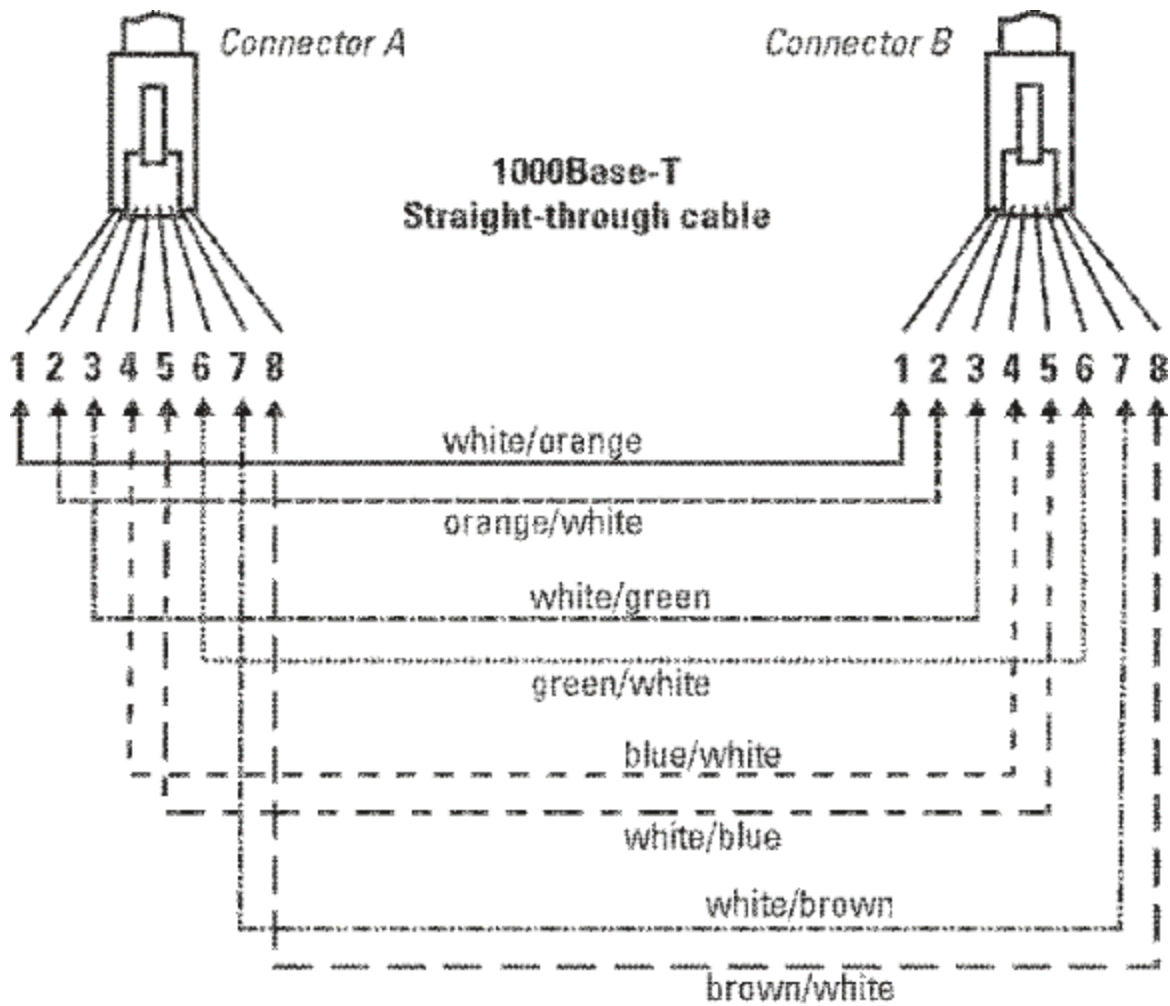

Pins 1 and 2 on connector "A" must be wired as a twisted pair to pins 1 and 2 on connector "B".

Pins 3 and 6 on connector "A" must be wired as a twisted pair to pins 3 and 6 on connector "B".

Pins 4 and 5 on connector "A" must be wired as a twisted pair to pins 4 and 5 on connector "B".

Pins 7 and 8 on connector "A" must be wired as a twisted pair to pins 7 and 8 on connector "B".

For 1000Base-T operation, all four pairs of wires are used for both transmit and receive.



Access Aruba support and updates, and view warranty and regulatory information

Accessing Aruba Support

Aruba Support Services	https://www.arubanetworks.com/support-services/
Aruba Support Portal	https://asp.arubanetworks.com/
North America telephone	1-800-943-4526 (US & Canada Toll-Free Number) +1-408-754-1200 (Primary - Toll Number) +1-650-385-6582 (Backup - Toll Number - Use only when all other numbers are not working)
International telephone	https://www.arubanetworks.com/support-services/contact-support/

Be sure to collect the following information before contacting Support:

- Technical support registration number (if applicable)
- Product name, model or version, and serial number
- Operating system name and version
- Firmware version
- Error messages
- Product-specific reports and logs
- Add-on products or components
- Third-party products or components

Other useful sites

Other websites that can be used to find information:

Airheads social forums and Knowledge Base	https://community.arubanetworks.com/
Software licensing	https://lms.arubanetworks.com/
End-of-Life information	https://www.arubanetworks.com/support-services/end-of-life/
Aruba software and documentation	https://asp.arubanetworks.com/downloads

Accessing Updates

You can access updates from the Aruba Support Portal or the HPE My Networking Website.

Aruba Support Portal

<https://asp.arubanetworks.com/downloads>

If you are unable to find your product in the Aruba Support Portal, you may need to search My Networking, where older networking products can be found:

My Networking

<https://www.hpe.com/networking/support>

To view and update your entitlements, and to link your contracts and warranties with your profile, go to the Hewlett Packard Enterprise Support Center **More Information on Access to Support Materials** page:

<https://support.hpe.com/portal/site/hpsc/aae/home/>

Access to some updates might require product entitlement when accessed through the Hewlett Packard Enterprise Support Center. You must have an HP Passport set up with relevant entitlements.

Some software products provide a mechanism for accessing software updates through the product interface. Review your product documentation to identify the recommended software update method.

To subscribe to eNewsletters and alerts:

<https://asp.arubanetworks.com/notifications/subscriptions> (requires an active Aruba Support Portal (ASP) account to manage subscriptions). Security notices are viewable without an ASP account.

Warranty Information

To view warranty information for your product, go to <https://www.arubanetworks.com/support-services/product-warranties/>.

Regulatory Information

To view the regulatory information for your product, view the *Safety and Compliance Information for Server, Storage, Power, Networking, and Rack Products*, available at <https://www.hpe.com/support/Safety-Compliance-EnterpriseProducts>

Additional regulatory information

Aruba is committed to providing our customers with information about the chemical substances in our products as needed to comply with legal requirements, environmental data (company programs, product recycling, energy efficiency), and safety information and compliance data, (RoHS and WEEE). For more information, see <https://www.arubanetworks.com/company/about-us/environmental-citizenship/>.

Documentation Feedback

Aruba is committed to providing documentation that meets your needs. To help us improve the documentation, send any errors, suggestions, or comments to Documentation Feedback (docsfeedback-switching@hpe.com). When submitting your feedback, include the document title, part number, edition, and publication date located on the front cover of the document. For online help content, include the product name, product version, help edition, and publication date located on the legal notices page.