



Switch Installation

For initial switch setup, assigning the switch IP address, and powering on information, see the switch getting started guide on Cisco.com.

This chapter contains these topics:

- [Safety Warnings, on page 1](#)
- [Box Contents, on page 4](#)
- [Tools and Equipment, on page 4](#)
- [Installation Guidelines, on page 5](#)
- [Verifying Switch Operation, on page 5](#)
- [Planning and Installing a Switch Stack \(Optional\), on page 6](#)
- [Installing the Switch, on page 12](#)
- [Connecting FlexStack modules, on page 19](#)
- [Removing a FlexStack Cable, on page 22](#)
- [Installing the Power Cord Retainer \(Optional\), on page 22](#)
- [Installing SFP Modules, on page 25](#)
- [Connecting to SFP and SFP+ Modules, on page 26](#)
- [10/100/1000 PoE and PoE+Port Connections, on page 28](#)
- [10/100/1000 Port Connections, on page 30](#)
- [Where to Go Next, on page 30](#)

Safety Warnings

This section includes the basic installation caution and warning statements. Read this section before you start the installation procedure. Translations of the warning statements appear in the RCSI guide on Cisco.com.



Warning

Before working on equipment that is connected to power lines, remove jewelry (including rings, necklaces, and watches). Metal objects will heat up when connected to power and ground and can cause serious burns or weld the metal object to the terminals. Statement 43



Warning

Do not stack the chassis on any other equipment. If the chassis falls, it can cause severe bodily injury and equipment damage. Statement 48



Warning This product must be connected to a power-over-ethernet (PoE) IEEE 802.3af compliant power source or an IEC60950 compliant limited power source. Statement 353



Warning Read the wall-mounting instructions carefully before beginning installation. Failure to use the correct hardware or to follow the correct procedures could result in a hazardous situation to people and damage to the system. Statement 378



Warning If a Cisco external power system is not connected to the switch, install the provided connector cover on the back of the switch. Statement 386



Warning Attach only the following Cisco external power system to the switch: PWR-RPS2300 Statement 387



Warning Do not work on the system or connect or disconnect cables during periods of lightning activity. Statement 1001



Warning Read the installation instructions before connecting the system to the power source. Statement 1004



Warning To prevent bodily injury when mounting or servicing this unit in a rack, you must take special precautions to ensure that the system remains stable. The following guidelines are provided to ensure your safety:

- This unit should be mounted at the bottom of the rack if it is the only unit in the rack.
- When mounting this unit in a partially filled rack, load the rack from the bottom to the top with the heaviest component at the bottom of the rack.
- If the rack is provided with stabilizing devices, install the stabilizers before mounting or servicing the unit in the rack.

Statement 1006



Warning Class 1 laser product. Statement 1008



Warning This unit is intended for installation in restricted access areas. A restricted access area can be accessed only through the use of a special tool, lock and key, or other means of security. Statement 1017



Warning The plug-socket combination must be accessible at all times, because it serves as the main disconnecting device. Statement 1019



Warning This equipment must be grounded. Never defeat the ground conductor or operate the equipment in the absence of a suitably installed ground conductor. Contact the appropriate electrical inspection authority or an electrician if you are uncertain that suitable grounding is available. Statement 1024



Warning This unit might have more than one power supply connection. All connections must be removed to de-energize the unit. Statement 1028



Warning Only trained and qualified personnel should be allowed to install, replace, or service this equipment. Statement 1030



Warning Ultimate disposal of this product should be handled according to all national laws and regulations. Statement 1040



Warning For connections outside the building where the equipment is installed, the following ports must be connected through an approved network termination unit with integral circuit protection: 10/100/1000 Ethernet. Statement 1044



Warning When installing or replacing the unit, the ground connection must always be made first and disconnected last. Statement 1046



Warning To prevent the system from overheating, do not operate it in an area that exceeds the maximum recommended ambient temperature of: <113°F (45°C). Statement 1047



Warning This warning symbol means danger. You are in a situation that could cause bodily injury. Before you work on any equipment, be aware of the hazards involved with electrical circuitry and be familiar with standard practices for preventing accidents. Use the statement number provided at the end of each warning to locate its translation in the translated safety warnings that accompanied this device. Statement 1071



Warning Voltages that present a shock hazard may exist on Power over Ethernet (PoE) circuits if interconnections are made using uninsulated exposed metal contacts, conductors, or terminals. Avoid using such interconnection methods, unless the exposed metal parts are located within a restricted access location and users and service people who are authorized within the restricted access location are made aware of the hazard. A restricted access area can be accessed only through the use of a special tool, lock and key or other means of security. Statement 1072



Warning No user-serviceable parts inside. Do not open. Statement 1073



Warning Installation of the equipment must comply with local and national electrical codes. Statement 1074



Warning To prevent airflow restriction, allow clearance around the ventilation openings to be at least: 3 inches (7.6 cm). Statement 1076



Warning Hot surface. Statement 1079

Applies to the Catalyst 2960X-24PSQ-L switches.

Box Contents

The switch getting started guide describes the box contents. If any item is missing or damaged, contact your Cisco representative or reseller for support.

Tools and Equipment

Obtain these necessary tools:

- A Number-2 Phillips screwdriver to rack-mount the switch

Installation Guidelines

When determining where to install the switch, verify that these guidelines are met:

- Clearance to the switch front and rear panel meets these conditions:
 - Front-panel LEDs can be easily read.
 - Access to ports is sufficient for unrestricted cabling.
 - AC power cord can reach from the AC power outlet to the connector on the switch rear panel.
- Cabling is away from sources of electrical noise, such as radios, power lines, and fluorescent lighting fixtures. Make sure that the cabling is safely away from other devices that might damage the cables.
- For switches with the optional 1025-W power-supply module, first rack-mount the switch before installing the power-supply module.
- Make sure power-supply modules are securely inserted in the chassis before moving the switch.
- When connecting or disconnecting the power cord on a switch that is installed above or below a 1025-W power supply-equipped switch, you might need to remove the module from the switch to access the power cord.
- Airflow around the switch and through the vents is unrestricted.
- For the Catalyst 2960X-24PSQ-L switches: Allow these clearances:
 - Top and bottom: 1.75 in. (44.44 mm)
 - Back of switch: 3 in. (76.19 mm)
- Temperature around the unit does not exceed 113°F (45°C). If the switch is installed in a closed or multirack assembly, the temperature around it might be greater than normal room temperature.
- Humidity around the switch does not exceed 95 percent.
- Altitude at the installation site is not greater than 10,000 feet.
- For 10/100/1000 fixed ports, the cable length from a switch to a connected device cannot exceed 328 feet (100 meters).
- Cooling mechanisms, such as fans and blowers in the switch, can draw dust and other particles causing contaminant buildup inside the chassis, which can result in system malfunction. You must install this equipment in an environment as free from dust and foreign conductive material (such as metal flakes from construction activities) as is possible.

Verifying Switch Operation

Before you install the switch in a rack, on a wall, or on a table or shelf, power on the switch and verify that it passes POST.

To power on the switch, plug one end of the AC power cord into the switch AC power connector, and plug the other end into an AC power outlet.

As the switch powers on, it begins the POST, a series of tests that runs automatically to ensure that the switch functions properly. LEDs can blink during the test. POST lasts approximately 1 minute. When the switch begins POST, the SYST, RPS, STAT, and SPEED LEDs turn green. The SYST LED blinks green, and the other LEDs remain solid green.

When the switch completes POST successfully, the SYST LED remains green. The RPS LED remains green for some time and then reflects the switch operating status. The other LEDs turn off and then reflect the switch operating status. If a switch fails POST, the SYST LED turns amber.

POST failures are usually fatal. Call Cisco technical support representative if your switch fails POST.

After a successful POST, unplug the power cord from the switch and install the switch in a rack, on a wall, on a table, or on a shelf.

If your configuration has an RPS, connect the switch and the RPS to different AC power sources. See the Cisco RPS documentation for information.



Note When you connect the RPS to the switch, put the RPS in standby mode. Set the RPS to active mode during normal operation.



Warning Attach only the following Cisco external power system to the switch: Cisco XPS 2200 Statement 387

Planning and Installing a Switch Stack (Optional)



Note This section applies only to the Catalyst 2960-X and 2960-XR stacking-capable switches.

Stack Guidelines

- Connect only Catalyst 2960-X or 2960-S switches in a mixed switch stack.



Note You can only create mixed stacks with Catalyst 2960-X or 2960-S switches (up to four switches). You cannot create mixed stacks with other switches. Catalyst 2960-XR switches cannot be added to mixed stacks. They can only stack with other Catalyst 2960-XR switches.

- Perform one of the following:
 - Install the FlexStack-Plus module and the FlexStack cable.
 - Install the FlexStack-Extended Fiber module and the fiber-optic cable.
 - Install the FlexStack-Extended Hybrid module and the required fiber-optic/FlexStack cables.



Note All the FlexStack modules are hot-swappable and can be inserted while the switch is powered on.

- Order the appropriate cable from your Cisco sales representative. The length of FlexStack cable depends on your configuration. These are the different sizes available:
 - CAB-STK-E-0.5M= (0.5-meter cable)
 - CAB-STK-E-1M= (1-meter cable)
 - CAB-STK-E-3M= (3-meter cable)
- Make sure that you have access to the switch rear panel and to the rear of the rack.

Installing a FlexStack-Plus or a FlexStack-Extended Module



Note The switch should always have a blank module installed when a FlexStack module is not used.

The Catalyst 2960X-48P-L switch is shown as an example. You can install the module in other switches as shown.

Procedure

- Step 1** Use a number 2 Phillips-head screwdriver to remove the FlexStack module blank cover on the switch back panel.

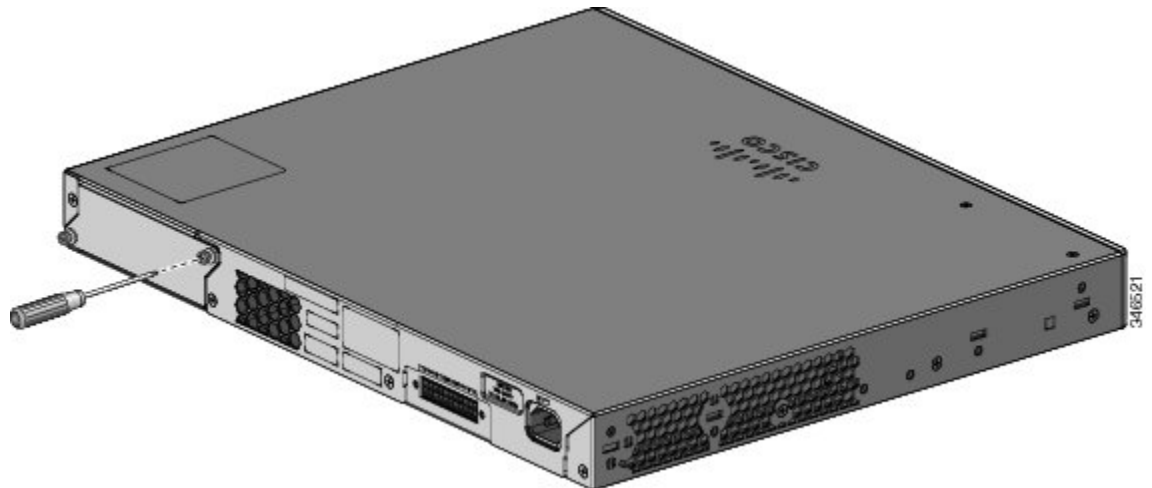

- Step 2** Grasp the FlexStack module on the sides, and insert it into the module slot. Push the module in completely until you feel it snap into place.
- The following example image uses FlexStack-Plus module.

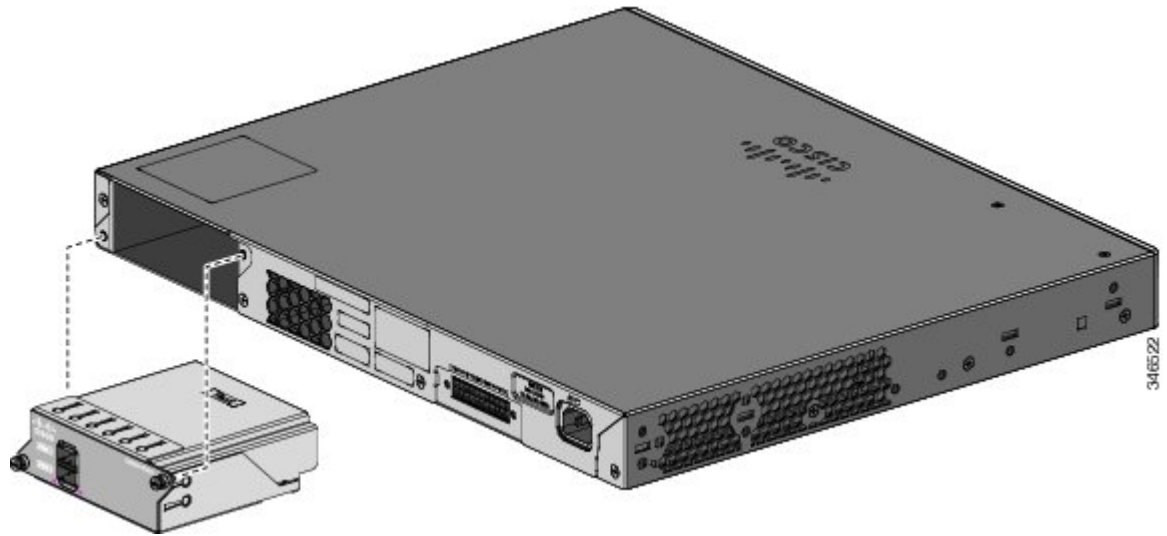

Step 3 Secure the screws on each side of the module.

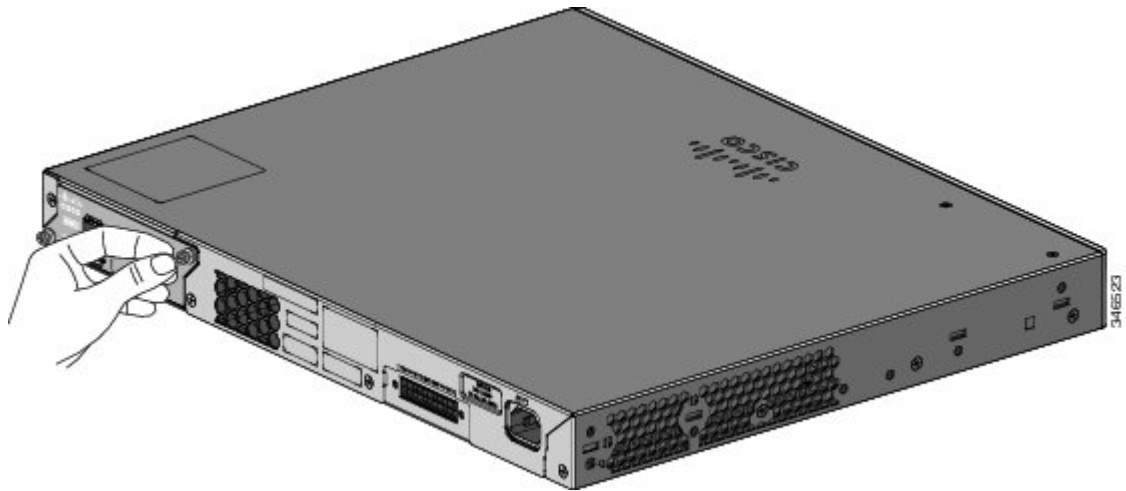

Note Avoid overtightening the screws.

Stack Cabling

Stacking using FlexStack-Plus Modules

Figure 1: Stacking Switches with the 0.5-meter FlexStack Cable

These figures show the switches stacked in a vertical rack or on a table. The connections are redundant. A Catalyst 2960-X switch is shown in the examples, the Catalyst 2960-XR switch can be stacked in the same way.

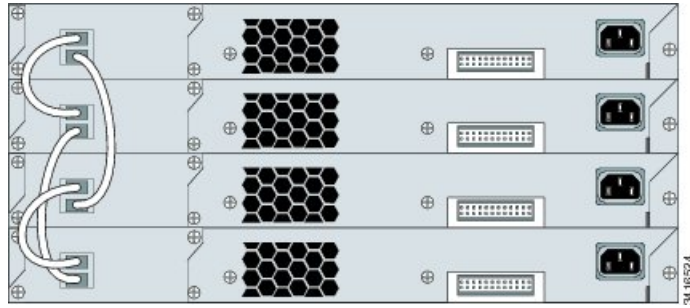
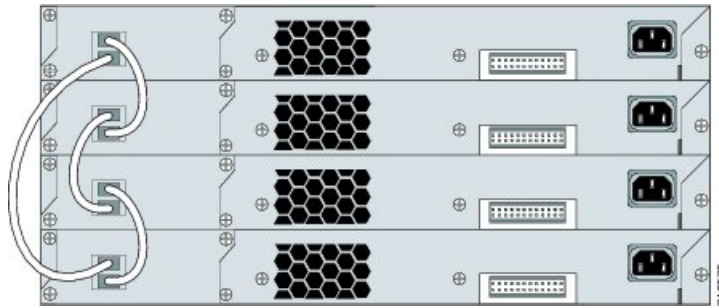

Figure 2: Stacking Switches with 0.5-meter and 3-meter FlexStack Cables



Stacking using FlexStack-Extended Modules

This section explains the supported stacking topologies using FlexStack-Extended Modules.

The following topology is created by stacking switches with FlexStack-Extended Fiber modules that are deployed across different floors of a building. The SFP+ module ports are connected using fiber cables.

Figure 3: Stacking with FlexStack-Extended Fiber Modules Across Floors of a Building

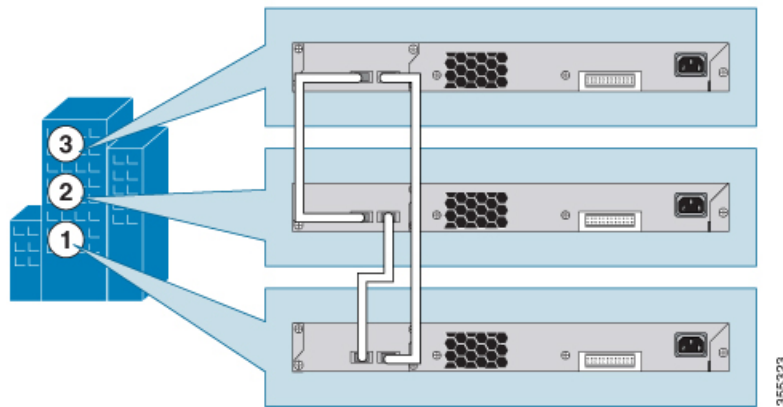

The following topology is created by stacking switches with FlexStack-Extended Fiber modules that are deployed across multiple buildings of a campus and different floors of a building.

Figure 4: Stacking with FlexStack-Extended Fiber Modules Across Floors and Buildings

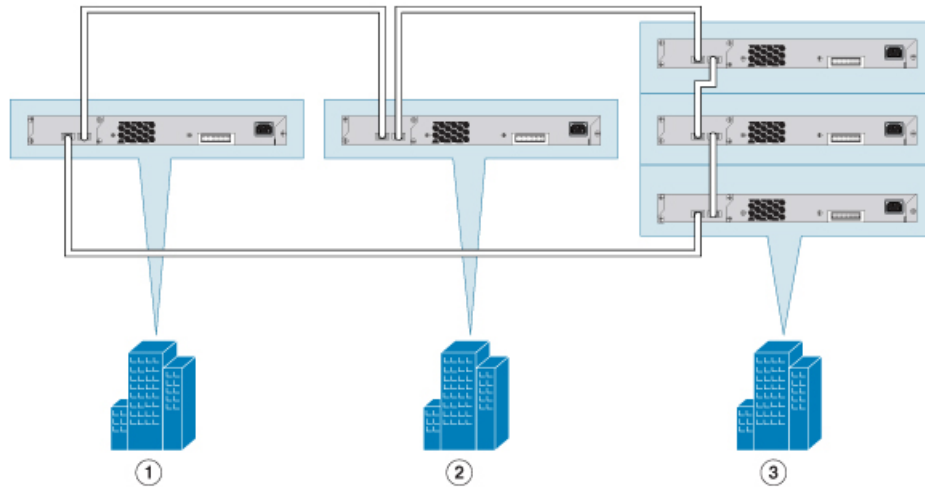

Using FlexStack-Extended Hybrid module, you can combine existing stack of switches and new switches spread across multiple wiring closets into one stack. To achieve this, the copper port on the FlexStack-Extended Hybrid module should be connected to the FlexStack-Plus port on a switch in your existing network. The fiber port on the Cisco FlexStack-Extended Fiber module can be used to connect switches over long distances. You can stack up to eight switches.

Figure 5: Extending Traditional FlexStack-Plus Stacks using FlexStack-Extended Modules

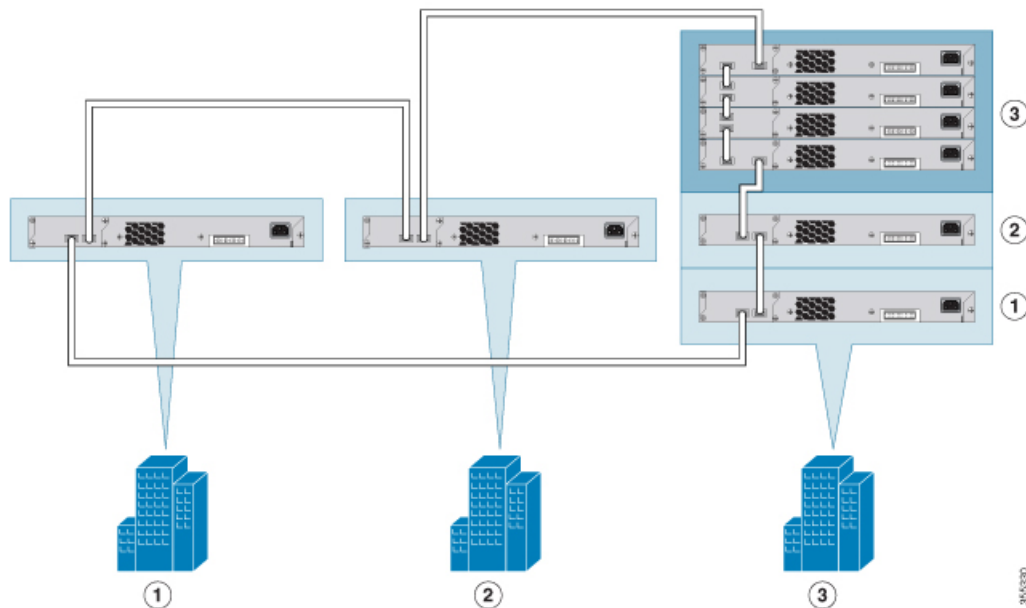

The following image shows a mixed stack network using FlexStack-Plus, FlexStack-Extended Fiber and Hybrid modules. This is one of the supported topologies using FlexStack modules. Typically, fiber modules are used to extend a network for long distance communication across buildings or floors in a building.

Figure 6: Mixed Stacking with FlexStack Modules

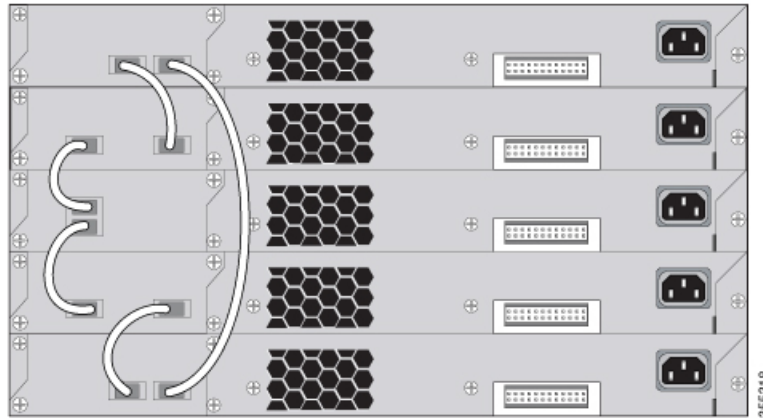

Stack Bandwidth and Partitioning Examples

Figure 7: Stack with Full Bandwidth Connections

This figure shows a stack that provides full bandwidth with redundant

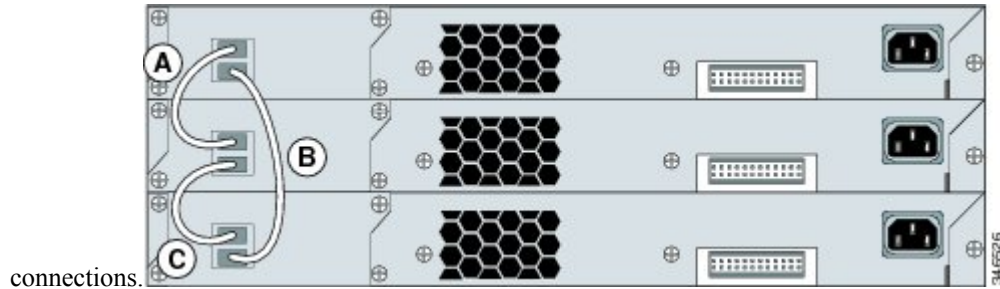

Figure 8: Stack with Half Bandwidth Connections

This figure shows a stack with incomplete stack cabling connections. This stack provides only half bandwidth and does not have redundant

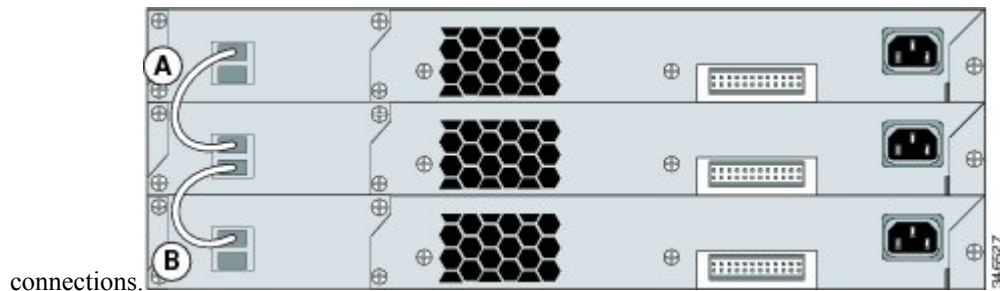

Figure 9: Stack with a Failover Condition

This figure shows a stack with a bad FlexStack cable in link B. This stack provides only half bandwidth and does not have redundant connections.

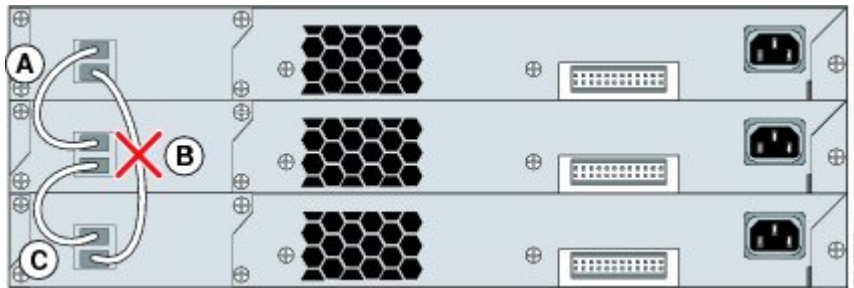
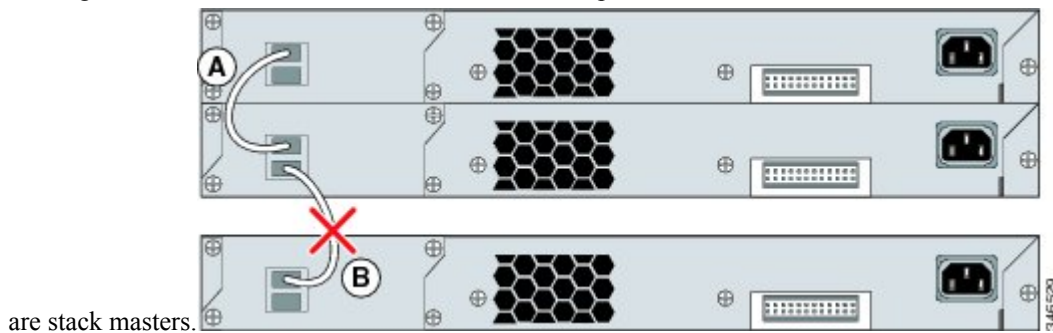

Figure 10: Partitioned Stack with a Failover Condition

This figure shows a stack with a bad link B. This stack partitions into two stacks, and switch 1 and switch 3



are stack masters.

Power-On Sequence for Switch Stacks

Consider these guidelines before you power on the switches in a stack:

- The sequence in which the switches are first powered on might affect the switch that becomes the stack master.
- If you want a particular switch to be the stack master, power on that switch first. This switch becomes the stack master and remains the stack master until a master reelection. After 2 minutes, power on the other stack switches.
- If you have no preference as to which switch becomes the stack master, power on all the switches in the stack within a 1-minute timeframe. These switches participate in the stack master election. Switches powered on after the 1-minute timeframe do not participate in the election.
- Power off a switch before you add it to or remove it from an existing switch stack.

For conditions that can cause a stack master reelection or to manually elect the stack master, see the *Catalyst 2960-X Switch Stacking Configuration Guide* or *Catalyst 2960-XR Switch Stacking Configuration Guide* on Cisco.com.

Installing the Switch

Rack-Mounting

Installation in other than 19-inch racks requires a bracket kit not included with the switch.

**Warning**

To prevent bodily injury when mounting or servicing this unit in a rack, you must take special precautions to ensure that the system remains stable. The following guidelines are provided to ensure your safety:

- This unit should be mounted at the bottom of the rack if it is the only unit in the rack.
- When mounting this unit in a partially filled rack, load the rack from the bottom to the top with the heaviest component at the bottom of the rack.
- If the rack is provided with stabilizing devices, install the stabilizers before mounting or servicing the unit in the rack.

Statement 1006

Figure 11: Rack-Mounting Brackets

This figure shows the standard 19-inch brackets and other optional mounting brackets. You can order the optional brackets from your Cisco sales

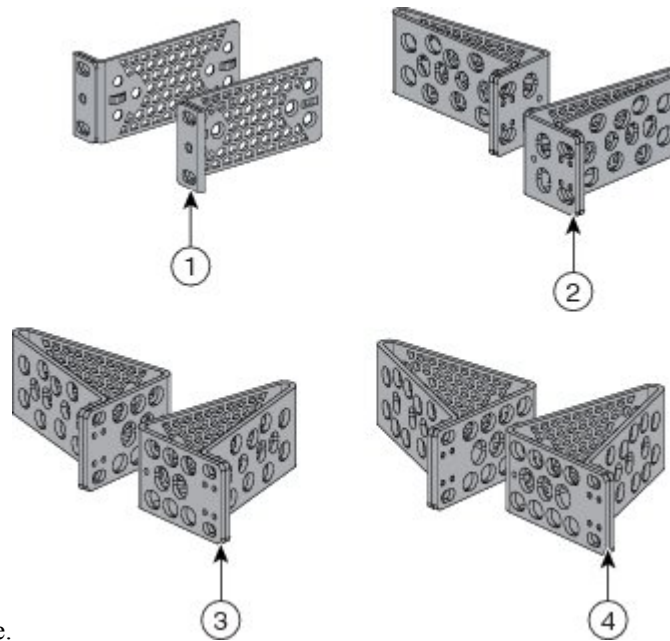

representative.

1	19-inch brackets	3	23-inch brackets
2	ETSI brackets	4	24-inch brackets

Attaching the Rack-Mount Brackets for the Catalyst 2960-X Switches

Procedure

Use two Phillips flat-head screws to attach the long side of the bracket to each side of the switch.

Figure 12: Attaching Brackets for 19-inch Racks

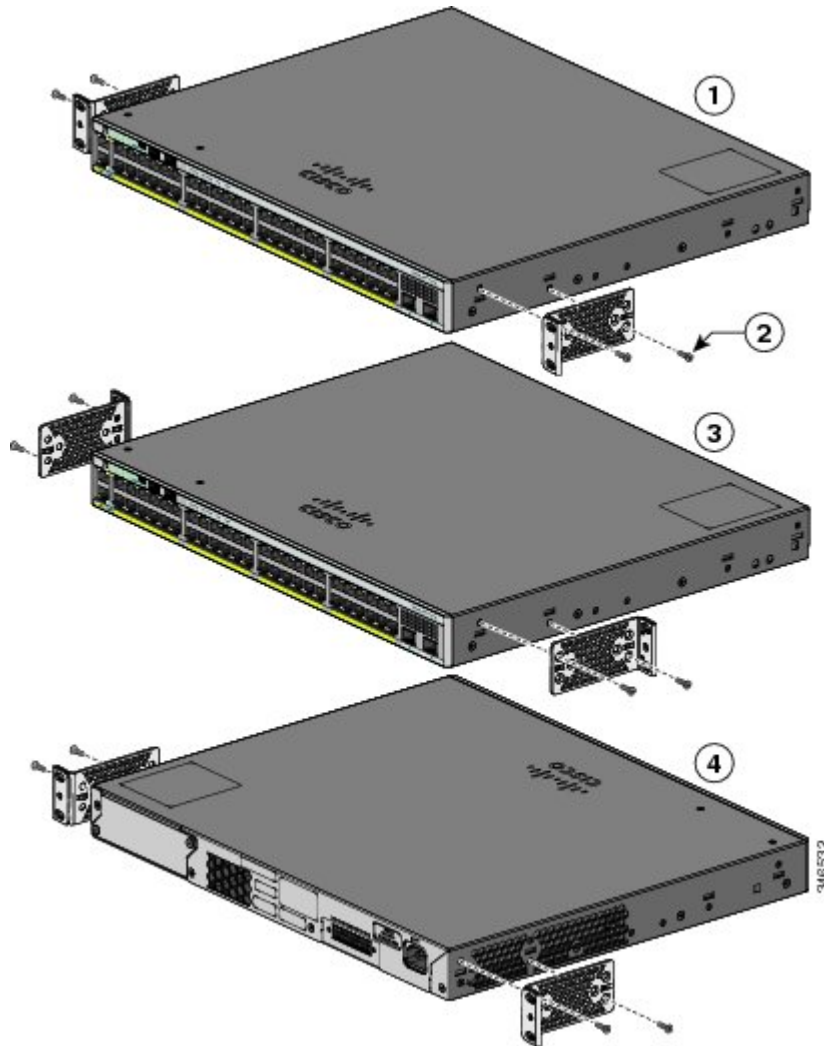

1	Front-mounting position	3	Mid-mounting position
2	Number-8 Phillips flat-head screws (48-2927-01)	4	Rear-mounting position

Attaching the Rack-Mount Brackets for the Catalyst 2960-XR Switches

Procedure

Use four Phillips flat-head screws to attach the long side of the bracket to each side of the switch.

Figure 13: Attaching Brackets for 19-inch Racks

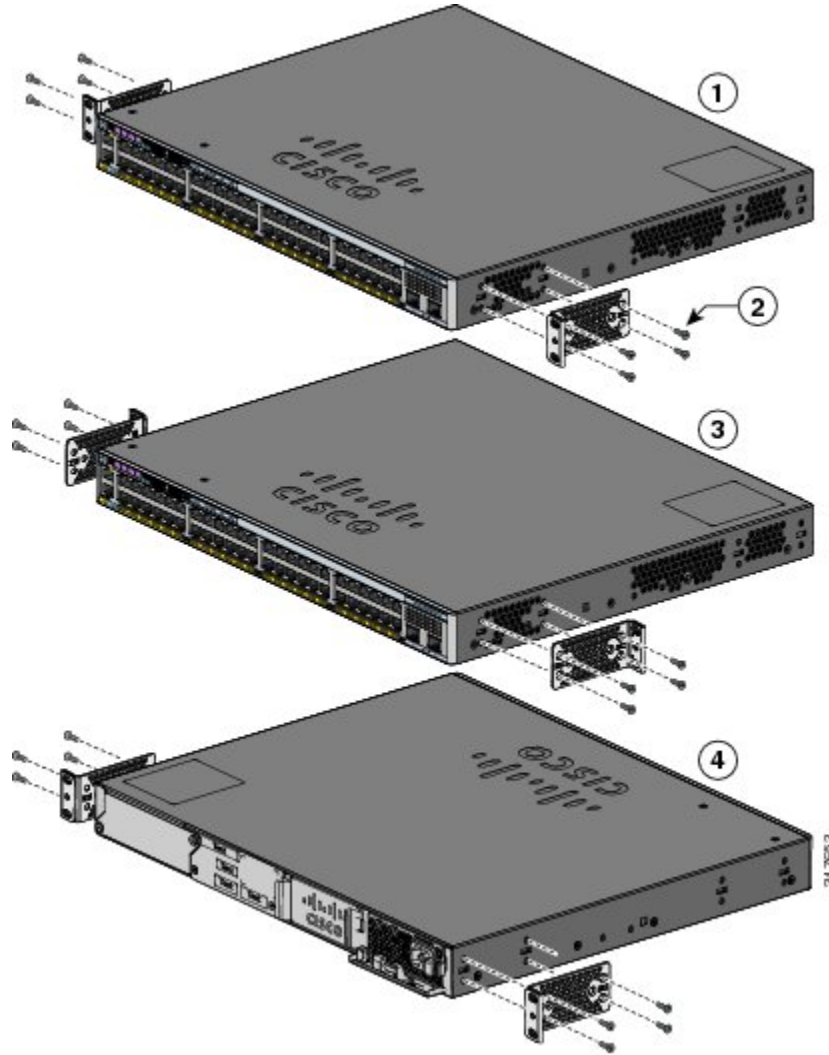

1	Front-mounting position	3	Mid-mounting position
2	Number-8 Phillips flat-head screws (48-2927-01)	4	Rear-mounting position

Mounting in a Rack

Procedure

- Step 1** Use the four supplied Phillips machine screws to attach the brackets to the rack.

Step 2 Use the black Phillips machine screw to attach the cable guide to the left or right bracket.

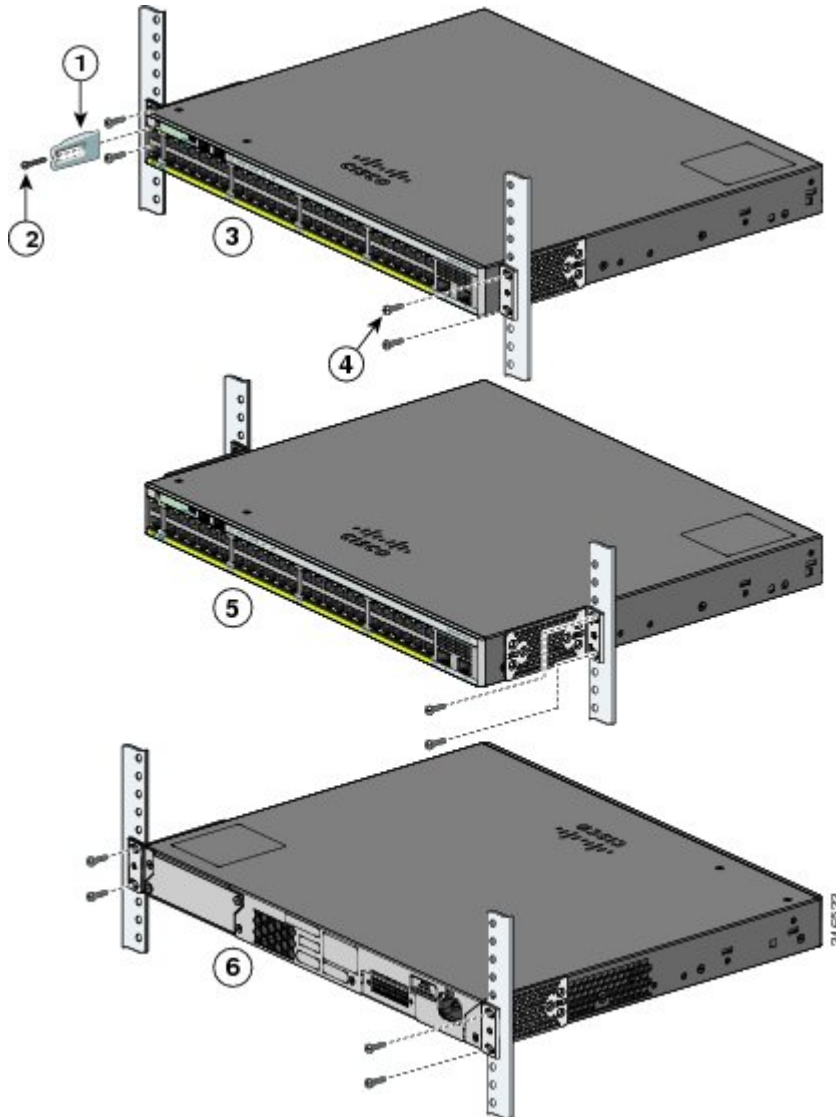

1	Cable guide	4	Number-12 Phillips pan-head screws (48-0523-01) or Number-10 Phillips pan-head screws (48-0627-01)
2	Phillips machine screw, black (48-0654-01)	5	Mid-mounting position
3	Front-mounting position	6	Rear-mounting position

Wall-Mounting



Warning Read the wall-mounting instructions carefully before beginning installation. Failure to use the correct hardware or to follow the correct procedures could result in a hazardous situation to people and damage to the system. Statement 378

Attaching the Brackets for Wall-Mounting

Procedure

- Step 1** Attach a 19-inch bracket to one side of the switch.
Step 2 Follow the same steps to attach the second bracket to the opposite side.

Figure 14: Attaching the 19-inch Brackets for Wall-Mounting

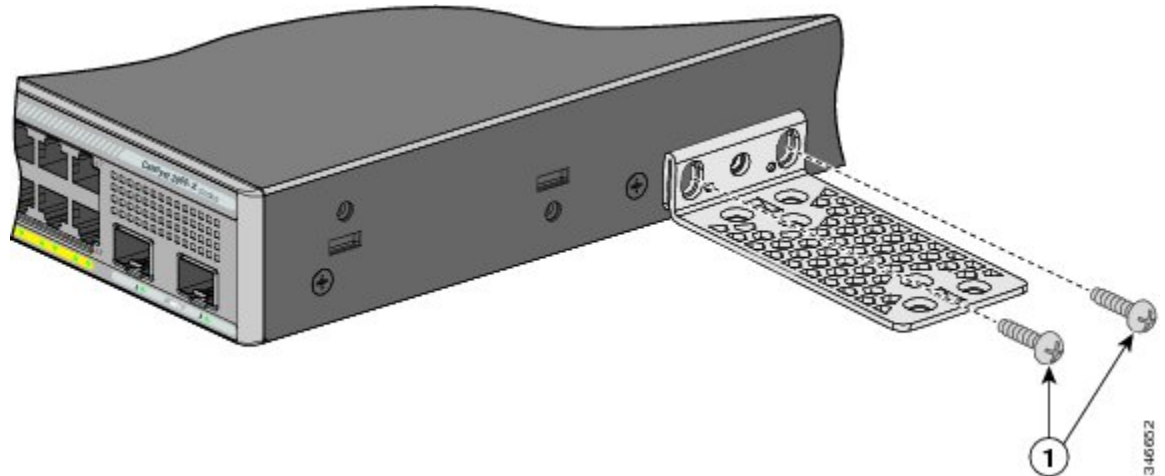

1

Number-8 phillips flat-head screws (48-2927-01)

Mounting on a Wall

For the best support of the switch and cables, make sure that the switch is attached securely to wall studs or to a firmly attached plywood-mounting backboard. Mount the switch with the front panel facing down.



Warning Read the wall-mounting instructions carefully before beginning installation. Failure to use the correct hardware or to follow the correct procedures could result in a hazardous situation to people and damage to the system. Statement 378



Caution Following safety regulations, wall-mount the switch with its front panel facing down.

Figure 15: Mounting on a Wall

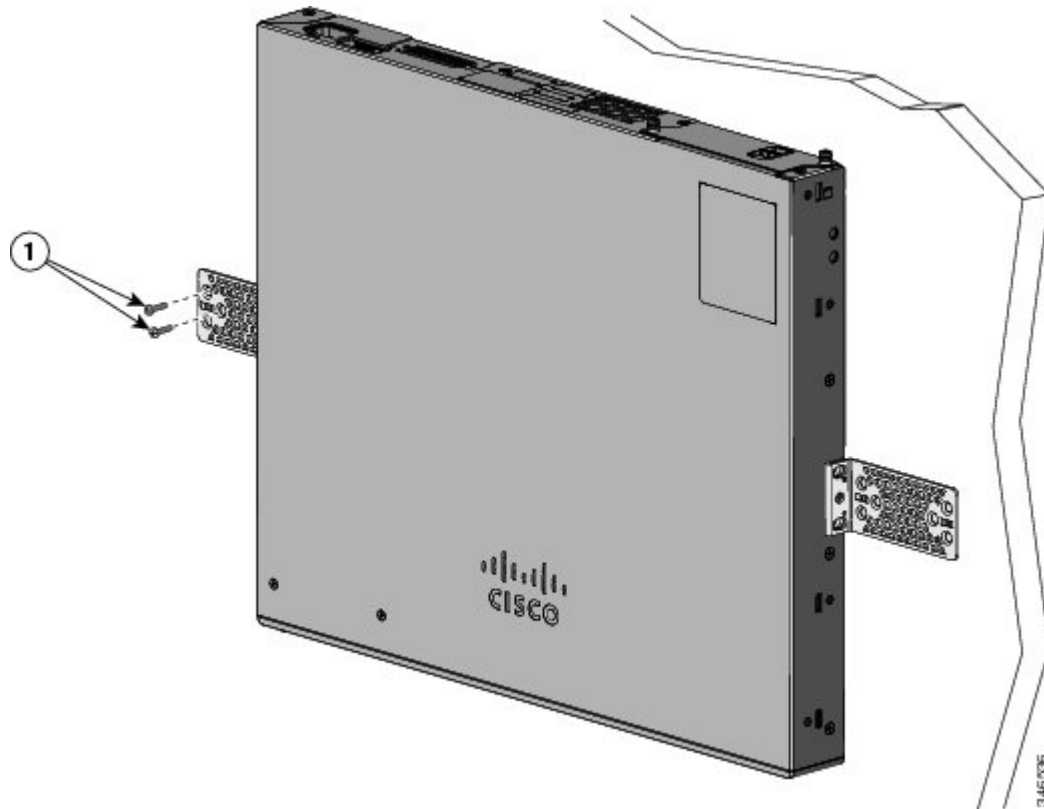

1

User-supplied screws (for example, you can use # 6 wood screws with a washer head 1-inch long).

When you complete the switch installation, see [After Switch Installation, on page 19](#) for information on switch configuration.

Installing the Switch on a Table or Shelf

Procedure

- Step 1** To install the switch on a table or shelf, locate the adhesive strip with the rubber feet in the mounting-kit envelope.
- Step 2** Attach the four rubber feet to the four circular etches on the bottom of the chassis.
- Step 3** Place the switch on the table or shelf near an AC power source.

- Step 4** When you complete the switch installation, see [After Switch Installation, on page 19](#) for information on switch configuration.
-

After Switch Installation

- Configure the switch by running Express Setup to enter the initial switch configuration. See the switch getting started guide on Cisco.com.
- Use the CLI setup program to enter the initial switch configuration.
- Install the power cord retainer (optional).
- Connect to the front-panel ports.

Related Topics

- [Connecting FlexStack-Plus modules \(Optional\)](#), on page 19
- [Installing the Power Cord Retainer \(Optional\)](#), on page 22
- [Installing an SFP or SFP+ Module](#), on page 25
- [10/100/1000 PoE and PoE+Port Connections](#), on page 28

Connecting FlexStack modules

Connecting FlexStack-Plus modules (Optional)

Always use a Cisco-approved FlexStack cable to connect the switches.



Note This is only supported on the stack-capable switches.



Caution Use only approved cables, and connect only to other Catalyst 2960-X or 2960-S switches. Equipment might be damaged if connected to other nonapproved Cisco cables or equipment.

Procedure

- Step 1** Remove the dust covers from the FlexStack cables, and store them for future use.
- Step 2** Insert one end of the FlexStack cable into the stack port of the first switch. Insert the other end of the cable into the stack port on the other switch. Make sure that you insert the cables in completely until you feel them snap into place.

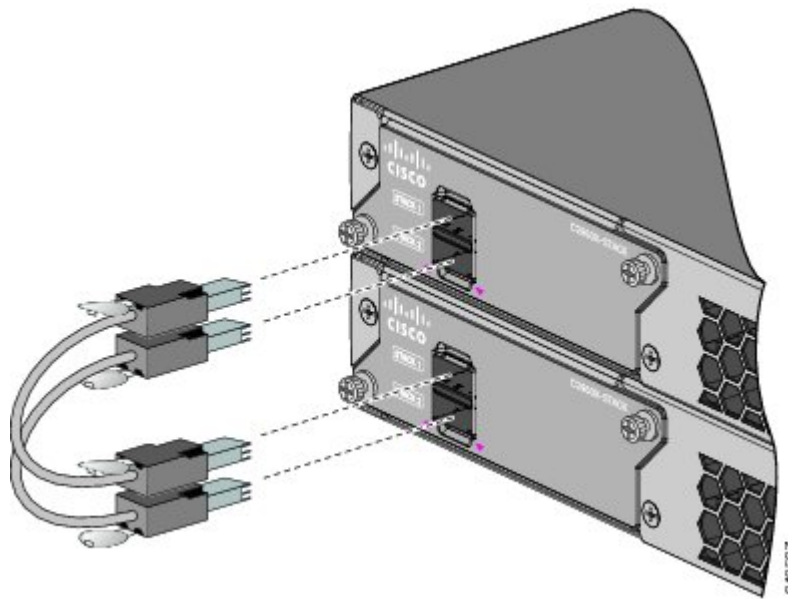

Note When you connect the FlexStack cable to the STACK 1 port, the tab should be above the connector. When you connect the FlexStack cable to the STACK 2 port, the tab should be below the connector.

Step 3 Replace the dust covers when you remove the FlexStack cables from the connectors.

Caution Removing and installing the FlexStack cable can shorten its useful life. Do not remove and insert the cable more often than is absolutely necessary.

Connecting FlexStack-Extended modules (Optional)

Always use a Cisco-approved FlexStack cable to connect the switches.



Note This is only supported on the stack-capable switches.

Procedure

Step 1 Remove the dust covers from the FlexStack cables, and store them for future use.

Step 2 Do one of the following:

- To connect two FlexStack-Extended Fiber modules, insert one end of the FlexStack cable into the SFP+ module port of the first switch and the other end of the cable into the SFP+ module port on the other switch.
- To connect two FlexStack-Extended Hybrid modules, insert the FlexStack-Plus cable connectors into the copper FlexStack-Plus ports and the fiber module connectors into the SFP+ module ports on the switches.

For information on installing an SFP+ module, see [Installing an SFP or SFP+ Module, on page 25](#). Make sure that you insert the cables in completely until you feel them snap into place.

Figure 16: Connecting Two FlexStack-Extended Fiber Modules

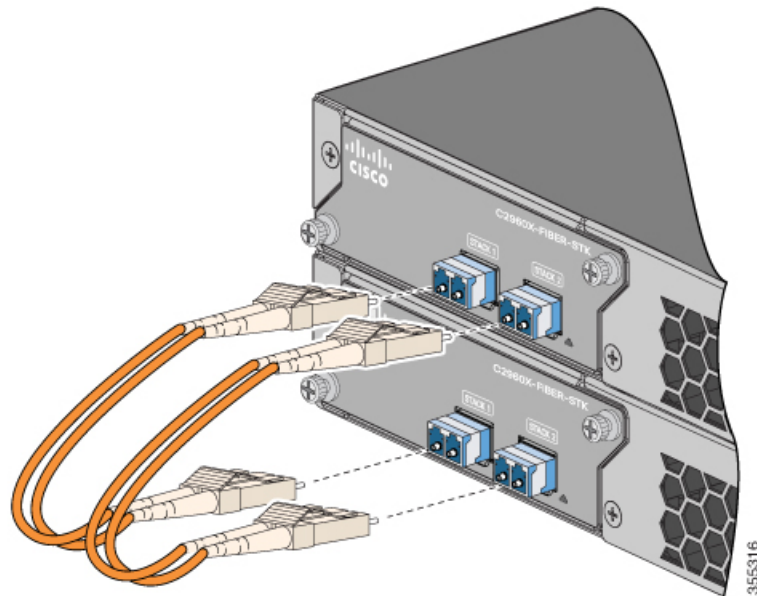
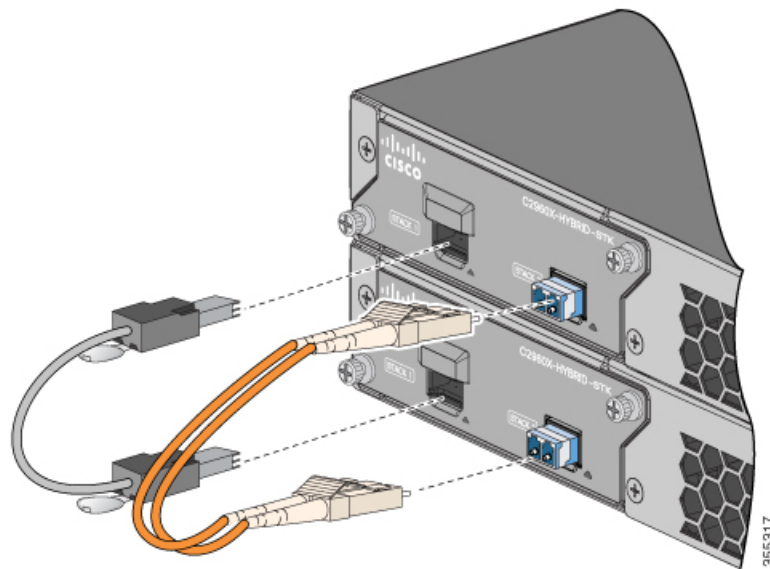

Figure 17: Connecting Two FlexStack-Extended Hybrid Modules



Note When you connect the FlexStack cable to the STACK 1 ports on switches, ensure that the tabs are below the connectors.

Step 3 Replace the dust covers when you remove the FlexStack cables from the connectors.

Caution Removing and installing the FlexStack cable can shorten its useful life. Do not remove and insert the cable more often than is absolutely necessary.

Removing a FlexStack Cable

Procedure

- Step 1** To remove a FlexStack cable, grasp the tab on the cable connector and gently pull straight out.
- Step 2** When you remove the FlexStack cables from the connectors, replace the dust covers to protect them from dust.
- Caution** Removing and installing the FlexStack cable can shorten its useful life. Do not remove and insert the cable more often than is absolutely necessary.
-

Installing the Power Cord Retainer (Optional)



Note This section applies only to the Catalyst 2960-X switches.

The power cord retainer is optional (part number [PWR-CLP=]). You can order it when you order your switch, or you can order it later from your Cisco representative.

Procedure

- Step 1** Choose the sleeve size of the power cord retainer based on the thickness of the cord. The smaller sleeve can be snapped off and used for thin cords.
- Step 2** Slide the retainer around the AC power cord, and pass it around the loop on the switch.

Figure 18: Inserting the Retainer Through the Lanced Loop

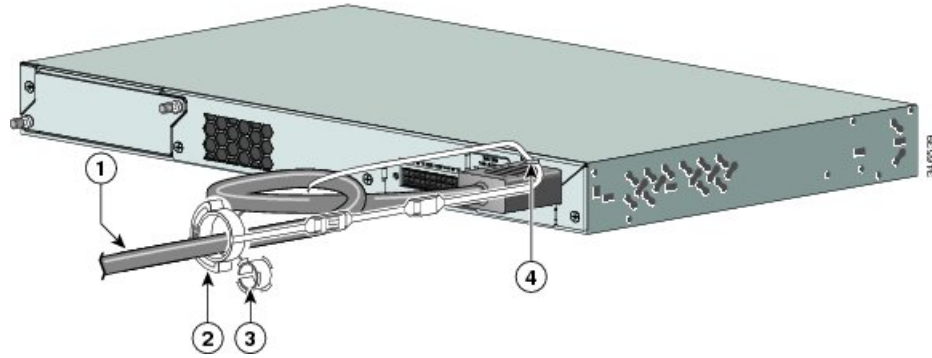

1	AC power cord	3	Sleeve for thinner power cords
2	Power cord retainer	4	Loop

Step 3 Slide the retainer through the first latch.

Figure 19: Sliding the Retainer Through the Latch

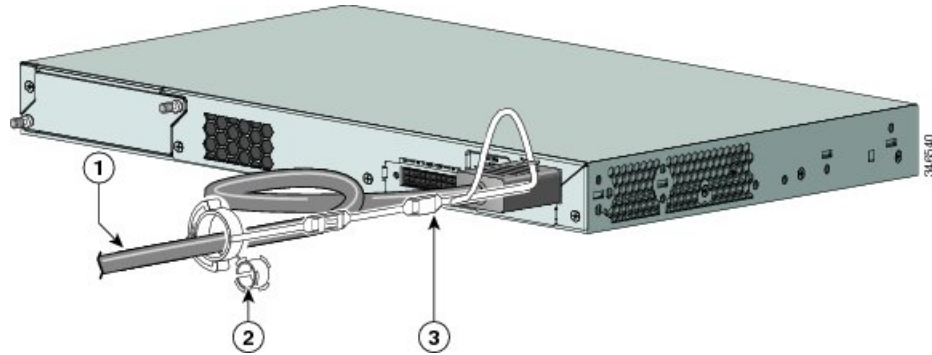

1	AC power cord	3	Latch
2	Smaller sleeve for thin power cords		

Step 4 Slide the retainer through the other latches to lock it.

Figure 20: Locking the Retainer

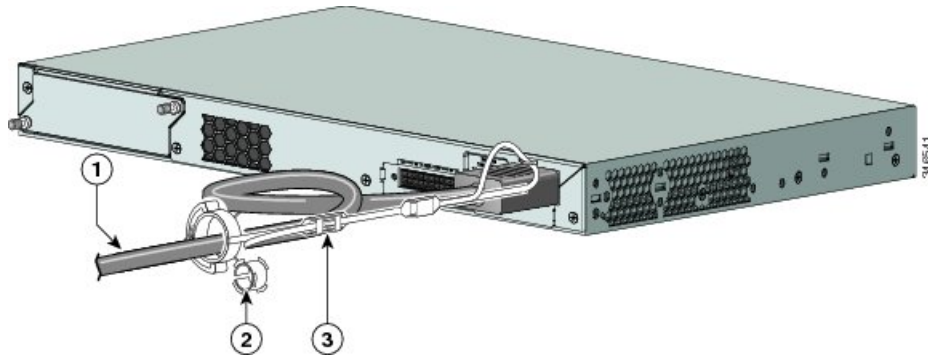

1	AC power cord	3	Latches
2	Sleeve for thin power cords		

Step 5 (Optional) Use the small sleeve for thin power cords. Use the small sleeve to provide greater stability for thin cords. Detach the sleeve, and slide it over the power cord.

Figure 21: Sleeve Around the Power Cord

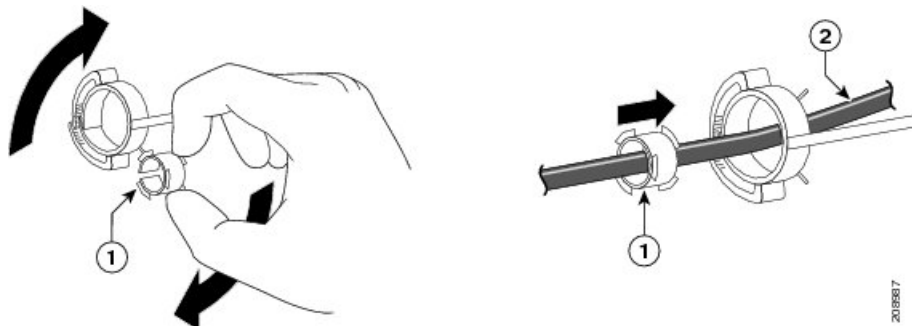

1	Sleeve for thin power cords	2	AC power cord
---	-----------------------------	---	---------------

Step 6 Secure the AC power cord by pressing on the retainer.

Figure 22: Securing the Power Cord in the Retainer

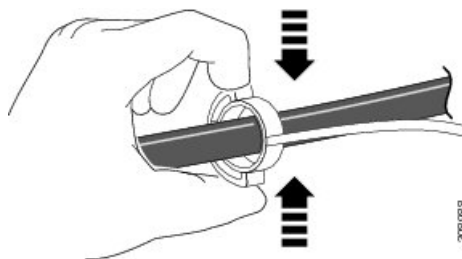

Installing SFP Modules

Related Topics

[SFP and SFP+ Module Slots](#)

Installing an SFP or SFP+ Module

Before you begin

When installing SFP or SFP+ modules, observe these guidelines:

- Do not remove the dust plugs from the modules or the rubber caps from the fiber-optic cable until you are ready to connect the cable. The plugs and caps protect the module ports and cables from contamination and ambient light.
- To prevent ESD damage, follow your normal board and component handling procedures when connecting cables to the switch and other devices.



Caution Removing and installing an SFP or SFP+ module can shorten its useful life. Do not remove and insert any module more often than is absolutely necessary.

Procedure

- Step 1** Attach an ESD-preventive wrist strap to your wrist and to a bare metal surface.
- Step 2** Find the send (TX) and receive (RX) markings on the module top.
- On some SFP or SFP+ modules, the send and receive (TX and RX) markings might be replaced by arrows that show the direction of the connection.
- Step 3** If the module has a bale-clasp latch, move it to the open, unlocked position.
- Step 4** Align the module in front of the slot opening, and push until you feel the connector snap into place.
- Step 5** If the module has a bale-clasp latch, close it.
- Step 6** For fiber-optic SFP or SFP+ modules, remove the dust plugs and save.
- Step 7** Connect the SFP cables.

Figure 23: Installing an SFP Module



Removing an SFP Module

Connecting to SFP and SFP+ Modules

Related Topics

[SFP and SFP+ Module Slots](#)

Connecting to Fiber-Optic SFP and SFP+ Modules



Warning Class 1 laser product. Statement 1008



Caution Do not remove the rubber plugs from the SFP or SFP+ module port or the rubber caps from the fiber-optic cable until you are ready to connect the cable. The plugs and caps protect the SFP module ports and cables from contamination and ambient light. Before connecting to the SFP module, be sure that you understand the port and cabling stipulations.

Procedure

- Step 1** Remove the rubber plugs from the module port and fiber-optic cable, and store them for future use.
- Step 2** Insert one end of the fiber-optic cable into the SFP or SFP+ module port.
- Step 3** Insert the other cable end into a fiber-optic receptacle on a target device.

Figure 24: Connecting to a Fiber-Optic SFP Module Port

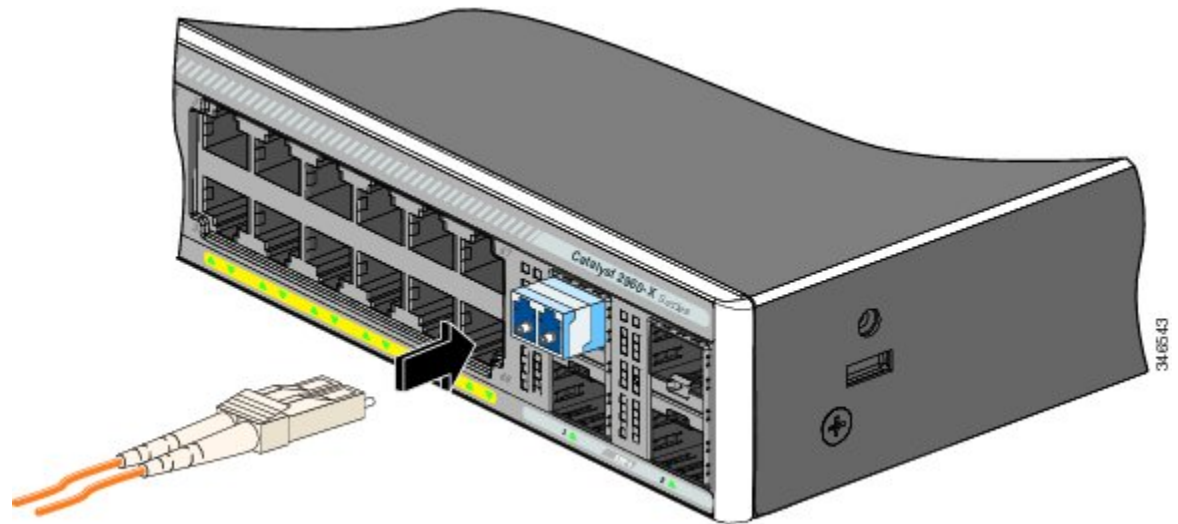

Step 4 Observe the port status LED.

The LED turns green when the switch and the target device have an established link.

The LED turns amber while the STP discovers the network topology and searches for loops. This process takes about 30 seconds, and then the port LED turns green.

If the LED is off, the target device might not be turned on, there might be a cable problem, or there might be problem with the adapter installed in the target device.

Related Topics

[SFP Module Connectors](#)

Connecting to 1000BASE-T SFP

When connecting to a 1000BASE-T device, be sure to use a four twisted-pair, Category 5 or higher cable.



Note The automatic medium-dependent interface crossover (auto-MDIX) feature is enabled by default. For configuration information for this feature, see the switch software configuration guide or the switch command reference on Cisco.com.



Caution To prevent ESD damage, follow your normal board and component handling procedures.

Procedure

- Step 1** Connect one end of the cable to the SFP module port. Insert a four twisted-pair, straight-through cable when you connect to servers, workstations, and routers. Insert a four twisted-pair, crossover cable when you connect to switches or repeaters.
- Step 2** Connect the other end of the cable to an RJ-45 connector on the other device.

Figure 25: Connecting to a 1000BASE-T SFP Module

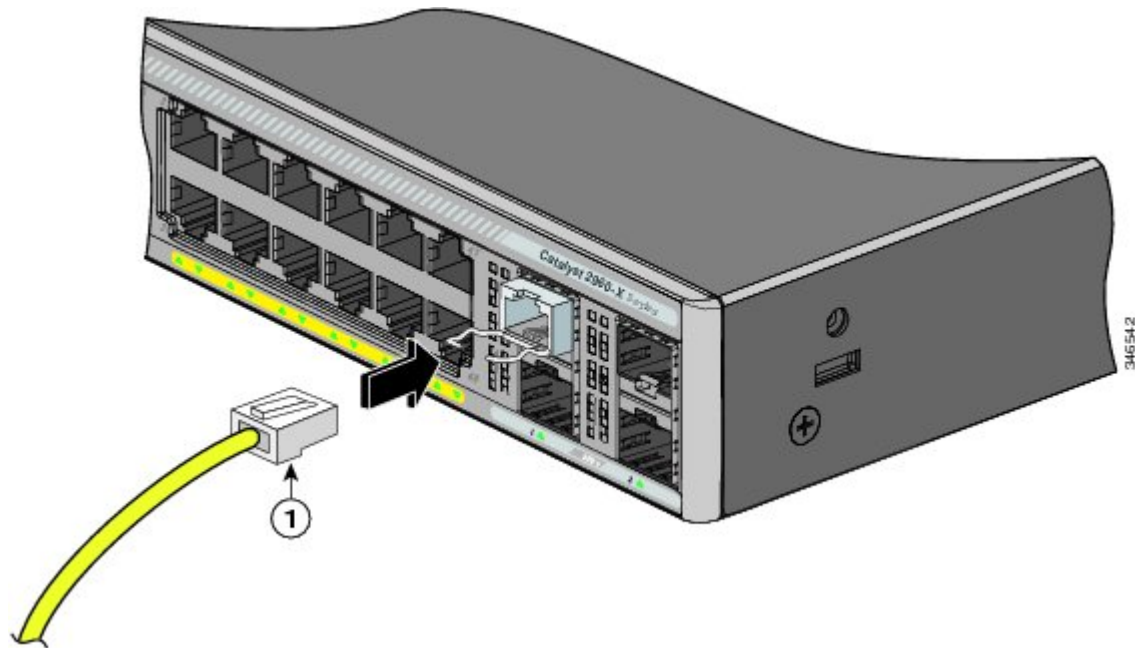

1	RJ-45 connector
---	-----------------

- Step 3** Observe the port status LED.
- The LED turns green when the switch and the other device have an established link.
 - The LED turns amber while the STP discovers the network topology and searches for loops. This process takes about 30 seconds, and then the port LED turns green.
 - If the LED is off, the other device might not be turned on, there might be a cable problem, or there might be a problem with the adapter in the other device.
- Step 4** If necessary, reconfigure and restart the switch or other device.

10/100/1000 PoE and PoE+Port Connections

The ports provide PoE support for devices compliant with IEEE 802.3af and 802.3at (PoE+), and also provide Cisco prestandard PoE support for Cisco IP Phones and Cisco Aironet Access Points.

On a per-port basis, you can control whether or not a port automatically provides power when an IP phone or an access point is connected.

To access an advanced PoE planning tool, use the Cisco Power Calculator available on Cisco.com at this URL: <http://tools.cisco.com/cpc/launch.jsp>

You can use this application to calculate the power supply requirements for a specific PoE configuration. The results show output current, output power, and system heat dissipation.

**Warning**

Voltages that present a shock hazard may exist on Power over Ethernet (PoE) circuits if interconnections are made using uninsulated exposed metal contacts, conductors, or terminals. Avoid using such interconnection methods, unless the exposed metal parts are located within a restricted access location and users and service people who are authorized within the restricted access location are made aware of the hazard. A restricted access area can be accessed only through the use of a special tool, lock and key or other means of security. Statement 1072

**Caution**

Category 5e and Category 6 cables can store high levels of static electricity. Always ground the cables to a suitable and safe earth ground before connecting them to the switch or other devices.

**Caution**

Noncompliant cabling or powered devices can cause a PoE port fault. Use only standard-compliant cabling to connect Cisco prestandard IP Phones and wireless access points, IEEE 802.3af, or 802.3at (PoE+) compliant devices. You must remove any cable or device that causes a PoE fault.

Procedure

Step 1 Connect one end of the cable to the switch PoE port.

Step 2 Connect the other end of the cable to an RJ-45 connector on the other device. The port LED turns on when both devices have established link.

The port LED is amber while STP discovers the topology and searches for loops. This process takes about 30 seconds, and then the port LED turns green. If the LED is off, the other device might not be turned on, there might be a cable problem, or there might be a problem with the adapter in the other device.

Step 3 Reconfigure and reboot the connected device, if needed.

Step 4 Repeat Steps 1 through 3 to connect each device.

Note Many legacy powered devices, including older Cisco IP phones and access points that do not fully support IEEE 802.3af, might not support PoE when connected to the switches by a crossover cable.

10/100/1000 Port Connections

The switch 10/100/1000 port configuration changes to operate at the speed of the attached device. If the attached ports do not support autonegotiation, you can manually set the speed and duplex parameters. Connecting devices that do not autonegotiate or that have the speed and duplex parameters manually set can reduce performance or result in no linkage.

To maximize performance, choose one of these methods for configuring the Ethernet ports:

- Let the ports autonegotiate both speed and duplex.
- Set the interface speed and duplex parameters on both ends of the connection.

Auto-MDIX Connections

The autonegotiation and the auto-MDIX features are enabled by default on the switch.

With autonegotiation, the switch port configurations change to operate at the speed of the attached device. If the attached device does not support autonegotiation, you can manually set the switch interface speed and duplex parameters.

With auto-MDIX, the switch detects the required cable type for copper Ethernet connections and configures the interface accordingly.

If auto-MDIX is disabled, use the guidelines in this table to select the correct cable.

Table 1: Recommended Ethernet Cables (When Auto-MDIX is Disabled)

Device	Crossover Cable	Straight-Through Cable
Switch to switch	Yes	No
Switch to hub	Yes	No
Switch to computer or server	No	Yes
Switch to router	No	Yes
Switch to IP phone	No	Yes

¹ 100BASE-TX and 1000BASE-T traffic requires twisted four-pair, Category 5 or higher. 10BASE-T traffic can use Category 3 cable or higher.

Where to Go Next

If the default configuration is satisfactory, the switch does not need further configuration. You can use any of these management options to change the default configuration:

- Start the Network Assistant application, which is described in the getting started guide. Through this GUI, you can configure and monitor a switch cluster or an individual switch.
- Use the CLI to configure the switch as a member of a cluster or as an individual switch from the console.

- Use the Cisco Prime Infrastructure application.
- If you are using Cisco IOS XE Denali 16.1.x and later releases, see the *Configuring the Switch* chapter in this guide for information about setting up the switch.

