

Cisco UCS C240 M7 SFF Rack Server

A printed version of this document is only a copy and not necessarily the latest version. Refer to the following link for the latest released version:

<https://www.cisco.com/c/en/us/products/servers-unified-computing/ucs-c-series-rack-servers/datasheet-listing.html>



CONTENTS

OVERVIEW	2
DETAILED VIEWS	4
Chassis Front View - Option 1	4
Chassis Rear View	5
Chassis Front View - Option 2	7
Chassis Rear View - Option 2	8
BASE SERVER STANDARD CAPABILITIES and FEATURES	10
CONFIGURING the SERVER	13
STEP 1 SELECT SERVER SKU	14
STEP 2 SELECT RISER CARDS (REQUIRED)	15
STEP 3 SELECT CPU(s) (REQUIRED)	17
STEP 4 SELECT MEMORY (REQUIRED)	21
Memory configurations and mixing rules	24
STEP 5 SELECT DRIVE CONTROLLERS (OPTIONAL)	26
RAID Volumes and Groups	26
STEP 6 SELECT DRIVES (OPTIONAL)	30
STEP 7 SELECT PCIe CARD(s) (OPTIONAL)	35
ORDER OPTIONAL PCIe OPTION CARD ACCESSORIES	37
STEP 8 ORDER GPU CARDS (OPTIONAL)	38
STEP 9 ORDER POWER SUPPLY (REQUIRED)	41
STEP 10 SELECT INPUT POWER CORD(s) (REQUIRED)	42
STEP 11 ORDER TOOL-LESS RAIL KIT (REQUIRED) AND REVERSIBLE CABLE MANAGEMENT ARM (OPTIONAL)	46
STEP 12 SELECT MANAGEMENT CONFIGURATION (OPTIONAL)	47
STEP 13 ORDER SECURITY DEVICES (REQUIRED)	48
STEP 14 SELECT LOCKING SECURITY BEZEL (OPTIONAL)	49
STEP 15 ORDER M.2 SATA SSDs (OPTIONAL)	50
STEP 16 SELECT OPERATING SYSTEM AND VALUE-ADDED SOFTWARE	51
STEP 17 CHOOSE OPTIONAL OPERATING SYSTEM MEDIA KIT	54
SUPPLEMENTAL MATERIAL	55
Block Diagram	55
	56
Chassis	57
Risers	59
Riser Card Configurations and Options	61
Serial Port Details	69
KVM Cable	69
UPGRADING or REPLACING CPUs and Memory	70
SPARE PARTS	71
TECHNICAL SPECIFICATIONS	86
Dimensions and Weight	86
Power Specifications	88
Environmental Specifications	92
Extended Operating Temperature Hardware Configuration Limits	93
Compliance Requirements	94

OVERVIEW

The Cisco UCS C240 M7 SFF server extends the capabilities of Cisco's Unified Computing System portfolio in a 2U form factor with the addition of the 4th Gen Intel® Xeon® Scalable Processors (codenamed Sapphire Rapids), 16 DIMM slots per CPU for DDR5-4800 DIMMs with DIMM capacity points up to 256GB.

The Cisco UCS C240 M7 SFF server harnesses the power of the latest 4th Gen Intel® Xeon® Scalable Processors (codenamed Sapphire Rapids), and offers the following:

CPU: Up to 2x 4th Gen Intel® Xeon® Scalable Processors (codenamed Sapphire Rapids) with up to 60 cores per processor.

Memory: Up to 8TB with 32 x 256GB DDR5-4800 DIMMs, in a 2-socket configuration.

The server provides one or two internal slot for one of the following:

- Cisco 24G Tri-mode RAID controller¹ with cache backup to control SAS/SATA/NVMe drives or
- Cisco 12G RAID controller with cache backup to control SAS/SATA drives or
- Cisco 12G SAS pass-through HBA to control SAS/SATA drives

mLOM: The UCS C240 M7 SFF server has a single 1GBE management port. A modular LAN on motherboard (mLOM)/OCP 3.0 module provides up to two 100GBE ports. A connector on the front of the chassis provides KVM functionality.

There are several options to choose from:

- **Option 1 UCSC-C240-M7SX** (see [Figure 1 on page 3](#)):
 - Up to 24 front facing SFF SAS/SATA HDDs or SAS/SATA SSDs or NVMe SSDs (optionally up to 4 of the slots can be direct-attach NVMe)
 - I/O-centric option provides up to 8 PCIe slots using all three rear risers
 - Storage-centric option provides three rear risers with a total of up to 4 SFF drives slot (SAS/SATA or NVMe PCIe Gen4) and 3 PCIe slots or
- **Option 2 UCSC-C240-M7SN** (see [Figure 1 on page 3](#)):
 - Up to 24 front facing SFF NVMe SSDs (drives are direct-attach to PCIe Gen4 x2)
 - I/O-centric option provides up to 8 PCIe slots using all three rear risers
 - Storage-centric option provides three rear risers with a total of up to 4 SFF drives slot (NVMe PCIe Gen4) and 3 PCIe slots.

The Cisco UCS C240 M7 SFF server can be used standalone, or as part of the Cisco Unified Computing System, which unifies computing, networking, management, virtualization, and storage access into a single integrated architecture enabling end-to-end server visibility, management, and control in both bare metal and virtualized environments.

See [Figure 1 on page 3](#) for front and rear views of all the configurations of the UCS C240 M7 server.

Notes:

1. Available post first customer ship (FCS)

Figure 1 Cisco UCS C240 M7 SFF Rack Server
Option 1

Up to 24 front facing SFF SAS/SATA HDDs or SAS/SATA SSDs or NVMe SSDs (optionally up to 4 of the slots can be direct-attach NVMe)
Front View (all slots shown unpopulated - see [Figure 2 on page 4](#) for details)



Rear View (all slots shown unpopulated - see [Figure 3 on page 5](#) for details)

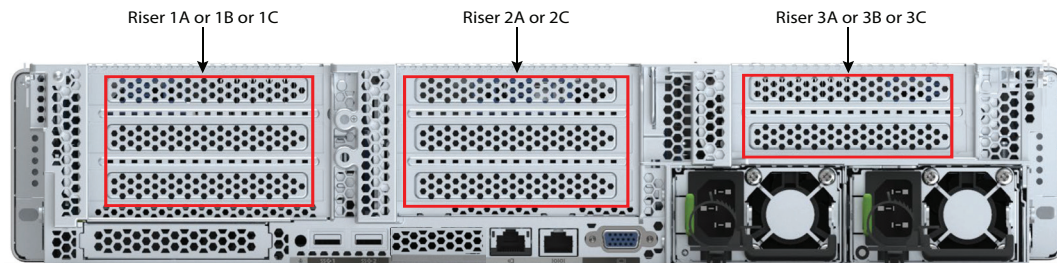

Option 2

Up to 24 front facing SFF NVMe SSDs only (drives are direct-attach to PCIe Gen4 x2)
Front View (all slots shown unpopulated - see [Figure 4 on page 7](#) for details)



Rear View (all slots shown unpopulated - see [Figure 5 on page 8](#) for details)

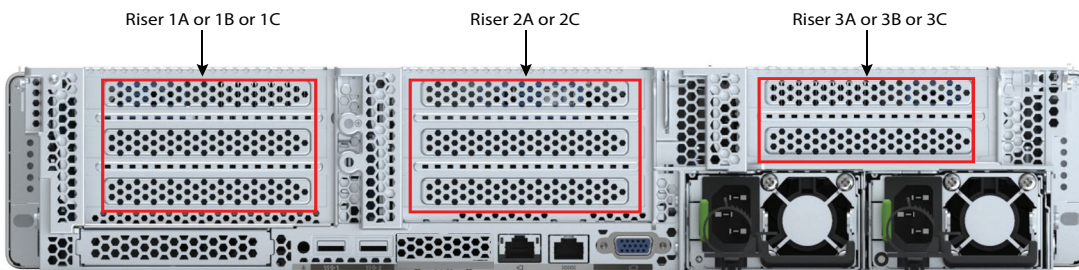

DETAILED VIEWS

Chassis Front View - Option 1

Figure 2 shows the front view of Cisco UCS C240 M7 SFF rack server configured with 24 front drives.

Figure 2 Chassis Front View (Option 1 - UCSC-C240-M7SX)

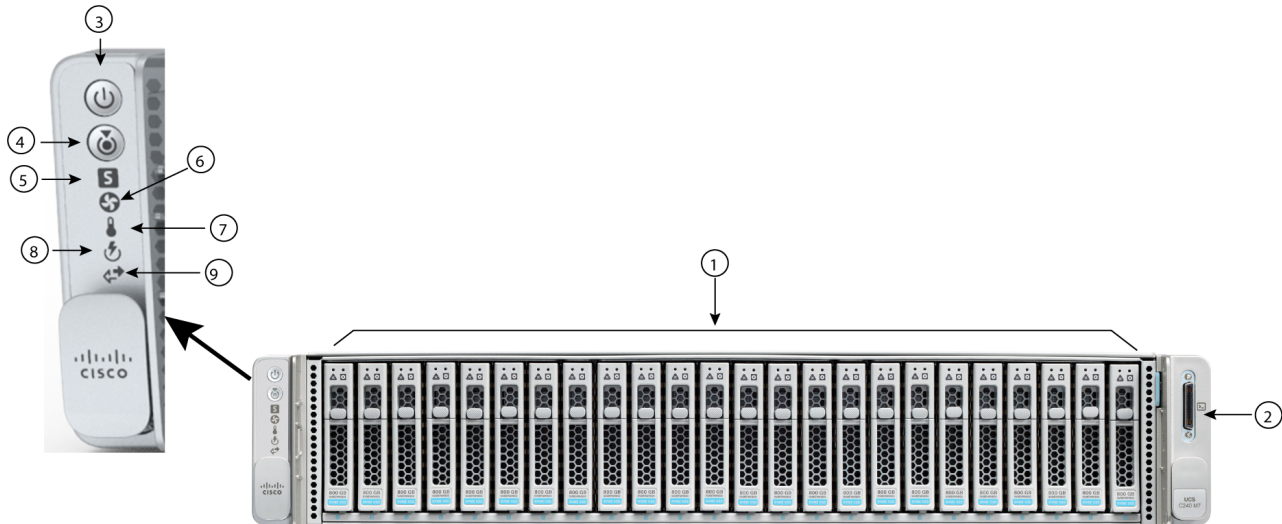

1	Drive bays 1 - 24 supports up to 24 front facing SFF SAS/SATA HDDs or SAS/SATA SSDs or NVMe SSDs (optionally up to 4 of the slots can be direct-attach NVMe).	6	Fan status LED
2	KVM connector (used with KVM cable that provides two USB 2.0, one VGA, and one serial connector)	7	Temperature status LED
3	Power button/Power status LED	8	Power supply status LED
4	Unit Identification button/LED	9	Network link activity LED
5	System status LED	-	-

Chassis Rear View

Figure 3 shows the external features of the rear panel.

Figure 3 Chassis Rear View (UCSC-C240-M7SX)

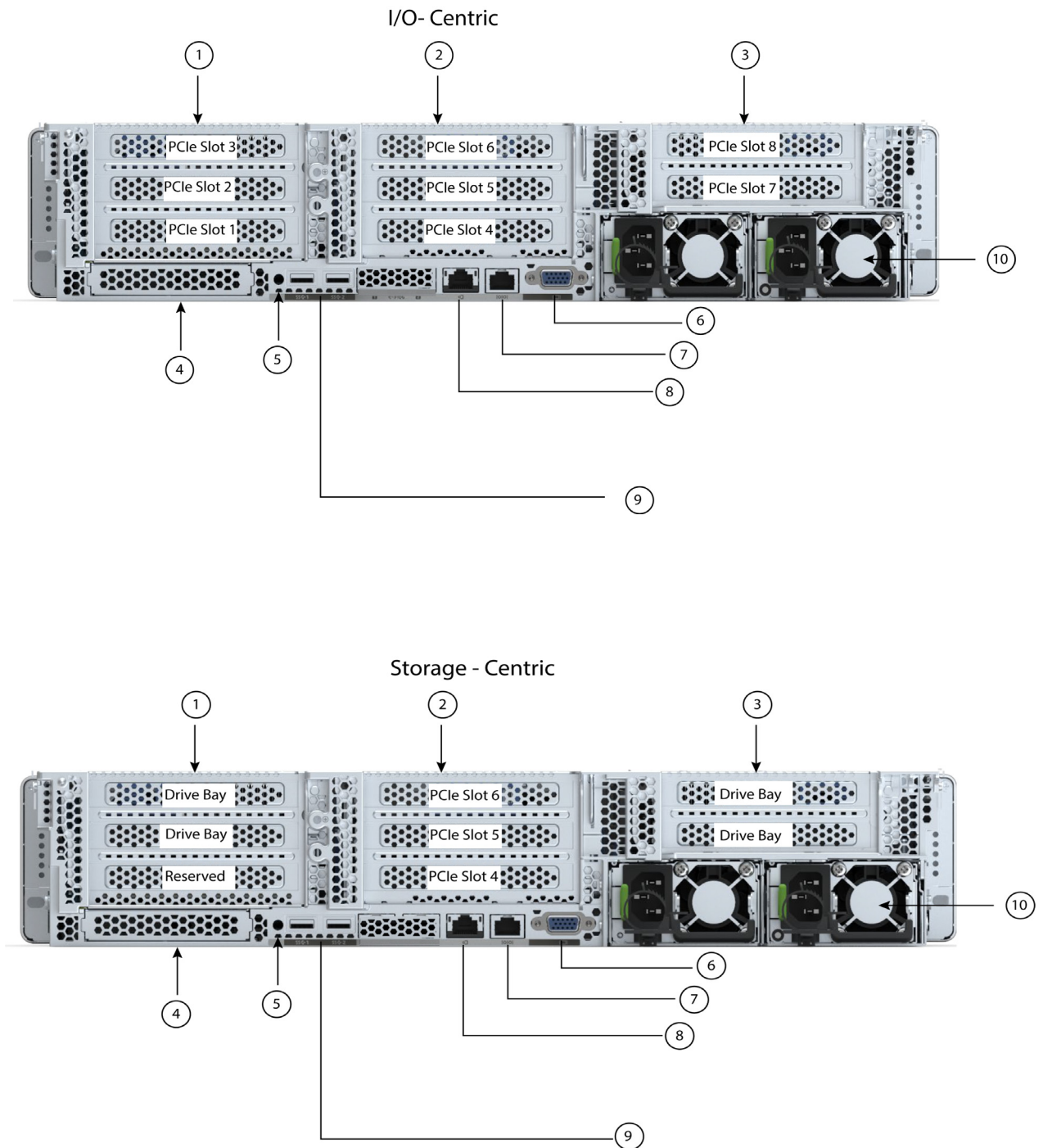

1	<p>There are three Riser 1 options:</p> <p>Riser 1A (I/O-centric, Gen 4, CPU1 control) Supports three Gen 4 PCIe slots:</p> <ul style="list-style-type: none"> ■ Slot 1 is full-height, 3/4 length, x8, NCSI, single wide GPU ■ Slot 2 is full-height, full-length, x16, NCSI, single/double wide GPU ■ Slot 3 is full-height, full-length, x8, no NCSI, single wide GPU <p>Riser 1B (storage-centric, CPU1 control) Supports two drive bays:</p> <ul style="list-style-type: none"> ■ Slot 1 is reserved ■ Drive bay 102, x4, SAS/SATA/NVMe ■ Drive bay 101, x4, SAS/SATA/NVMe <p>Riser 1C (I/O-centric, Gen 5, CPU1 control) Supports two Gen 5 PCIe slots:</p> <ul style="list-style-type: none"> ■ Slot 1 is full-height, 3/4 length, x16, NCSI, single wide GPU ■ Slot 2 is full-height, full-length, x16, no NCSI, single/double wide GPU 	6	VGA display port (DB15 connector)
2	<p>There are two Riser 2 options:</p> <p>Riser 2A (I/O-centric, Gen 4, CPU2 control) Supports three Gen 4 PCIe slots:</p> <ul style="list-style-type: none"> ■ Slot 4 is full-height, 3/4 length, x8, NCSI, single wide GPU ■ Slot 5 is full-height, full-length, x16, NCSI, single/double wide GPU ■ Slot 6 is full-height, full length, x8, no NCSI, single wide GPU <p>Riser 2C (I/O-centric, Gen 5, CPU2 control) Supports two Gen 5 PCIe slots:</p> <ul style="list-style-type: none"> ■ Slot 4 is full-height, 3/4 length, x16, NCSI, single wide GPU ■ Slot 5 is full-height, full-length, x16, no NCSI, single/double wide GPU 	7	COM port (RJ45 connector)
3	<p>There are three Riser 3 options</p> <p>Riser 3A (I/O-centric, CPU2 control) Supports two PCIe slots:</p> <ul style="list-style-type: none"> ■ Slot 7 is full-height, full-length, x8, no NCSI, no GPU ■ Slot 8 is full-height, full-length, x8, no NCSI, no GPU <p>Riser 3B (storage-centric, CPU2 control) Supports two drive bays:</p> <ul style="list-style-type: none"> ■ Drive bay 104, x4, SAS/SATA/NVMe ■ Drive bay 103, x4, SAS/SATA/NVMe <p>Riser 3C (for GPU, CPU2 control) Supports one PCIe Slot:</p> <ul style="list-style-type: none"> ■ Slot 7 is one full-height, full-length, x16, no NCSI, double wide GPU ■ Slot 8 is blocked by double wide GPU (not used) 	8	1 GbE dedicated Ethernet management port
4	Modular LAN-on-motherboard (mLOM)/OCP 3.0 card slot (x16)	9	USB 3.0 ports (two)
5	System ID pushbutton/LED	10	Power supplies (two)

Chassis Front View - Option 2

Figure 4 shows the front view of Cisco UCS C240 M7 SFF rack server configured with 24 drives.

Figure 4 Chassis Front View (Option 2 - UCSC-C240-M7SN)

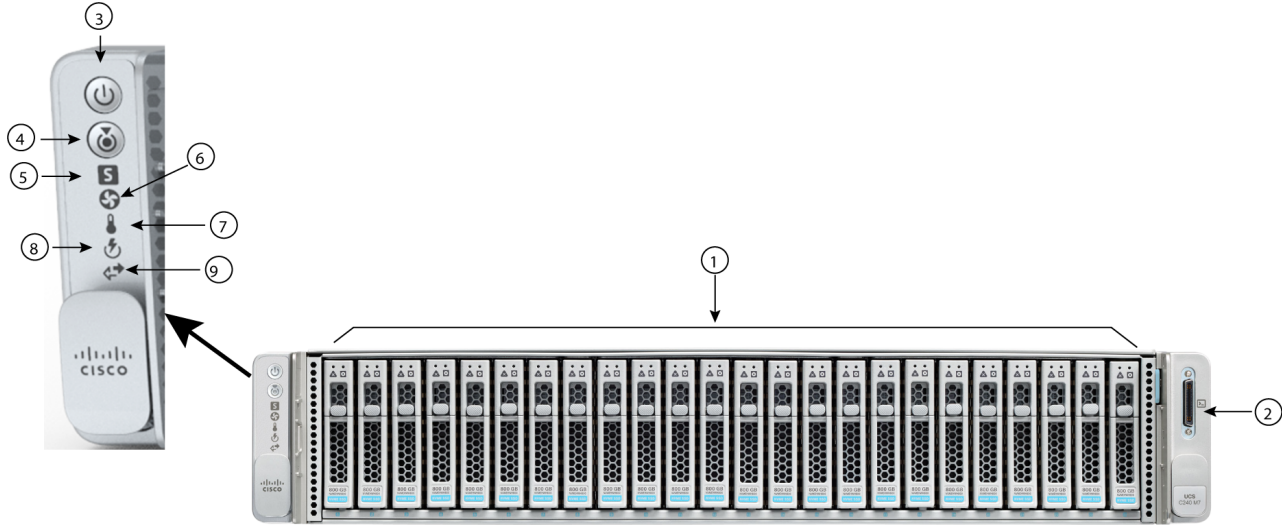

1	Drive bays 1 - 24 support NVMe PCIe drives (only) ¹	6	Fan status LED
2	KVM connector (used with KVM cable that provides two USB 2.0, one VGA, and one serial connector)	7	Temperature status LED
3	Power button/Power status LED	8	Power supply status LED
4	Unit Identification button/LED	9	Network link activity LED
5	System status LED	-	-

Notes:

- 1. If NVMe drives are selected, you must also select 2 CPUs.

Chassis Rear View - Option 2

Figure 3 shows the external features of the rear panel.

Figure 5 Chassis Rear View (Option 2 - UCSC-C240-M7SN)

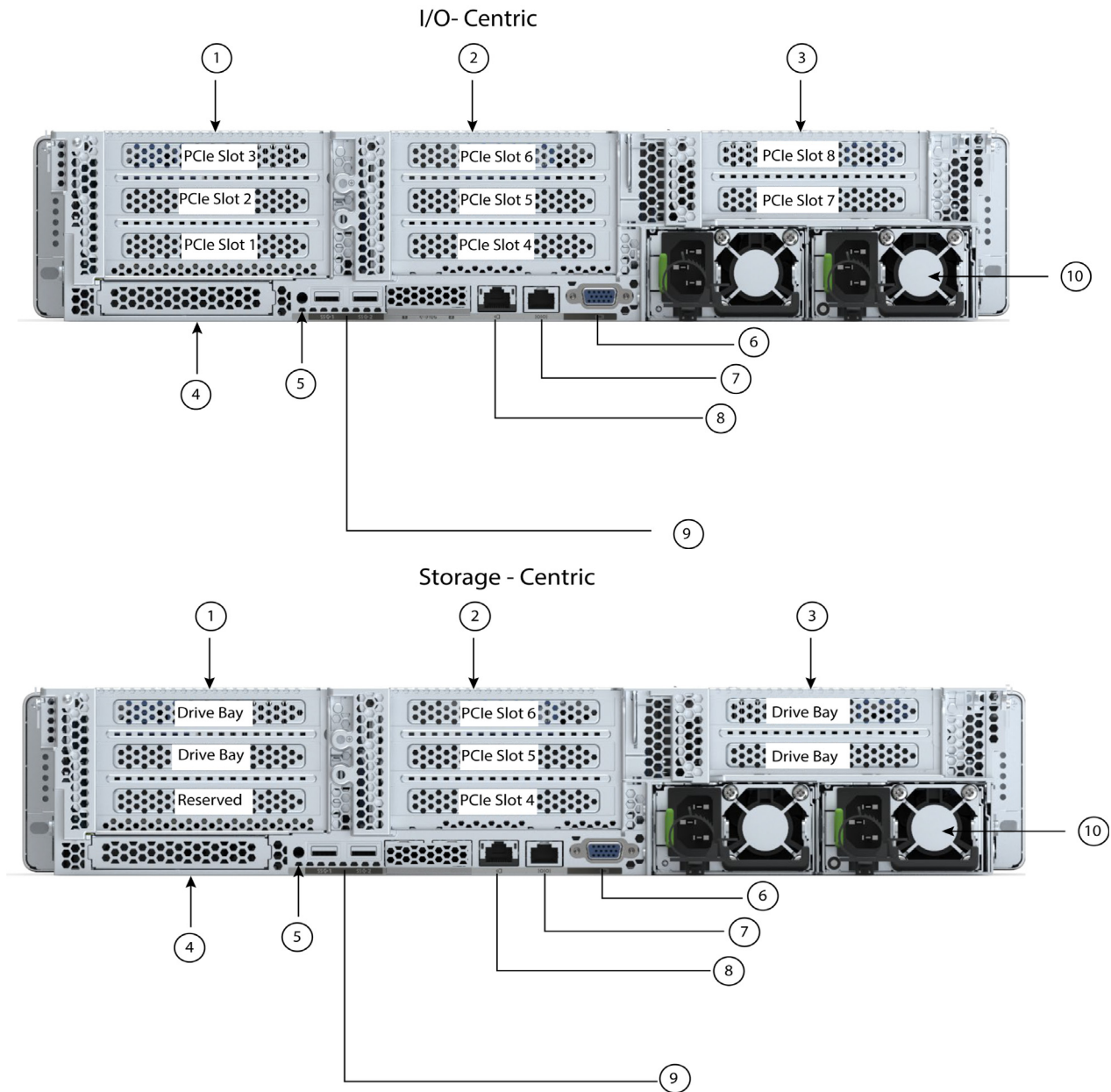

1	<p>There are three Riser 1 options:</p> <p>Riser 1A (I/O-centric, Gen 4, CPU1 control) Supports three Gen 4 PCIe slots:</p> <ul style="list-style-type: none"> ■ Slot 1 is full-height, 3/4 length, x8, NCSI, single wide GPU ■ Slot 2 is full-height, full-length, x16, NCSI, single/double wide GPU ■ Slot 3 is full-height, full-length, x8, no NCSI, single wide GPU <p>Riser 1B (storage-centric, CPU1 control) Supports two drive bays:</p> <ul style="list-style-type: none"> ■ Slot 1 is reserved ■ Drive bay 102, x4, NVMe ■ Drive bay 101, x4, NVMe <p>Riser 1C (I/O-centric, Gen 5, CPU1 control) Supports two Gen 5 PCIe slots:</p> <ul style="list-style-type: none"> ■ Slot 1 is full-height, 3/4 length, x16, NCSI, single wide GPU ■ Slot 2 is full-height, full-length, x16, no NCSI, single/double wide GPU 	6	VGA display port (DB15 connector)
2	<p>There are two Riser 2 options:</p> <p>Riser 2A (I/O-centric, Gen 4, CPU2 control) Supports three Gen 4 PCIe slots:</p> <ul style="list-style-type: none"> ■ Slot 4 is full-height, 3/4 length, x8, NCSI, single wide GPU ■ Slot 5 is full-height, full-length, x16, NCSI, single/double wide GPU ■ Slot 6 is full-height, full length, x8, no NCSI, single wide GPU <p>Riser 2C (I/O-centric, Gen 5, CPU2 control) Supports two Gen 5 PCIe slots:</p> <ul style="list-style-type: none"> ■ Slot 4 is full-height, 3/4 length, x16, NCSI, single wide GPU ■ Slot 5 is full-height, full-length, x16, no NCSI, single/double wide GPU 	7	COM port (RJ45 connector)
3	<p>There are three Riser 3 options</p> <p>Riser 3A (I/O-centric, CPU2 control) Supports two PCIe slots:</p> <ul style="list-style-type: none"> ■ Slot 7 is full-height, full-length, x8, no NCSI, no GPU ■ Slot 8 is full-height, full-length, x8, no NCSI, no GPU <p>Riser 3B (storage-centric, CPU2 control) Supports two drive bays:</p> <ul style="list-style-type: none"> ■ Drive bay 104, x4, NVMe ■ Drive bay 103, x4, NVMe <p>Riser 3C (for GPU, CPU2 control) Supports one PCIe Slot:</p> <ul style="list-style-type: none"> ■ Slot 7 is one full-height, full-length, x16, no NCSI, double wide GPU ■ Slot 8 is blocked by double wide GPU (not used) 	8	1 GbE dedicated Ethernet management port
4	Modular LAN-on-motherboard (mLOM)/OCP 3.0 card slot (x16)	9	USB 3.0 ports (two)
5	System ID pushbutton/LED	10	Power supplies (two)

BASE SERVER STANDARD CAPABILITIES and FEATURES

Table 1 lists the capabilities and features of the base server. Details about how to configure the server for a particular feature or capability (for example, number of processors, disk drives, or amount of memory) are provided in *CONFIGURING the SERVER, page 13*.

Table 1 Capabilities and Features

Capability/Feature	Description
Chassis	Two rack unit (2RU) chassis
CPU	<ul style="list-style-type: none"> ■ One or two 4th Gen Intel® Xeon® Scalable Processors (codenamed Sapphire Rapids). ■ Each CPU has 8 channels with up to 2 DIMMs per channel, for up to 16 DIMMs per CPU. ■ UPI Links: Up to 4 at 16GT/s
Chipset	Intel® C741 series chipset
Memory	<ul style="list-style-type: none"> ■ 32 total DDR5-4800 MT/s DIMM slots (16 per CPU) ■ 50% peak bandwidth increase over DDR4-3200, with on-die ECC; all densities are Registered DIMMs (RDIMMs) ■ Up to 8TB DDR5-4800 MT/s Memory DIMM capacity (32x 256GB DIMMs)
Video	<p>The Cisco Integrated Management Controller (CIMC) provides video using the Matrox G200e video/graphics controller:</p> <ul style="list-style-type: none"> ■ Integrated 2D graphics core with hardware acceleration ■ Embedded DDR memory interface supports up to 512 MB of addressable memory (8 MB is allocated by default to video memory) ■ Supports display resolutions up to 1920 x 1200 16bpp @ 60Hz ■ High-speed integrated 24-bit RAMDAC ■ Single lane PCI-Express host interface running at Gen 1 speed
Power subsystem	<p>Up to two of the following hot-swappable power supplies:</p> <ul style="list-style-type: none"> ■ 1050 W (DC) ■ 1200 W (AC) ■ 1600 W (AC) ■ 2300 W (AC) <p>One power supply is mandatory; one more can be added for 1 + 1 redundancy.</p>
Fans	Six hot-swappable fans for front-to-rear cooling
Front Panel	A front panel controller provides status indications and control buttons.
ACPI	This server supports the advanced configuration and power interface (ACPI) 6.2 standard.
Infiniband	The InfiniBand architecture is supported by the PCIe slots.

Capability/ Feature	Description
Expansion slots	<ul style="list-style-type: none"> ■ Riser 1A (three Gen 4 PCIe slots) ■ Riser 1B (two drive bays) ■ Riser 1C (two Gen 5 PCIe slots) ■ Riser 2A (three Gen 4 PCIe slots) ■ Riser 2C (two Gen 5 PCIe slots) ■ Riser 3A (two Gen 4 PCIe slots) ■ Riser 3B (two drive bays) ■ Riser 3C (one full-length, double-wide GPU)  <p>Note: For more details on the variations of riser 1, riser 2, and riser 3, see Riser Card Configurations and Options, page 61.</p>
Internal storage devices	<p><u>Drive Storage:</u> The server is orderable in two different versions:</p> <ul style="list-style-type: none"> ■ UCSC-C240-M7SX (Option 1): <ul style="list-style-type: none"> • Up to 24 front facing SFF SAS/SATA HDDs or SAS/SATA SSDs or NVMe SSDs • Optionally, up to four of the slots can be direct-attach NVMe. These drives must be placed in front drive bays 1, 2, 3, and 4 only. The rest of the bays (5 - 24) can be populated with SAS/SATA/NVMe SSDs or HDDs. Two CPUs are required when choosing NVMe SSDs. • Optionally, up to four SFF rear-facing SAS/SATA/NVMe drives ■ UCSC-C240-M7SN (Option 2): <ul style="list-style-type: none"> • Up to 24 front NVMe drives (only). • Optionally, up to 4 rear NVMe drives (only) • Two CPUs are required when choosing NVMe SSDs <p><u>Other storage:</u></p> <ul style="list-style-type: none"> ■ A mini-storage module connector on the motherboard supports a boot-optimized RAID controller carrier that holds up to two SATA M.2 SSDs. ■ 8GB FlexMMC utility storage for staging of firmware and other user data. 8GB FlexMMC storage is built into the motherboard on M7.
Storage controllers	<p><u>Internal storage controllers:</u> The 24G Tri-mode RAID controller, 12G RAID controller or 12G SAS HBA. Only one of the raid controller at a time can be used.</p> <ul style="list-style-type: none"> ■ Cisco 24G Tri-mode RAID controller¹ <ul style="list-style-type: none"> • RAID support (RAID 0, 1, 5, 6, 10, 50, 60, RAID0, and RAID00) • Supports up to 14 internal SAS/SATA/NVMe drives ■ Cisco 12G RAID controller <ul style="list-style-type: none"> • RAID support (RAID 0, 1, 5, 6, 10, 50, 60, RAID0, and RAID00) • Supports up to 28 internal SAS/SATA drives ■ Cisco 12G SAS HBA <ul style="list-style-type: none"> • No RAID support • JBOD/Pass-through Mode support • Supports up to 14 SAS/SATA internal drives <p><u>External storage controllers:</u></p> <ul style="list-style-type: none"> ■ Cisco 12G 9500-8e 12G SAS HBA for external JBOD attach

Capability/ Feature	Description
Modular LAN on Motherboard (mLOM)/Open Compute Project (OCP) 3.0 slot	The dedicated mLOM/OCP 3.0 slot on the motherboard can flexibly accommodate the following cards: <ul style="list-style-type: none"> ■ Cisco Virtual Interface Cards ■ OCP 3.0 network interface card
Interfaces	<ul style="list-style-type: none"> ■ Rear panel: <ul style="list-style-type: none"> • One 1Gbase-T RJ-45 management port • One RS-232 serial port (RJ45 connector) • One DB15 VGA connector • Two USB 3.0 port connectors • One flexible modular LAN on motherboard (mLOM)/OCP 3.0 slot that can accommodate various interface cards. ■ Front panel: <ul style="list-style-type: none"> • One KVM console connector (supplies two USB 2.0 connectors, one VGA DB15 video connector, and one serial port (RS232) RJ45 connector)
Integrated management processor	Baseboard Management Controller (BMC) running Cisco Integrated Management Controller (CIMC) firmware. Depending on your CIMC settings, the CIMC can be accessed through the 1GE dedicated management port, the 1GE/10GE LOM ports, or a Cisco virtual interface card (VIC). CIMC manages certain components within the server, such as the Cisco 12G SAS HBA.
UCSM ²	UCS Manager (UCSM) 4.3(2) or later runs in the Fabric Interconnect and automatically discovers and provisions some of the server components.
Intersight	Intersight provides server management capabilities
CIMC	Cisco Integrated Management Controller 4.3(1) or later

CONFIGURING the SERVER

Follow these steps to configure the Cisco UCS C240 M7 SFF Rack Server:

- [STEP 1 SELECT SERVER SKU, page 14](#)
- [STEP 2 SELECT RISER CARDS \(REQUIRED\), page 15](#)
- [STEP 3 SELECT CPU\(s\) \(REQUIRED\), page 17](#)
- [STEP 4 SELECT MEMORY \(REQUIRED\), page 21](#)
- [STEP 5 SELECT DRIVE CONTROLLERS \(OPTIONAL\), page 26](#)
- [STEP 6 SELECT DRIVES \(OPTIONAL\), page 30](#)
- [STEP 7 SELECT PCIe CARD\(s\) \(OPTIONAL\), page 35](#)
- [STEP 8 ORDER GPU CARDS \(OPTIONAL\), page 38](#)
- [STEP 9 ORDER POWER SUPPLY \(REQUIRED\), page 41](#)
- [STEP 10 SELECT INPUT POWER CORD\(s\) \(REQUIRED\), page 42](#)
- [STEP 11 ORDER TOOL-LESS RAIL KIT \(REQUIRED\) AND REVERSIBLE CABLE MANAGEMENT ARM \(OPTIONAL\), page 46](#)
- [STEP 12 SELECT MANAGEMENT CONFIGURATION \(OPTIONAL\), page 47](#)
- [STEP 13 ORDER SECURITY DEVICES \(REQUIRED\), page 48](#)
- [STEP 14 SELECT LOCKING SECURITY BEZEL \(OPTIONAL\), page 49](#)
- [STEP 15 ORDER M.2 SATA SSDs \(OPTIONAL\), page 50](#)
- [STEP 16 SELECT OPERATING SYSTEM AND VALUE-ADDED SOFTWARE, page 51](#)
- [STEP 17 CHOOSE OPTIONAL OPERATING SYSTEM MEDIA KIT, page 54](#)

STEP 1 SELECT SERVER SKU

Top level ordering product ID (PID) is shown in [Table 2](#)

Table 2 Top level ordering PID (major line bundle)

Product ID (PID)	Description
UCS-M7-MLB	UCS M7 RACK MLB This major line bundle (MLB) consists of the Rack Server (UCSC-C240-M7SX or UCSC-C240-M7SN) with software PIDs. Use this PID to begin a new configuration.

Select one server product ID (PID) from [Table 3](#).



CAUTION: This products may not be purchased outside of the approved bundles. (must be ordered under the MLB)

Table 3 PID of Cisco UCS C240 M7 SFF Rack Base Server

Product ID (PID)	Description
UCSC-C240-M7SX (Option 1)	Small form-factor (SFF) drives, with 24-drive backplane. <ul style="list-style-type: none"> ■ Front facing drive bays 1-24 support 2.5in SAS/SATA/NVMe SSDs depending on controller type installed. ■ Optionally, front-loading drive bays 1, 2, 3, and 4 support 2.5-inch direct-attach NVMe SSDs. ■ Optionally, 4 rear facing SAS/SATA/NVMe drives
UCSC-C240-M7SN (Option 2)	Small form-factor (SFF) drives, with 24-drive backplane. <ul style="list-style-type: none"> ■ Front-loading drive bays 1–24 support 2.5-inch NVMe (only) drives. ■ Optionally, 4 rear facing NVMe (only) drives

The Cisco UCS C240 M7 SFF Server:

- Includes a 24 drive backplane.
- Does not include power supply, CPU, memory, hard disk drives (HDDs), solid-state drives (SSDs), NVMe drives, SD cards, riser 1, riser 2, riser 3, tool-less rail kit, or PCIe cards.
- Use the steps on the following pages to configure the server with the components that you want to include.

STEP 2 SELECT RISER CARDS (REQUIRED)

Select desired risers from [Table 4](#).



CAUTION:

- Mixing storage riser and I/O Risers are not allowed with the exception of Riser 2
- Mixing Gen 4 and Gen 5 Risers are not allowed with the exception of Riser 3.

Table 4 PIDs of the Risers



Product ID (PID)	Description
Option 1	
UCSC-RIS1A-240-D (I/O riser, Gen 4)	<p>C240 M7 Riser 1A PCIe Gen4 (controlled with CPU1)</p> <ul style="list-style-type: none"> ■ Slot 1 is full-height, 3/4 length, x8, Supports NCSI and single wide GPU ■ Slot 2 is full-height, full-length, x16, Supports NCSI and single/double wide GPU ■ Slot 3 is full-height, full-length, x8, Supports single wide GPU <p> Note: This riser can only be select with UCSC-RIS2A-240-D, UCSC-RIS3A-240-D or UCSC-RIS3C-240-D.</p>
UCSC-RIS1B-24XM7 (storage riser)	<p>C240 M7 Riser 1B (controlled with CPU1)</p> <ul style="list-style-type: none"> ■ Slot 1 is reserved ■ Drive bay 102, x4, Supports SAS/SATA/NVMe drives ■ Drive bay 101, x4, Supports SAS/SATA/NVMe drives <p> Note: This riser Can only be select with UCSC-RIS2A-240-D or UCSC-RIS2C-24XM7, and UCSC-RIS3B-24XM7.</p>
UCSC-RIS1C-24XM7 (I/O riser, Gen 5)	<p>C240 M7 Riser 1C PCIe Gen 5 (controlled with CPU1)</p> <ul style="list-style-type: none"> ■ Slot 1 is full-height, 3/4 length, x16, Supports NCSI and single wide GPU ■ Slot 2 is full-height, full-length, x16, supports single/double wide GPU <p> Note: This riser Can only be select with UCSC-RIS2C-240M7, UCSC-RIS3A-240-D or UCSC-RIS3C-240-D.</p>
Option 2 (2-CPU must be selected)	
UCSC-RIS2A-240-D (I/O riser, Gen 4)	<p>C240 M7 Riser 2A PCIe Gen4 (controlled with CPU2)</p> <ul style="list-style-type: none"> ■ Slot 4 is full-height, 3/4 length, x8, Supports NCSI and single wide GPU ■ Slot 5 is full-height, full-length, x16, Supports NCSI and single/double wide GPU ■ Slot 6 is full-height, full length, x8, Supports single wide GPU

Table 4 PIDs of the Risers

Product ID (PID)	Description
UCSC-RIS2C-24XM7 (I/O riser, Gen 5)	C240 M7 Riser 2C PCIe Gen5 (controlled with CPU2) <ul style="list-style-type: none"> ■ Slot 4 is full-height, 3/4 length, x16, Supports NCSI and single wide GPU ■ Slot 5 is full-height, full-length, x16, Supports single/double wide GPU
Option 3 (2-CPU must be selected)	
UCSC-RIS3A-240-D (I/O riser, Gen 4)	C240 M7 Riser 3A PCIe Gen4 (controlled with CPU2) <ul style="list-style-type: none"> ■ Slot 7 is full-height, full-length, x8 ■ Slot 8 is full-height, full-length, x8
UCSC-RIS3B-24XM7 (storage riser)	C240 M7 Riser 3B (controlled with CPU2) <ul style="list-style-type: none"> ■ Drive bay 104, x4, SAS/SATA/NVMe drives ■ Drive bay 103, x4, SAS/SATA/NVMe drives
UCSC-RIS3C-240-D (GPU riser)	C240 M7 Riser 3C (controlled with CPU2) <ul style="list-style-type: none"> ■ Slot 7 is one full-height, full-length, x16, Supports double wide GPU ■ Slot 8 is blocked by double wide GPU (not used)
Accessories/spare included along with selected risers: <ul style="list-style-type: none"> ■ UCSC-FBRS2-C240-D for riser 2 and UCSC-FBRS3-C240-D riser filler blank for riser 3 is auto included, if riser 2 or riser 3 are not selected. ■ CBL-RSASR1B-240-D is auto included with selection of riser 1 and Raid controller (UCSC-RAID-T-D) ■ CBL-R1B-SD-240-D is auto included with selection of riser 1 and Raid controller (UCSC-RAID-SD-D). ■ CBL-SASR1B-C24XM7 is auto included with selection of riser 1 and Raid controller (UCSC-RAID-HP). ■ CBL-RSASR3B-240-D is auto included with selection of riser 3 and Raid controller (UCSC-RAID-T-D or UCSC-RAID-SD-D). ■ CBL-SASR3B-C24XM7 is auto included with selection of riser 3 and Raid controller (UCSC-RAID-HP). <p>NOTE: Please note, if you are adding additional risers and raid controller later, you may need to order the accessories with it.</p>	

**NOTE:**

- For additional details on riser cards, see [Riser Card Configurations and Options, page 61](#)
- For GPU support on a particular riser slot, see [Table 5 on page 38](#)

STEP 3 SELECT CPU(s) (REQUIRED)

The standard CPU features are:

- The 4th Gen Intel® Xeon® Scalable Processors (codenamed Sapphire Rapids) are paired with Intel® C741 series chipset
- Up to 60 cores
- Cache size of up to 112.50 MB
- Power: Up to 350Watts
- UPI Links: Up to 4 at 16GT/s

Select CPUs

The available CPUs are listed in [Table 5](#). See [Table 6 on page 19](#) for CPU suffix notations.



CAUTION: Normal operating temperature is limited to 35° C [95° F], for the 2U NVMe/SAS SKU, and is lowered to 28° C [82.4° F], with a fan fault. When rear drives are installed, the normal operating temperature is lowered to 30° C [86° F], and 26° C [78.8° F], respectively with a fan fault.

When GPUs are installed, CPU TDP is limited to 300W. With a single GPU installed, normal operating temperature is 32° C [89.6° F], lowered to 28° C [82.4° F], with a fan fault. With multiple GPU installed, normal operating temperature is 30° C [86° F], lowered to 25° C [77° F], with a fan fault.

Table 5 Available CPUs

Product ID (PID)	Segment/Workload	Maximum Socket (S)	Cores (C)	Clock Freq (GHz)	Power (W)	Cache Size (MB)	Highest DDR5 DIMM Clock Support (MT/s)
8000 Series Processors							
UCS-CPU-I8490H	IMDB/Analytics	2S	60	1.90	350	112.50	4800
UCS-CPU-I8480+	2S Performance	2S	56	2.00	350	105.00	4800
UCS-CPU-I8471N	5G/Networking	1S	52	1.80	300	97.50	4800
UCS-CPU-I8470N	5G/Networking	2S	52	1.70	300	97.50	4800
UCS-CPU-I8470	2S Performance	2S	52	2.00	350	105.00	4800
UCS-CPU-I8468V	Cloud/SaaS/Media	2S	48	2.40	330	97.50	4800
UCS-CPU-I8468H	IMDB/Analytics	2S	48	2.10	330	105.00	4800
UCS-CPU-I8468	2S Performance	2S	48	2.10	350	105.00	4800
UCS-CPU-I8462Y+	2S Performance	2S	32	2.80	300	60.00	4800
UCS-CPU-I8461V	Cloud/SaaS/Media	1S	48	2.20	300	97.50	4800

Table 5 Available CPUs

Product ID (PID)	Segment/Workload	Maximum Socket (S)	Cores (C)	Clock Freq (GHz)	Power (W)	Cache Size (MB)	Highest DDR5 DIMM Clock Support (MT/s)
UCS-CPU-I8460Y+	2S Performance	2S	40	2.00	300	105.00	4800
UCS-CPU-I8460H	IMDB/Analytics	2S	40	2.20	330	105.00	4800
UCS-CPU-I8458P	Cloud/SaaS/Media	2S	44	2.70	350	82.50	4800
UCS-CPU-I8454H	IMDB/Analytics	2S	32	2.10	270	82.50	4800
UCS-CPU-I8452Y	2S Mainline	2S	36	2.00	300	67.50	4800
UCS-CPU-I8450H	IMDB/Analytics	2S	28	2.00	250	75.00	4800
UCS-CPU-I8444H	IMDB/Analytics	2S	16	2.90	270	45.00	4800
6000 Series Processors							
UCS-CPU-I6454S	Storage	2S	32	2.20	270	60.00	4800
UCS-CPU-I6448Y	2S Performance	2S	32	2.10	225	60.00	4800
UCS-CPU-I6448H	IMDB/Analytics	2S	32	2.40	250	60.00	4800
UCS-CPU-I6444Y	2S Performance	2S	16	3.60	270	45.00	4800
UCS-CPU-I6442Y	2S Performance	2S	24	2.60	225	60.00	4800
UCS-CPU-I6438Y+	2S Mainline	2S	32	2.00	205	60.00	4800
UCS-CPU-I6438N	5G/Networking	2S	32	2.00	205	60.00	4800
UCS-CPU-I6438M	Cloud/SaaS/Media	2S	32	2.20	205	60.00	4800
UCS-CPU-I6434H	IMDB/Analytics	2S	8	3.70	195	22.50	4800
UCS-CPU-I6434	2S Performance	2S	8	3.70	195	22.50	4800
UCS-CPU-I6430	2S Mainline	2S	32	2.10	270	60.00	4400
UCS-CPU-I6428N	5G/Networking	2S	32	1.80	185	60.00	4000
UCS-CPU-I6426Y	2S Performance	2S	16	2.50	185	37.50	4800
UCS-CPU-I6421N	5G/Networking	1S	32	1.80	185	60.00	4400
UCS-CPU-I6418H	IMDB/Analytics	2S	24	2.10	185	60.00	4800
UCS-CPU-I6416H	IMDB/Analytics	2S	18	2.20	165	45.00	4800
UCS-CPU-I6414U	1S gen. purpose	1S	32	2.00	250	60.00	4800
5000 Series Processors							
UCS-CPU-I5420+	2S Mainline	2S	28	2.00	205	52.50	4400
UCS-CPU-I5418Y	2S Mainline	2S	24	2.00	185	45.00	4400
UCS-CPU-I5418N	5G/Networking	2S	24	1.80	165	45.00	4000
UCS-CPU-I5416S	Storage	2S	16	2.00	150	30.00	4400
UCS-CPU-I5415+	2S Performance	2S	8	2.90	150	22.50	4400

Table 5 Available CPUs

Product ID (PID)	Segment/Workload	Maximum Socket (S)	Cores (C)	Clock Freq (GHz)	Power (W)	Cache Size (MB)	Highest DDR5 DIMM Clock Support (MT/s)
UCS-CPU-I5412U	1S gen. purpose	1S	24	2.10	185	45.00	4400
UCS-CPU-I5411N	5G/Networking	1S	24	1.90	165	45.00	4400
4000 Series Processors							
UCS-CPU-I4416+	2S Mainline	2S	20	2.00	165	37.50	4000
UCS-CPU-I4410Y	2S Mainline	2S	12	2.00	150	30.00	4000
UCS-CPU-I4410T	IOT	2S	10	2.70	150	26.25	4000
3000 Series Processors							
UCS-CPU-I3408U	1S gen. purpose	1S	8	1.80	125	22.50	4000
Accessories/spare included with CPU configuration:							
<ul style="list-style-type: none"> ■ UCSC-HSHP-C240M7 							
NOTE: if you are adding a second CPU later, you may need to order accessories spares with it.							

Table 6 CPU Suffixes

CPU Suffix	Description	Features
P	Cloud (IaaS)	Designed for cloud IaaS environments to deliver higher frequencies at constrained TDPs
V	Cloud (SaaS)	Designed for high rack density, maximize VM/core, and lower power VM environment
M	Media Transcode	Designed for Media processing, AI, and HPC workloads
H	DB and Analytics	Designed for Data Analytics and Big Data usages
N	Network/5G/Edge (High TDP/Low latency)	Designed and optimized for a range of broadly-deployed network and 5G workload environments from Edge to the Data Center
S	Storage & HCI	Designed for Storage usages and workloads
T	Long-life Use/High Tcase	Designed for Network Environment-Building System (NEBS) and IoT market
U	1-Socket	Optimized for targeted platforms adequately served by the cores, memory bandwidth and IO capacity available from a single processor
Y	General SKU with SST-PP	Designator is used for general SKU stack to highlight SST-PP (Speed Select Technology Performance Profile) feature enabled
+	Feature Plus SKU	Designed to enable 1 instance of each DSA, IAA, QAT, DLB embedded accelerator

Supported Configurations

(1) Configurations with UCSC-C240-M7SN:

- You must select two identical CPUs from [Table 5 Available CPUs, page 17](#)

(2) Configurations with UCSC-C240-M7SX:

- 1-CPU Configuration:
 - Choose one CPU from [Table 5 Available CPUs, page 17](#)
 - Up to 2 front facing direct-attach NVMe drives are allowed
 - Up to 2 rear facing direct-attach NVMe drives are allowed
- 2-CPU Configuration:
 - Choose two identical CPUs from [Table 5 Available CPUs, page 17](#)
 - Up to 4 front facing direct-attach NVMe drives are allowed
 - Up to 4 rear facing direct-attach NVMe drives are allowed
 - 24G Tri-Mode RAID Controller requires 2-CPU configuration



NOTE:

- You cannot have two I8471N, or two I8461V, two I6421N, two I6414U, two I5412U, two I5411N or two I3408U CPUs in a two-CPU configuration.
 - If you configure a server with one I8471N, or one I8461V, one I6421N, one I6414U, one I5412U, one I5411N or one I3408U CPU you cannot later upgrade to a 2-CPU system with two of these CPUs.
-

The selection of 1 or 2 CPUs depends on the desired server functionality. See the following sections:

- [STEP 4 SELECT MEMORY \(REQUIRED\), page 21](#)
- [STEP 5 SELECT DRIVE CONTROLLERS \(OPTIONAL\), page 26](#)
- [STEP 6 SELECT DRIVES \(OPTIONAL\), page 30](#)
- [STEP 7 SELECT PCIe CARD\(s\) \(OPTIONAL\), page 35](#)

STEP 4 SELECT MEMORY (REQUIRED)

The [Table 7](#) below describes the main memory DIMM features supported on Cisco UCS C240 M7 rack server.



CAUTION: 256GB DIMMs cannot be combined with GPU cards, and the ambient temperature shall be limited to a maximum of 28°C.

Table 7 C240 M7 Main Memory Features

Memory DIMM server technologies	Description
Maximum DDR5 memory clock speed	Up to 4800MT/s 1DPC; Up to 4400MT/S 2DPC
Operational voltage	1.1 Volts
DRAM Fab. density	16Gb
DRAM DIMM type	RDIMM (Registered DDR5 DIMM with on die ECC)
Memory DIMM organization	Eight memory DIMM channels per CPU; up to 2 DIMMs per channel
Maximum number of DRAM DIMM per server	32 (2-Socket)
DRAM DIMM densities and ranks	16GB 1Rx8, 32GB 1Rx4, 64GB 2Rx4, 128GB 4Rx4, 256GB 8Rx4
Maximum system capacity (DRAM DIMMs only)	8TB (32x256GB)

Figure 6 C240 M7 SFF Memory Organization

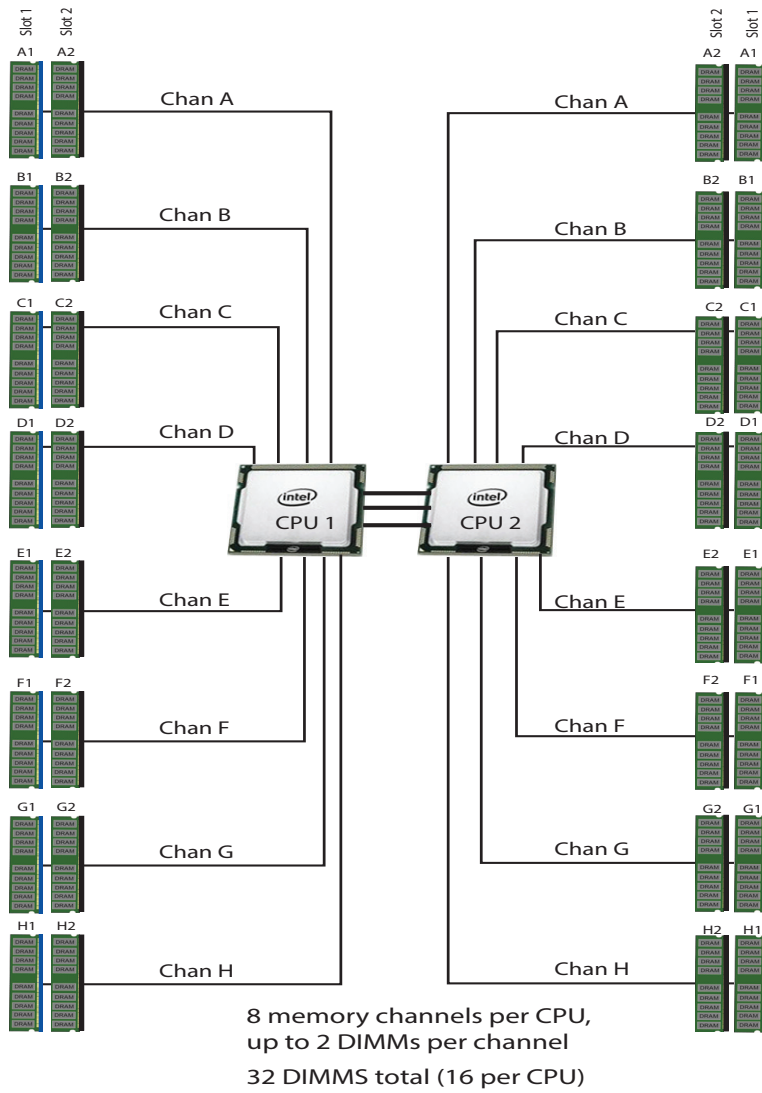

Select DIMMs and Memory Mirroring

Select the memory configuration and whether or not you want the memory mirroring option. The available memory DIMMs and mirroring option are listed in [Table 8](#).



NOTE: When memory mirroring is enabled, the memory subsystem simultaneously writes identical data to two channels. If a memory read from one of the channels returns incorrect data due to an uncorrectable memory error, the system automatically retrieves the data from the other channel. A transient or soft error in one channel does not affect the mirrored data, and operation continues unless there is a simultaneous error in exactly the same location on a DIMM and its mirrored DIMM. Memory mirroring reduces the amount of memory available to the operating system by 50% because only one of the two populated channels provides data.

Table 8 Available DDR5 DIMMs

Product ID (PID)	PID Description
DRAMs	
UCS-MRX16G1RE1	16GB DDR5-4800 RDIMM 1Rx8 (16Gb)
UCS-MRX32G1RE1	32GB DDR5-4800 RDIMM 1Rx4 (16Gb)
UCS-MRX64G2RE1	64GB DDR5-4800 RDIMM 2Rx4 (16Gb)
UCS-MR128G4RE1	128GB DDR5-4800 RDIMM 4Rx4 (16Gb)
UCS-MR256G8RE1 ¹	256GB DDR5-4800 RDIMM 8Rx4 (16Gb)
Memory Mirroring Option	
N01-MMIRRORD	Memory mirroring option
Accessories/spare included with Memory configuration:	
<ul style="list-style-type: none"> ■ UCS-DDR5-BLK² is auto included for the unselected DIMMs slots 	

Notes:

1. 256GB DIMM is available on all C240M7 server models.
2. Any empty DIMM slot must be populated with a DIMM blank to maintain proper cooling airflow.

Memory configurations and mixing rules

- Memory on every CPU socket shall be configured identically.
- System speed is dependent on the CPU DIMM speed support. Refer to [Available CPUs, page 17](#) for DIMM speeds.
- For full details on supported memory configurations see the [M7 Memory Guide](#)
- DIMM Count Rules:
 - Allowed DIMM count for 1-CPU:
 - Minimum DIMM count = 1; Maximum DIMM count = 16
 - 1, 2, 4, 6, 8, 12¹, or 16 DIMMs allowed
 - 3, 5, 7, 9, 10, 11, 13, 14, 15 DIMMs not allowed.
 - Allowed DIMM count for 2-CPU:
 - Minimum DIMM count = 2; Maximum DIMM count = 32
 - 2, 4, 8, 12, 16, 24¹, or 32 DIMMs allowed
 - 6, 10, 14, 18, 20, 22, 26, 28, 30 DIMMs not allowed.

NOTE(1): 12 DIMMs count for 1-CPU, 24 DIMMs count for 2-CPU configurations are only allowed when all DIMMs have the same density.

- DIMM Population Rules:
 - Each channel has two memory slots (for example, channel A = slots A1 and A2).
 - A channel can operate with one or two DIMMs installed.
 - If a channel has only one DIMM, populate slot 1 first (the blue slot).
 - When both CPUs are installed, populate the memory slots of each CPU identically. Fill the blue slots (slot 1) in the memory channels first according to the recommended DIMM populations in [Table 9](#).

Table 9 M7 DIMM Population Order per socket

#DIMMs per CPU	Population of DIMM slots per socket ¹	
	Slot 1 (Blue)	Slot 2 (Black)
1	A1	-
2	A1, G1	-
4	A1, C1, E1, G1	-
6	A1, C1, D1, E1, F1, G1	-
8	A1, B1, C1, D1, E1, F1, G1, H1	-
12 ²	A1, B1, C1, D1, E1, F1, G1, H1	A2, C2, E2, G2
16	A1, B1, C1, D1, E1, F1, G1, H1	A2, B2, C2, D2, E2, F2, G2, H2

Notes:

1. See [DIMM Mixing Rules](#) for allowed combinations across slots 1 and 2.
2. Only valid when DIMMs in blue and black slots are the same density.

- DIMM Mixing Rules:
 - Higher rank DIMMs shall be populated on Slot 1
 - Mixing different DIMM densities in the same slot across channels is not supported. All populated slots of the same color must have the same DIMM density.
 - The DIMM mixing rules matrix is described in the [Table 10](#), below.

Table 10 Supported DIMM mixing and population across 2 slots in each channel

Channel Mixing		DIMM Slot 2 (Black)				
DIMM Slot 1 (Blue)		16GB	32GB	64GB	128GB	256GB
		1Rx8	1Rx4	2Rx4	4Rx4	8Rx4
16GB	1Rx8	Yes ¹	No	No	No	No
32GB	1Rx4	No	Yes ¹	No	No	No
64GB	2Rx4	No	Yes ²	Yes ¹	No	No
128GB	4Rx4	No	No	No	Yes ¹	No
256GB	8Rx4	No	No	No	Yes ²	Yes ¹

Notes:

1. Only 6 or 8 channels are allowed (for 2, 4, or 8 DIMMs you would just populate 1 DPC on 2, 4, or 8 channels)
2. When mixing two different DIMM densities, all 8 channels per CPU must be populated. Use of fewer than 8 channels (16 slots per CPU) is not supported.

■ Memory Limitations:

- Memory on every CPU socket shall be configured identically.
- Refer to [Table 9](#) and [Table 10](#) for DIMM population and DIMM mixing rules.
- Cisco memory from previous generation servers (DDR3 and DDR4) is not supported with the C240 M7 servers.

■ For best performance, observe the following:

- For optimum performance, populate at least one DIMM per memory channel per CPU. When one DIMM per channel is used, it must be populated in DIMM slot 1 (blue slot farthest away from the CPU) of a given channel.
- The maximum 2 DPC speed is 4400 MT/s, refer to [Table 11](#) for the details below.

Table 11 DDR5-4800 DIMM 1DPC and 2DPC max speed matrix

CPU max speed/ DIMM max speed	DDR5 DIMM 1DPC	DDR5 DIMM 2DPC
CPU 4000 MT/s	4000 MT/s	4000 MT/s
CPU 4400 MT/s	4400 MT/s	4400 MT/s
CPU 4800 MT/s	4800 MT/s	4400 MT/s



NOTE: For full details on supported memory configurations see the [M7 Memory Guide](#)

STEP 5 SELECT DRIVE CONTROLLERS (OPTIONAL)

The following list summarizes how drives are controlled on the server:

- Up to 28 SAS/SATA drives are controlled through a Cisco 12G SAS RAID controller.
- Up to 14 SAS/SATA/NVMe drives are controlled through a Cisco 24G Tri-mode RAID controller¹
- Up to 14 SAS/SATA drives are controlled through a Cisco 12G SAS pass-through HBA.



NOTE: PCIe drives are controlled directly from the CPUs.

RAID Volumes and Groups

When creating each RAID volume, follow these guidelines:

- Use the same capacity for each drive in each RAID volume
- For the Cisco 12G SAS RAID controller, use either all SAS HDDs, or all SAS SSDs, or all SATA SSDs in each RAID volume
- For the Cisco 24G Tri-mode RAID controller, use either all SAS HDDs, or all SAS SSDs, or all SATA SSDs or NVMe SSDs in each RAID volume.



NOTE: 240 virtual drives (VDs) per controller, with up to 64 per disk group with the 12G Raid Controller, and 16 per disk group with the 24G Tri Mode Controller.

Notes:

1. Available post first customer ship (FCS).

RAID Controller Options

Select one of the Controllers options for internal drives from the following [Table 12](#).

- Two Cisco 24G Tri-mode RAID controller or
- One Cisco 12G RAID controller or
- Two Cisco 12G SAS HBA



NOTE: If the Cisco 24G Tri-mode RAID controller, 12G SAS RAID controller or Cisco 12G SAS HBA is selected, it is factory-installed in a dedicated slot.

Table 12 Hardware Controller Options

Product ID (PID)	PID Description
Controllers for Internal Drives	
UCSC-RAID-HP ^{1,2}	<p>Cisco Tri-Mode 24G SAS RAID Controller w/4GB Cache</p> <ul style="list-style-type: none"> ■ This RAID controller supports up to 14 SAS HDDs and SAS/SATA/NVMe SSDs operating at 3Gbps, 6Gbps, 12Gbps and 24Gbps. It includes a SuperCap and a 4GB flash-back write cache (FBWC) ■ Supports RAID0, RAID00, 1, 5, 6, 10, 50, 60, and JBOD mode and supports mixed RAID and JBOD mode. ■ The RAID controller plugs directly into a dedicated slot. ■ For all self-encrypting drives (SED), standalone Management (CIMC/UCSM) is supported for configuring and managing local keys. For now, SED drives are managed with local key management only. Third-party key management will be supported (KMIP compliant). ■ Requires 2-CPU configuration.
UCSC-RAID-SD-D	<p>Cisco 12G SAS RAID Controller with 4GB FBWC (28 Drives)</p> <ul style="list-style-type: none"> ■ This RAID controller supports up to 28 SAS HDDs and SAS/SATA SSD operating at 3Gbps, 6Gbps, and 12Gbps. It includes a SuperCap and a 4GB flash-back write cache (FBWC) ■ Supports RAID0, RAID00, 1, 5, 6, 10, 50, 60, and JBOD mode and supports mixed RAID and JBOD mode. ■ The RAID controller plugs directly into a dedicated slot. ■ For all self-encrypting drives (SED), standalone Management (CIMC/UCSM) is supported for configuring and managing local keys. For now, SED drives are managed with local key management only. Third-party key management will be supported (KMIP compliant).
UCSC-SAS-T-D	<p>Cisco M6 12G SAS HBA for (16 Drives)</p> <ul style="list-style-type: none"> ■ This SAS HBA supports up to 14 SAS HDDs and SAS/SATA SSDs operating at 3Gbps, 6Gbps, and 12Gbps. ■ No RAID support ■ Supports JBOD or pass-through mode ■ The 12G SAS HBA plugs directly into a dedicated slot.

Table 12 Hardware Controller Options (*continued*)

Product ID (PID)	PID Description
Controllers for External Drives	
UCSC-9500-8E-D	9500 Series PCIe Gen 4.0 Tri-Mode Storage HBA 12Gb/s SAS/SATA/PCIe (NVMe) <ul style="list-style-type: none"> ■ External Storage HBA plugs in to PCIe slot ■ This controller is half-height half-length and can be installed in riser 1, 2, or 3.
Accessories/spare included with drive controller (For UCSC-C240-M7SX): <ul style="list-style-type: none"> ■ CBL-SAS12-C240M7, CBL-SAS24-C240M7 and UCSC-RDBKT-24XM7 are included with the selection of UCSC-SAS-T-D drive controller. ■ CBL-SDSAS-C240M7, CBL-SCAPSD-C240-D, CBL-SCAP-C240-D and UCSC-SDBKT-24XM7 are included with the selection of UCSC-RAID-SD-D drive controller ■ CBL-SAS-Y-C240M7, CBL-SCAPSD-C240-D, CBL-SCAP-C240-D and UCSC-HPBKT-24XM7 are included with the selection of UCSC-RAID-HP drive controller. <p>NOTE: If you are adding drive controller later as spare, you may need to order cables/supercap/super cables and controllers bracket with it.</p>	

Notes:

1. Available post first customer ship (FCS).
2. For Tri-Mode 24G SAS RAID Controller (UCSC-RAID-HP) please select one of the two RAID settings:

UCSC-RAID-SASSATA	Controller limited to SAS/SATA RAID
UCSC-RAID-NVMe	Controller limited to NVMe RAID

- If NVMe RAID is selected:

For front slots:

- Max 24 U.3 NVMe are allowed for NVMe RAID
- Max 4 U.2 NVMe are allowed as passthrough (*slots 1-4*)
- No SAS/SATA drives are allowed

For rear storage risers (if selected):

- Max 4 U.2 or U.3 NVMe are allowed as passthrough
- No SAS/SATA drives are allowed

2. If SAS/SATA RAID is selected:

For front slots:

- Max 4 U.2 or U.3 NVMe are allowed as passthrough (*slots 1-4*)
- Max 24 SAS/SATA drives are allowed

For rear storage risers (if selected):

- Max 4 U.2 or U.3 NVMe are allowed
- Max 4 SAS/SATA drives are allowed
- No mixing of NVMe and SAS/SATA are allowed

RAID Configuration Option

Select one of the RAID Configuration option from the following [Table 1](#).



CAUTION: All RAID options require drives of same sector size and media type. The smallest drive capacity will be used to calculate the RAID volume size.

Table 1 RAID Configuration Options

Product ID (PID)	PID Description
NOTE: Not available for Cisco 12G SAS HBA	
R2XX-SRAID0D	Enable single disk RAID 0 Setting.
R2XX-RAID0D	Factory preconfigured RAID striping option Enable RAID 0 Setting. Requires two or more drive.
R2XX-RAID00D	Factory preconfigured RAID striping option Enable RAID 00 Setting. Requires two or more drive.
R2XX-RAID1D	Factory preconfigured RAID mirroring option Enable RAID 1 Setting. Requires even number of drives (minimum of two).
R2XX-RAID5D	Factory preconfigured RAID option Enable RAID 5 Setting. Requires a minimum of three drives
R2XX-RAID6D	Factory preconfigured RAID option Enable RAID 6 Setting. Requires a minimum of four drives.
R2XX-RAID10D	Factory preconfigured RAID option Enable RAID 10 Setting. Requires even number of drives (minimum of 2 drives per span)
R2XX-RAID50D	Factory preconfigured RAID option Enable RAID 50 Setting. Requires minimum of three drives per span
R2XX-RAID60D	Factory preconfigured RAID option Enable RAID 60 Setting. Requires minimum of four drives per span.

Approved Configurations

Cisco UCS C240 M7 SFF server can be ordered as follows:

- UCSC-C240 M7SX (24-drive SAS/SATA/NVMe backplane and optionally 4 of those can be direct-attach NVMe)
- UCSC-C240-M7SN (24-drive direct-attach NVMe only)
- There is no RAID support for direct-attach NVMe drives.

STEP 6 SELECT DRIVES (OPTIONAL)

The standard disk drive features are:

- 2.5-inch small form factor (SFF)
- Hot-pluggable
- Drives come mounted in sleds

Select Drives

- The available NVMe SSDs drives for UCSC-C240-M7SN and UCSC-C240-M7SX are listed in [Table 2](#)
- The available SAS/SATA SSDs and HDDs drives for UCSC-C240-M7SX listed [Table 3](#)



CAUTION: Cisco uses solid state drives (SSDs) from a number of vendors. All solid state drives (SSDs) are subject to physical write limits and have varying maximum usage limitation specifications set by the manufacturer. Cisco will not replace any solid state drives (SSDs) that have exceeded any maximum usage specifications set by Cisco or the manufacturer, as determined solely by Cisco.

Table 2 Available NVMe drives for UCSC-C240-M7SN and UCSC-C240-M7SX (for front and rear)

Product ID (PID)	PID Description	Drive Type	Form Factor	Capacity
PCIe/NVMe SFF (2.5-inch) SFF drives				
UCS-NVMEXP-I400-D	400GB 2.5in U.2 Intel P5800X Optane NVMe Extreme Perform SSD	NVMe	U.2	400 GB
UCS-NVMEXP-I800-D	800GB 2.5in U.2 Intel P5800X Optane NVMe Extreme Perform SSD	NVMe	U.2	800 GB
UCS-NVME4-1600-D	1.6TB 2.5in U.2 P5620 NVMe High Perf High Endurance	NVMe	U.2	1.6 TB
UCS-NVME4-1920-D	1.9TB 2.5in U.2 P5520 NVMe High Perf Medium Endurance	NVMe	U.2	1.9 TB
UCS-NVME4-3200-D	3.2TB 2.5in U.2 P5620 NVMe High Perf High Endurance	NVMe	U.2	3.2 TB
UCS-NVME4-3840-D	3.8TB 2.5in U.2 P5520 NVMe High Perf Medium Endurance	NVMe	U.2	3.8 TB
UCS-NVME4-6400-D	6.4TB 2.5in U.2 P5620 NVMe High Perf High Endurance	NVMe	U.2	6.4 TB
UCS-NVME4-7680-D	7.6TB 2.5in U.2 P5520 NVMe High Perf Medium Endurance	NVMe	U.2	7.6 TB
UCS-NVME4-15360-D	15.3TB 2.5in U.2 P5520 NVMe High Perf Medium Endurance	NVMe	U.2	15.3 TB
UCS-NVMEQ-1536-D	15.3TB 2.5in U.2 P5316 NVMe High Perf Low Endurance	NVMe	U.2	15.3 TB
UCS-NVMEG4-M960-D ^{1,2}	960GB 2.5in U.3 Micron P7450 NVMe High Perf Medium Endurance	NVMe	U.3	960 GB
UCS-NVMEG4-M1920D ^{1,2}	1.9TB 2.5in U.3 Micron P7450 NVMe High Perf Medium Endurance	NVMe	U.3	1.9 TB

Table 2 Available NVMe drives (continued) for UCSC-C240-M7SN and UCSC-C240-M7SX (for front and

Product ID (PID)	PID Description	Drive Type	Form Factor	Capacity
UCS-NVMEG4-M3840D ^{1,2}	3.8TB 2.5in U.3 Micron P7450 NVMe High Perf Medium Endurance	NVMe	U.3	3.8 TB
UCS-NVMEG4-M7680D ^{1,2}	7.6TB 2.5in U.3 Micron P7450 NVMe High Perf Medium Endurance	NVMe	U.3	7.6 TB
UCS-NVMEG4-M1536D ^{1,2}	15.3TB 2.5in U.3 Micron P7450 NVMe High Perf Medium Endurance	NVMe	U.3	15.3 TB
UCS-NVMEG4-M1600D ^{1,2}	1.6TB 2.5in U.3 Micron P7450 NVMe High Perf High Endurance	NVMe	U.3	1.6 TB
UCS-NVMEG4-M3200D ^{1,2}	3.2TB 2.5in U.3 Micron P7450 NVMe High Perf High Endurance	NVMe	U.3	3.2 TB
UCS-NVMEG4-M6400D ^{1,2}	6.4TB 2.5in U.3 Micron P7450 NVMe High Perf High Endurance	NVMe	U.3	6.4 TB

Notes:

1. Available post first customer ship (FCS)
2. Only U.3 drives are allowed with RAID 24G Tri-mode RAID Controller and NVMe Hardware RAID.

Table 3 Available SAS/SATA SSD and HDDs for UCSC-C240-M7SX (for front and rear)

Product ID (PID)	PID Description	Drive Type	Capacity
HDDs			
HDDs (10K RPM)			
UCS-HD300G10KJ4-D	300 GB 12G SAS 10K RPM SFF HDD	SAS	300 GB
UCS-HD600G10KJ4-D	600 GB 12G SAS 10K RPM SFF HDD	SAS	600 GB
UCS-HD12TB10KJ4-D	1.2 TB 12G SAS 10K RPM SFF HDD	SAS	1.2 TB
UCS-HD18TB10KJ4-D	1.8 TB 12G SAS 10K RPM SFF HDD (4K)	SAS	1.8 TB
UCS-HD24TB10KJ4-D	2.4 TB 12G SAS 10K RPM SFF HDD (4K)	SAS	2.4 TB
Enterprise Performance SAS/SATA SSDs (High endurance, supports up to 10X or 3X DWPD (drive writes per day))			
SATA			
UCS-SD480G63XEP-D	480 GB 2.5in Enterprise Performance 6G SATA SSD(3X endurance)	SATA	480 GB
UCS-SD480GM3XEP-D	480 GB 2.5in Enterprise Performance 6G SATA SSD(3X endurance)	SATA	480 GB
UCS-SD960G63XEP-D	960 GB 2.5in Enterprise performance 6G SATA SSD(3X endurance)	SATA	960 GB
UCS-SD960GM3XEP-D	960 GB 2.5in Enterprise performance 6G SATA SSD(3X endurance)	SATA	960 GB
UCS-SD19T63X-EP-D	1.9 TB 2.5in Enterprise performance 6G SATA SSD(3X endurance)	SATA	1.9 TB
UCS-SD19TM3X-EP-D	1.9 TB 2.5in Enterprise performance 6G SATA SSD(3X endurance)	SATA	1.9 TB
UCS-SD38T63X-EP-D	3.8 TB 2.5in Enterprise performance 6G SATA SSD(3X endurance)	SATA	3.8 TB
UCS-SD480GBM3XEPD	480GB SATA SSD 3DWPD	SATA	480 GB
UCS-SD960GBM3XEPD	960GB SATA SSD 3DWPD	SATA	960 GB
UCS-SD19TBM3XEP-D	1.9TB SATA SSD 3DWPD	SATA	1.9 TB
SAS			
UCS-SD800GK3XEP-D	800 GB 2.5in Enterprise Performance 12G SAS SSD(3X endurance)	SAS	800 GB
UCS-SD800GS3XEP-D	800 GB 2.5in Enterprise Performance 12G SAS SSD(3X endurance)	SAS	800 GB

Table 3 Available SAS/SATA SSD and HDDs (continued)for UCSC-C240-M7SX (for front and rear)

Product ID (PID)	PID Description	Drive Type	Capacity
UCS-SD16TK3X-EP-D	1.6 TB 2.5in Enterprise Performance 12G SAS SSD(3X endurance)	SAS	1.6 TB
UCS-SD16TS3X-EP-D	1.6 TB 2.5in Enterprise Performance 12G SAS SSD(3X endurance)	SAS	1.6 TB
UCS-SD32TK3X-EP-D	3.2 TB 2.5in Enterprise Performance 12G SAS SSD(3X endurance)	SAS	3.2 TB
UCS-SD32TS3X-EP-D	3.2 TB 2.5in Enterprise Performance 12G SAS SSD(3X endurance)	SAS	3.2 TB
UCS-SD16TKA3XEP-D	1.6TB 2.5in Enterprise Performance 12G SAS SSD(3X endurance)	SAS	1.6 TB
UCS-SD32TKA3XEP-D	3.2TB 2.5in Enterprise Performance 12G SAS SSD(3X endurance)	SAS	3.2 TB
Enterprise Value SAS/SATA SSDs (Low endurance, supports up to 1X DWPD (drive writes per day))			
SATA			
UCS-SD240GM1XEV-D	240GB 2.5 inch Enterprise Value 6G SATA SSD	SATA	240 GB
UCS-SD480GM1XEV-D	480 GB 2.5 inch Enterprise Value 6G SATA SSD	SATA	480 GB
UCSSD480G6I1XEV-D	480GB 2.5 inch Enterprise Value 6G SATA SSD	SATA	480 GB
UCSSD960G6S1XEV-D	960GB 2.5 inch Enterprise Value 6G SATA SSD	SATA	960 GB
UCSSD960G6I1XEV-D	960GB 2.5 inch Enterprise Value 6G SATA SSD	SATA	960 GB
UCS-SD960GM1XEV-D	960GB 2.5 inch Enterprise Value 6G SATA SSD	SATA	960 GB
UCS-SD16TM1X-EV-D	1.6TB 2.5 inch Enterprise Value 6G SATA SSD	SATA	1.6 TB
UCS-SD19T6S1XEV-D	1.9TB 2.5 inch Enterprise Value 6G SATA SSD	SATA	1.9 TB
UCS-SD19TM1X-EV-D	1.9TB 2.5 inch Enterprise Value 6G SATA SSD	SATA	1.9 TB
UCS-SD38T6S1XEV-D	3.8 TB 2.5 inch Enterprise Value 6G SATA SSD	SATA	3.8 TB
UCS-SD38TM1X-EV-D	3.8 TB 2.5 inch Enterprise Value 6G SATA SSD	SATA	3.8 TB
UCS-SD38T6I1XEV-D	3.8TB 2.5 inch Enterprise Value 6G SATA SSD	SATA	3.8 TB
UCS-SD76T6S1XEV-D	7.6TB 2.5 inch Enterprise Value 6G SATA SSD	SATA	7.6 TB
UCS-SD76TM1X-EV-D	7.6TB 2.5 inch Enterprise Value 6G SATA SSD	SATA	7.6 TB
UCS-SD240GBM1XEVD	240GB SATA SSD 1DWPD	SATA	240 GB
UCS-SD480GBM1XEVD	480GB SATA SSD 1DWPD	SATA	480 GB
UCS-SD960GBM1XEVD	960GB SATA SSD 1DWPD	SATA	960 GB
UCS-SD16TBM1XEV-D	1.6GB SATA SSD 1DWPD	SATA	1.6 TB
UCS-SD19TBM1XEV-D	1.9TB SATA SSD 1DWPD	SATA	1.9 TB
UCS-SD38TBM1XEV-D	3.8TB SATA SSD 1DWPD	SATA	3.8 TB
UCS-SD76TBM1XEV-D	7.6TB SATA SSD 1DWPD	SATA	7.6 TB
SAS			
UCS-SD960GK1XEV-D	960GB 2.5 inch Enterprise Value 12G SAS SSD	SAS	960 GB
UCS-SD960GS1XEV-D	960GB 2.5 inch Enterprise Value 12G SAS SSD	SAS	960 GB
UCS-SD19TK1X-EV-D	1.9TB 2.5 inch Enterprise Value 12G SAS SSD	SAS	1.9 TB
UCS-SD19TS1X-EV-D	1.9TB 2.5 inch Enterprise Value 12G SAS SSD	SAS	1.9 TB
UCS-SD38TK1X-EV-D	3.8TB 2.5 inch Enterprise Value 12G SAS SSD	SAS	3.8 TB
UCS-SD38TS1X-EV-D	3.8TB 2.5 inch Enterprise Value 12G SAS SSD	SAS	3.8 TB
UCS-SD76TK1X-EV-D	7.6TB 2.5 inch Enterprise Value 12G SAS SSD	SAS	7.6 TB
UCS-SD15TK1X-EV-D	15.3TB 2.5 inch Enterprise Value 12G SAS SSD	SAS	15.3 TB

Table 3 Available SAS/SATA SSD and HDDs (continued)for UCSC-C240-M7SX (for front and rear)

Product ID (PID)	PID Description	Drive Type	Capacity
UCS-SD19TKA1XEVD	1.9TB 2.5 inch Enterprise Value 12G SAS SSD	SAS	1.9 TB
UCS-SD38TKA1XEVD	3.8TB 2.5 inch Enterprise Value 12G SAS SSD	SAS	3.8 TB
UCS-SD76TKA1XEVD	7.6TB 2.5 inch Enterprise Value 12G SAS SSD	SAS	7.6 TB
UCS-SD15TKA1XEVD	15.3TB 2.5 inch Enterprise Value 12G SAS SSD	SAS	15.3 TB
Self-Encrypted Drives (SED) (1X or 3X)			
SATA			
UCSSD960GBM2NK9-D	960GB Enterprise value SATA SSD (1X, SED) Non FIPS	SATA	960 GB
UCSSD19TBEM2NK9-D	1.9TB Enterprise value SATA SSD (1X , SED) Non FIPS	SATA	1.9 TB
UCSSD38TBEM2NK9-D	3.8TB Enterprise value SATA SSD (1X, SED) Non FIPS	SATA	3.8 TB
UCSSD76TBEM2NK9-D	7.6TB Enterprise value SATA SSD (1X, SED) Non FIPS	SATA	7.6 TB
SAS			
UCS-SD800GBKNK9-D	800GB Enterprise Performance SAS SSD (3X DWPD, SED) FIPS140-2	SAS	800 GB
UCS-SD960GBKNK9-D	960GB Enterprise Value SAS SSD (1X DWPD, SED) FIPS140-2	SAS	960 GB
UCS-SD16TBKNK9-D	1.6TB Enterprise performance SAS SSD (3X DWPD, SED) FIPS140-2	SAS	1.6 TB
UCS-SD38TBKNK9-D	3.8TB Enterprise Value SAS SSD (1X DWPD, SED) FIPS140-2	SAS	3.8 TB
UCS-SD76TBKNK9-D	7.6TB Enterprise value SAS SSD (1X DWPD, SED-FIPS) FIPS140-2	SAS	7.6 TB
UCS-SD16TBKANK9-D	1.6TB 2.5" Enterprise performance 12GSAS SSD(3DWPD,SED-FIPS) FIPS140-2	SAS	1.6 TB
UCS-SD38TBKANK9-D	3.8TB 2.5" Enterprise value 12G SAS SSD (1DWPD, SED-FIPS) FIPS140-2	SAS	3.8 TB
UCS-SD76TBKANK9-D	7.6TB Enterprise value SAS SSD (1DWPD, SED-FIPS) FIPS140-2	SAS	7.6 TB
UCS-SD960GM2NK9-D ¹	960GB SED SSD 1DWPD	SAS	960 GB
UCS-SD19TEM2NK9-D ¹	1.9TB SED SSD 1DWPD	SAS	1.9 TB
UCS-SD38TEM2NK9-D ¹	3.8TB SED SSD 1DWPD	SAS	3.8 TB
UCS-SD76TEM2NK9-D ¹	7.6TB SED SSD 1DWPD	SAS	7.6 TB
Accessories/spare included with drives (For UCSC-C240-M7SX):			
<ul style="list-style-type: none"> ■ When you order 1-2 front-facing direct-attach NVMe drives with or without raid controller (UCSC-RAID-SD-D or UCSC-RAID-HP), an NVMe cable (PID: CBL-NVME-C240M7) is included along with the drives. ■ When you order 3-4 front-facing direct-attach NVMe drives with or without raid controller (UCSC-RAID-SD-D or UCSC-RAID-HP), an NVMe cable (PID: CBL-FNVME-C240M7) is included along with the drives. ■ UCSC-BBLKD-M7 is included for the unselected front and rear storage device. 			
NOTE: If you decide to add front-facing NVMe drives later, you may need to order the drives as spare and also an NVMe cable (PID: CBL-NVME-C240M7= or CBL-FNVME-C240M7=). Spare NVMe cables supports depends on the drive controller installing/installed in the system.			

Notes:

1. Available post first customer ship (FCS).

Caveats

For UCSC-C240-M7SX:

- Front SFF NVMe drives 1-2 are connected directly to CPU1.
- Front SFF NVMe drives 3-4 are connected directly to CPU2.
- The rear NVMe drives are controlled directly from the CPUs.
- If you order 3 or 4 NVMe drives, you must also order two CPUs
- SFF NVMe drives are bootable in UEFI mode only.
- You can mix HDDs and SSDs as long as you keep all HDDs in their own RAID volume and all SSDs in their own RAID volume.
- You can mix SAS HDDs and SAS/SATA SSDs when using a Cisco M6 12G SAS RAID controller or Cisco 24G Tri-Mode RAID controller or Cisco 12G SAS HBA.
- SED drives can be mixed with the non-SED drives in [Table 3 on page 31](#)
- Rear NVMe drives in riser 1B are connected directly to CPU1
- Rear NVMe drives in riser 3B are connected directly to and require CPU 2
- Rear SAS/SATA drives in riser 1B or 3B connect to RAID or HBA Controllers.
- Drives behind the tri-mode controller must be either all SAS/SATA or all NVMe U.3

STEP 7 SELECT PCIe CARD(s) (OPTIONAL)

For up-to-date server compatibility, please check the Hardware and Software compatibility list (HCL) at <https://ucshcltool.cloudapps.cisco.com/public/>.

The standard PCIe card offerings are:

- Modular LAN on Motherboard (mLOM)
- Open Compute Project (OCP)
- Virtual Interface Cards (VICs)
- Network Interface Cards (NICs)
- Host Bus Adapters (HBAs)

Select Option Cards

The available option cards are listed in [Table 4](#).

Table 4 Available PCIe Option Cards

Product ID (PID)	PID Description	Location	Card Size ¹
Modular LAN on Motherboard (mLOM)			
UCSC-M-V5Q50G-D	Cisco UCS VIC 15428 Quad Port 10/25G/50G CNA MLOM	mLOM	HHHL, SS
UCSC-M-V5D200G-D	Cisco UCS VIC 15238 Dual Port 40/100/200G CNA MLOM	mLOM	HHHL, SS
Open Compute Project (OCP)			
UCSC-O-ID10GC-D ²	Intel X710T2LOCPV3G1L 2x10GbE RJ45 OCP 3.0 NIC	OCP	SFF
Virtual Interface Cards (VICs)			
UCSC-P-V5Q50G-D	Cisco UCS VIC 15425 Quad Port 10/25/50G CNA PCIE	Riser 1 or 2	HHHL, SS
UCSC-P-V5D200G-D	Cisco UCS VIC 15235 Dual Port 40/100/200G CNA PCIE	Riser 1 or 2	HHHL, SS
Network Interface Cards (NICs)			
1GB NICs			
UCSC-P-IQ1GC	Cisco-Intel I710-T4L 4x1GBASE-T NIC	Riser 1, 2, or 3	HHHL, SS
10GB NICs			
UCSC-PCIEID10GF-D	Intel X710-DA2 Dual Port 10Gb SFP+ NIC	Riser 1, 2, or 3	HHHL, SS
UCSC-PCIEIQ10GF-D	Intel X710 quad-port 10G SFP+ NIC	Riser 1, 2, or 3	HHHL, SS
UCSC-P-ID10GC-D	Cisco-Intel X710T2LG 2x10GBE RJ45 PCIe NIC	Riser 1, 2, or 3	HHHL, SS
UCSC-P-IQ10GC-D	Cisco-Intel X710T4LG 4x10GBE RJ45 PCIe NIC	Riser 1, 2, or 3	HHHL, SS
25GB NICs			
UCSC-P-I8D25GF-D ³	Cisco-Intel E810XXVDA2 2x25/10GBE SFP28 PCIe NIC	Riser 1, 2, or 3	HHHL, SS
UCSC-P-I8Q25GF-D ³	Cisco-Intel E810XXVDA4L 4x25/10GBE SFP28 PCIe NIC	Riser 1, 2, or 3	FHHL, SS
100GB NICs			
UCSC-P-MCD100GF-D ^{3,4}	Cisco-MLNX MCX623106AC-CDAT 2x100GbE QSFP56 PCIe NIC (with Crypto)	Riser 1, 2, or 3	HHHL, SS
UCSC-P-MDD100GF-D ^{3,4}	Cisco-MLNX MCX623106AS-CDAT 2x100GbE QSFP56 PCIe NIC	Riser 1, 2, or 3	HHHL, SS

Table 4 Available PCIe Option Cards (continued)

Product ID (PID)	PID Description	Location	Card Size ¹
UCSC-P-I8D100GF-D ^{3,4}	Cisco-Intel E810CQDA2 2x100 GbE QSFP28 PCIe NIC	Riser 1, 2, or 3	HHHL, SS
Host Bus Adapters (HBAs)			
UCSC-P-Q6D32GF-D	Cisco-QLogic QLE2772 2x32GFC Gen 6 Enhanced PCIe HBA	Riser 1, 2, or 3	HHHL, SS
UCSC-P-B7D32GF-D	Cisco-Emulex LPe35002-M2-2x32GFC Gen 7 PCIe HBA	Riser 1, 2, or 3	HHHL, SS
UCSC-PCIEQD16GF-D	QLogic QLE2692 dual-port 16G FC HBA	Riser 1, 2, or 3	HHHL, SS
UCSC-PCIEBD16GF-D	Emulex LPe31002 dual port 16G FC HBA	Riser 1, 2, or 3	HHHL, SS
UCSC-P-Q7D64GF	Cisco-QLogic QLE2872, 2x64GFC Gen 7 PCIe HBA	Riser 1, 2, or 3	HHHL, SS
External Storage HBA			
UCSC-9500-8E-D	Cisco 12G 9500-8e 12G SAS HBA for external JBOD attach	Riser 1, 2, or 3	HHHL, SS
Accessories/spare included with PCI Card:			
<ul style="list-style-type: none"> ■ UCSC-OCP3-KIT-D is included along with the selection UCSC-O-ID10GC-D card 			

Notes:

1. HHHL = half-height, half-length; FHHL = full-height, half-length; SS = single-slot; DS = double-slot. SFF = small form factor.
2. For installation in the mLOM slot, you can order either an mLOM VIC, or the OCP NIC - but not both. If ordering the OCP NIC, the OCP Mechanical Kit (UCSC-OCP3-KIT-D) must also be installed in order to mount OCP NIC in the mLOM slot.
3. When present, the recommended Fan Speed Control policy setting is balanced.
4. NICs with 16 active electrical lanes, such as the 100G NICs, can be inserted in slots with 8 active electrical lanes. The NIC will function but may exhibit degraded performance.

Caveats

- For 1-CPU systems:
 - All the PCIe slots on riser 1A and 1C are supported for the PCIe Cards.
 - Riser 2 and 3 are not supported in 1-CPU system.
 - Only a single plug-in PCIe VIC card may be installed on a 1-CPU system, and it must be installed in slots 1 or 2 of riser 1A or slot 1 of riser 1C.
 - You can order an mLOM VIC card to be installed in the mLOM/OCP 3.0 slot internal to the chassis and thus have two VIC cards in operation at the same time. If you order a double-width GPU, it must be installed in slot 2; then a PCIe VIC can be installed in slot 1. See the [Table 4 on page 35](#) for the selection of plug-in and mLOM/OCP 3.0 VIC cards.
- For 2-CPU systems:
 - All the PCIe slots on riser 1, 2, and 3 are supported for the PCIe Cards.
 - You can order an mLOM VIC card to be installed in the mLOM slot internal to the chassis. You can also have up to two PCIe VICs.
 - If Riser 1A and 2A are selected, two PCIe VIC can be installed in slot 2 of Riser 1A and slot 5 of Riser 2A. If GPUs are installed in slot 2 of riser 1A or slot 5 of riser 2A, the NCSI capability automatically switches over to slot 1 of riser 1A or slot 4 of Riser 2A. Therefore, Cisco PCIe VICs can be installed in slot 1 of Riser 1A and slot 4 of Riser 2A if GPUs are installed in slots 2 of Riser 1A and slot 5 of Riser 2A.

- If Riser 1C and 2C are selected, two PCIe VIC and be installed in slot 1 of Riser 1C and slot 4 of Riser 2C.

See [Table 5 on page 38](#) for the selection of plug-in and mLOM VIC cards. See also [C240 M7 Server With Top Cover Off, page 57](#) and below table for the PCIe slot physical descriptions.

- The server supports up to two PCIe Cisco VICs plus an MLOM VIC. However, single wire management is supported on only one VIC at a time. If multiple VICs are installed on a server, only one slot has NCSI enabled at a time and for single wire management, priority goes to the MLOM slot, then slot 2 of riser 1A/slot 1 of riser 1C, then slot 5 of riser 2A/slot 4 of riser 2C for NCSI management traffic. When multiple cards are installed, connect the single wire management cables in the priority order mentioned above.
- For installation in the mLOM slot, you can order either an mLOM VIC, or the OCP NIC - but not both. If ordering the OCP NIC, the OCP Mechanical Kit (UCSC-OCP3-KIT) must also be installed in order to mount OCP NIC in the mLOM slot.



NOTE:

- UCSM managed servers are discoverable only if a PCIe VIC is installed or a VIC is installed in the MLOM slot.
- To help ensure that your operating system is compatible with the card you have selected, or to see additional cards that have been qualified to work with the UCS C240 M7 server, but are not sold on the Cisco price list, check the [Hardware Compatibility List](#) link.

ORDER OPTIONAL PCIe OPTION CARD ACCESSORIES

- At the time of first launch, the 3rd Party Ethernet adapters were tested for interoperability with an initial selection of Optical Modules and Cables. Please check the Product Briefs for this initial list of interoperable optics and cables at <https://www.cisco.com/c/en/us/products/servers-unified-computing/third-party-adapters-listing.html>.
- For list of supported optics and cables for VIC 15428 and VIC 15238, refer to the VIC 15000 series data sheet at <https://www.cisco.com/c/en/us/products/collateral/interfaces-modules/unified-computing-system-adapters/ucs-vic-15000-series-ds.htm>
- Cisco Transceiver Module Group (TMG) conducts tests with Cisco optics and cables and publishes the results in the TMG Compatibility Matrix. The latest compatibility with optical modules and DACs can be found at <https://tmgmatrix.cisco.com/>
- Refer to the these links for additional connectivity options.

Intel:

[Product Guide](#)

[Speed White Paper](#)

STEP 8 ORDER GPU CARDS (OPTIONAL)

Select GPU Options

The available GPU PCIe options and their riser slot compatibilities are listed in [Table 5](#).



CAUTION: 256GB DIMMs cannot be combined with GPU cards, and the ambient temperature shall be limited to a maximum of 28°C.



NOTE:

- GPUs cannot be mixed
- All GPU cards must be procured from Cisco as there is a unique SBIOS ID required by CIMC and UCSM
- If a GPU with TDP equal or greater than 150W is ordered, all the 3 risers are required, and GPU airblocker will be installed in the middle slot of any empty riser in the system.
- If GPUs are installed in slot 2 of riser 1A/1C or slot 5 of riser 2A/2C, the NCSI capability automatically switches over to slot 1 of riser 1A/1C or slot 4 of Riser 2A/2C. Therefore, Cisco PCIe VICs can be installed in slots 1 and 4, if GPUs are installed in slots 2 and 5. If you order multiple GPUs, they must be installed as shown in [Table 5 on page 38](#).
- Please refer to [installation guide](#) for the installation of the GPUs.

Table 5 Available PCIe GPU Cards

GPU Product ID (PID)	PID Description	Card Size	Max GPU Per Node	Riser Slot Compatibility ¹			
				Riser 1A/1C	Riser 2A/2C	Riser 3C ²	Riser 1B/3A/3B
UCSC-GPU-A30-D	TESLA A30, PASSIVE, 180W, 24GB	double-wide	3	slot 2	slot 5	slot 7	n/a
UCSC-GPU-A40-D	TESLA A40 RTX, PASSIVE, 300W, 48GB	double-wide	3	slot 2	slot 5	slot 7	n/a
UCSC-GPUA100-80-D	TESLA A100, PASSIVE, 300W, 80GB	double-wide	3	slot 2	slot 5	slot 7	n/a
UCSC-GPU-A16-D	NVIDIA A16 PCIE 250W 4X16GB	double-wide	3	slot 2	slot 5	slot 7	n/a
UCSC-GPU-FLEX170	Intel GPU Flex 170, Gen4x16, HHFL, 150W PCIe	Single-wide	3	slot 2 (Riser 1A Only)	slot 5 (Riser 2A Only)	slot 7	n/a
UCSC-GPU-FLEX140	Intel GPU Flex 140, Gen4x8, HHHL, 75W PCIe	Single-wide	5	slot 2&3 (Riser 1A Only)	slot 5&6 (Riser 2A Only)	slot 7	n/a

Table 5 Available PCIe GPU Cards

GPU Product ID (PID)	PID Description	Card Size	Max GPU Per Node	Riser Slot Compatibility ¹			
UCSC-GPU-H100-80	NVIDIA H100: 350W, 80GB, 2-slot FHFL GPU	double-wide	2	slot 2 (Riser 1C Only)	slot 5 (Riser 2C Only)	n/a	n/a
UCSC-GPU-L40	NVIDIA L40: 300W, 48GB, 2-slot FHFL GPU	double-wide	3	slot 2	slot 5	slot 7	n/a
UCSC-GPU-L4	NVIDIA L4:70W, 24GB, 1-slot HHHH GPU	Single-wide	8	All slots	All slots	slot 7	slot 7

Accessories/spare included with GPU:

- When a GPU ready configuration is ordered, the server comes with low-profile heatsinks PID (UCSC-HSLP-C220M7), and special airblocker PID (UCSC-RISAB-24XM7) for GPUs.
- Air duct (UCSC-GPUAD-C240M7) is **not** auto-included with the double wide GPUs, however it is required selection under configuration.
- UCS-P100CBL-240-D is included with the selection of A100/A40/A16/A30 GPUs.
- UCS-M10CBL-C240M7 power cable included with the selection of FLEX170 GPU.
- CBL-G5GPU-C240M7 power cable included with the selection of UCSC-GPU-H100-80 GPU.
- CBL-L40GPU-C240M7 Power cable included with the selection of UCSC-GPU-L40 GPU.

NOTE: If you are adding GPUs later to non-GPU ready configuration system, you may need to order the GPU airblocker on any empty risers in the system, GPU airduct, low profile heatsinks and cables needed along with the spare GPU.

Notes:

1. 1C and 2C are Gen 5 riser and 1A and 2A are Gen 4 riser.
2. The server supports one full-height, full-length, double-wide GPU (PCIe slot 7 only) in Riser 3C.

Table 6 NVIDIA GPU Licenses

Product ID (PID)	PID Description
NV-GRDWK-1-D5S	Quadro Perpetual Lic - NVIDIA vDWS 1CCU; 5Yr SUMS Req
NV-GRDVA-1-D5S	GRID Perpetual Lic - NVIDIA VDI APPs 1CCU; 5Yr SUMS Reqd
NV-GRDPC-1-D5S	GRID Perpetual Lic - NVIDIA VDI PC 1CCU; 5Yr SUMS Reqd
NV-GRD-EDP-D5S	EDU - Quadro Perpetual Lic - NVIDIA vDWS 1CCU; 5Yr SUMS Reqd
NV-GRID-WKP-D5YR	NVIDIA Quadro Production SUMS - vDWS 1CCU - 5 Year
NV-GRID-VAP-D5YR	NVIDIA GRID Production SUMS - VDI Apps 1CCU - 5 Year
NV-GRID-PCP-D5YR	NVIDIA GRID Production SUMS - VDI PC 1CCU - 5 Year
NV-GRID-EDP-D5YR	EDU - NVIDIA Quadro vDWS Production SUMS - 1CCU - 5 Year
NV-GRID-WKS-D1YR	NVIDIA Quadro SW Subscription - vDWS 1CCU - 1 Year
NV-GRID-WKS-D3YR	NVIDIA Quadro SW Subscription - vDWS 1CCU - 3 Year
NV-GRID-WKS-D4YR	NVIDIA Quadro SW Subscription - vDWS 1CCU - 4 Year

Table 6 NVIDIA GPU Licenses (*continued*)

Product ID (PID)	PID Description
NV-GRID-WKS-D5YR	NVIDIA Quadro SW Subscription - vDWS 1CCU - 5 Year
NV-GRID-PCS-D1YR	NVIDIA GRID Software Subscription - VDI PC 1CCU - 1 Year
NV-GRID-PCS-D3YR	NVIDIA GRID Software Subscription - VDI PC 1CCU - 3 Year
NV-GRID-PCS-D4YR	NVIDIA GRID Software Subscription - VDI PC 1CCU - 4 Year
NV-GRID-PCS-D5YR	NVIDIA GRID Software Subscription - VDI PC 1CCU - 5 Year
NV-GRID-VAS-D1YR	NVIDIA GRID Software Subscription - VDI Apps 1CCU - 1 Year
NV-GRID-VAS-D3YR	NVIDIA GRID Software Subscription - VDI Apps 1CCU - 3 Year
NV-GRID-VAS-D4YR	NVIDIA GRID Software Subscription - VDI Apps 1CCU - 4 Year
NV-GRID-VAS-D5YR	NVIDIA GRID Software Subscription - VDI Apps 1CCU - 5 Year
NV-GRID-EDS-D1YR	EDU - NVIDIA Quadro vDWS SW Subscription - 1CCU - 1 Year
NV-GRID-EDS-D3YR	EDU - NVIDIA Quadro vDWS SW Subscription - 1CCU - 3 Year
NV-GRID-EDS-D4YR	EDU - NVIDIA Quadro vDWS SW Subscription - 1CCU - 4 Year
NV-GRID-EDS-D5YR	EDU - NVIDIA Quadro vDWS SW Subscription - 1CCU - 5 Year
NV-VCS-D1Y	NVIDIA vCompute Server Subscription - 1 GPU - 1 Year
NV-VCS-D3Y	NVIDIA vCompute Server Subscription - 1 GPU - 3 Year
NV-VCS-D5Y	NVIDIA vCompute Server Subscription - 1 GPU - 5 Year

STEP 9 ORDER POWER SUPPLY (REQUIRED)

Power supplies share a common electrical and physical design that allows for hot-plug and tool-less installation into M7 C-series servers. Each power supply is certified for high-efficiency operation and offer multiple power output options. This allows users to “right-size” based on server configuration, which improves power efficiency, lower overall energy costs and avoid stranded capacity in the data center.

Use the power calculator at the following link to determine the needed power based on the options chosen (CPUs, drives, memory, and so on):

<http://ucspowercalc.cisco.com>

Table 7 Power Supply

Product ID (PID)	PID Description
PSU (Input High Line 210VAC)	
UCSC-PSUV21050D-D	1050W DC power supply for C-Series servers Platinum
UCSC-PSU1-1200W-D	1200W Titanium power supply for C-Series Servers Titanium
UCSC-PSU1-1600W-D	1600W AC power supply for C-Series servers Platinum
UCSC-PSU1-2300W-D	2300W Power supply for C-series servers Titanium
PSU (Input Low Line 110VAC)	
UCSC-PSU1-1200W-D	1200W Titanium power supply for C-Series Servers Titanium
UCSC-PSU1-2300W-D	2300W Power supply for C-series servers Titanium



NOTE:

- In a server with two power supplies, both power supplies must be identical.
- Refer to *Power Specifications, page 88* section for the full details on the each power supply.

STEP 10 SELECT INPUT POWER CORD(S) (REQUIRED)

Using [Table 8](#) and [Table 9](#), select the appropriate AC power cords. You can select a minimum of no power cords and a maximum of two. If you select the option R2XX-DMYMPWRCORD, no power cord is shipped with the server.



NOTE: [Table 8](#) lists the power cords for servers that use power supplies less than 2300 W. [Table 9](#) lists the power cords for servers that use 2300 W power supplies. Note that the power cords for 2300 W power supplies use a C19 connector so they only fit the 2300 W power supply connector.

Table 8 Available Power Cords (for server PSUs less than 2300 W)

Product ID (PID)	PID Description	Images
NO-POWER-CORD	ECO friendly green option, no power cable will be shipped	
CAB-48DC40A8AWG-D	C-Series -48VDC PSU Power Cord, 3.5M, 3 Wire, 8AWG, 40A	<p>Figure 1-3 CAB-48DC-40A-8AWG, DC Power Cord (3.5 m)</p>
CAB-N5K6A-NA	Power Cord, 200/240V 6A, North America	<p>Plug: NEMA 6-15P Cordset rating: 10 A, 250 V Length: 8.2 ft Connector: IEC60320/C13</p>
CAB-AC-L620-C13-D	AC Power Cord, NEMA L6-20 - C13, 2M/6.5ft	
CAB-C13-CBN	CABASY,WIRE,JUMPER CORD, 27\" L, C13/C14, 10A/250V	<p>685 MM ± 25 MM 75MM±10MM SEE NOTE K3 PLUG TYPE: S13A (EC 200-2-2) CONNECTOR TYPE: M13S (EC 300 854H)</p>
CAB-C13-C14-2M	CABASY,WIRE,JUMPER CORD, PWR, 2 Meter, C13/C14,10A/250V	<p>2,000 1,100 1,200</p>

Table 8 Available Power Cords (for server PSUs less than 2300 W)

Product ID (PID)	PID Description	Images
CAB-C13-C14-AC	CORD,PWR,JMP,IEC60320/C14,IEC60320/C13, 3.0M	
CAB-250V-10A-AR	Power Cord, 250V, 10A, Argentina	
CAB-9K10A-AU	Power Cord, 250VAC 10A 3112 Plug, Australia	
CAB-250V-10A-CN	AC Power Cord - 250V, 10A - PRC	
CAB-9K10A-EU	Power Cord, 250VAC 10A CEE 7/7 Plug, EU	
CAB-250V-10A-ID	Power Cord, 250V, 10A, India	
CAB-C13-C14-3M-IN	Power Cord Jumper, C13-C14 Connectors, 3 Meter Length, India	Image not available
CAB-C13-C14-IN	Power Cord Jumper,C13-C14 Connectors,1.4 Meter Length, India	Image not available
CAB-250V-10A-IS	Power Cord, SFS, 250V, 10A, Israel	

Table 8 Available Power Cords (for server PSUs less than 2300 W)

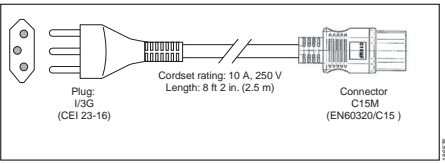
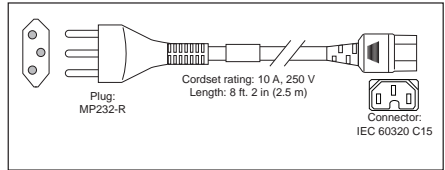
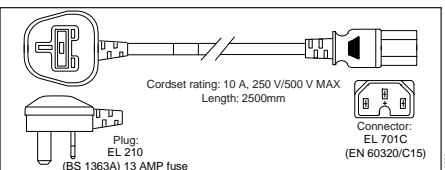
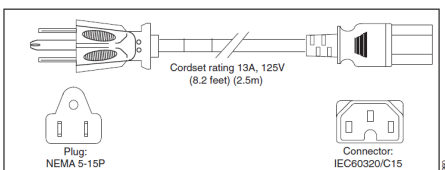
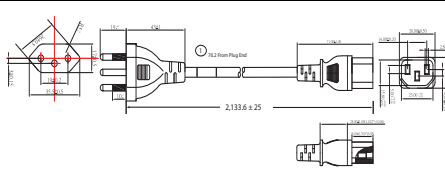
Product ID (PID)	PID Description	Images
CAB-9K10A-IT	Power Cord, 250VAC 10A CEI 23-16/VII Plug, Italy	
CAB-9K10A-SW	Power Cord, 250VAC 10A MP232 Plug, Switzerland	
CAB-9K10A-UK	Power Cord, 250VAC 10A BS1363 Plug (13 A fuse), UK	
CAB-9K12A-NA ¹	Power Cord, 125VAC 13A NEMA 5-15 Plug, North America	
CAB-250V-10A-BR	Power Cord - 250V, 10A - Brazil	
CAB-C13C142M-JP-D	Power Cord C13-C14, 2M/6.5ft Japan PSE mark	Image not available
CAB-9K10A-KOR ¹	Power Cord, 125VAC 13A KSC8305 Plug, Korea	Image not available
CAB-ACTW	AC Power Cord (Taiwan), C13, EL 302, 2.3M	Image not available
CAB-JPN-3PIN	Japan, 90-125VAC 12A NEMA 5-15 Plug, 2.4m	Image not available
CAB-48DC40A-INT-D	C-Series -48VDC PSU PWR Cord, 3.5M, 3 Wire, 8AWG, 40A (INT)	Image not available
CAB-48DC-40A-AS-D	C-Series -48VDC PSU PWR Cord, 3.5M, 3Wire, 8AWG, 40A (AS/NZ)	Image not available

Notes:

1. This power cord is rated to 125V and only supported for PSU rated at 1050W or less

Table 9 Available Power Cords (for servers with 2300 W PSUs)

Product ID (PID)	PID Description	Images
CAB-C19-CBN	Cabinet Jumper Power Cord, 250 VAC 16A, C20-C19 Connectors	Not applicable
CAB-S132-C19-ISRL	S132 to IEC-C19 14ft Israeli	Image not available
CAB-IR2073-C19-AR	IRSM 2073 to IEC-C19 14ft Argen	Image not available
CAB-BS1363-C19-UK	BS-1363 to IEC-C19 14ft UK	Image not available
CAB-SABS-C19-IND	SABS 164-1 to IEC-C19 India	Image not available
CAB-C2316-C19-IT	CEI 23-16 to IEC-C19 14ft Italy	Image not available
CAB-L520P-C19-US	NEMA L5-20 to IEC-C19 6ft US	Image not available
CAB-US515P-C19-US	NEMA 5-15 to IEC-C19 13ft US	Image not available
CAB-US520-C19-US	NEMA 5-20 to IEC-C19 14ft US	Image not available
CAB-US620P-C19-US	NEMA 6-20 to IEC-C19 13ft US	Image not available

STEP 11 ORDER TOOL-LESS RAIL KIT (REQUIRED) AND REVERSIBLE CABLE MANAGEMENT ARM (OPTIONAL)

■ Tool-less Rail Kit:

Select a tool-less rail kit (or no rail kit) from [Table 10](#).



NOTE:

- Cisco recommends a minimum quantity of 1 Rail Kit.
- If you plan to rackmount your UCS C240 M7 server, you must order a tool-less rail kit.

Table 10 Tool-less Rail Kit Options

Product ID (PID)	PID Description
UCSC-RAIL-D	Ball bearing rail kit
UCSC-RAIL-NONE-D	No rail kit option

■ Optional Reversible Cable Management Arm:

The reversible cable management arm mounts on either the right or left slide rails at the rear of the server and is used for cable management. Select an Optional Reversible Cable Management Arm from [Table 11](#).



NOTE: If you plan to rackmount your UCS C240 M7 server, you must order a tool-less rail kit. The same rail kits and CMAs are used for M6 and M7 servers.

Table 11 Cable Management Arm

Product ID (PID)	PID Description
UCSC-CMA-C240-D	Reversible CMA for ball bearing rail kit

For more information about the tool-less rail kit and cable management arm, check the [Cisco UCS C240 M7 Installation Guide](#).

STEP 12 SELECT MANAGEMENT CONFIGURATION (OPTIONAL)

By default, the C240 M7 server NIC mode is configured to be Shared LOM Extended. This NIC mode allows any LOM port or adapter card port to be used to access the Cisco Integrated.



NOTE:

- There are no LOM ports on the C220 and C240 M7 servers. Servers ordered without a VIC or OCP card will ship in Dedicated network mode, unless otherwise specified by a configurable SW PID (**UCSC-CCARD-01**)
- For full details on all the NIC mode settings, see

https://www.cisco.com/c/en/us/td/docs/unified_computing/ucs/c/hw/c220m6/install/c220m7/m_maintaining_the_server.html?bookSearch=true

Table 12 Management Configuration Ordering Information

Product ID (PID)	PID Description
UCSC-DLOM-01-D	Dedicated Mode BIOS setting for C-Series Servers <ul style="list-style-type: none"> ■ To change the default NIC mode to Dedicated NIC mode, select this card ■ In Dedicated NIC mode, the CIMC can be accessed only through the dedicated management port. ■ See <i>Chassis Rear View (UCSC-C240-M7SX)</i>, page 5 for the location of the management port
UCSC-CCARD-01-D	Cisco Card Mode BIOS setting for C-Series Servers <ul style="list-style-type: none"> ■ To change the default NIC mode to Cisco Card Mode, select this card ■ If Cisco card selected, a VIC or MLOM must also be included in the configuration. if OCP card is included in the configuration, a VIC card must be selected. ■ In this mode, you can assign an IP address to the CIMC using DHCP and from there you can fully automate your deployment.

In addition, the optional software PIDS listed in [Table 17 on page 51](#) can be ordered for setting the server to operate in various modes.

STEP 13 ORDER SECURITY DEVICES (REQUIRED)

A Trusted Platform Module (TPM) is a computer chip (microcontroller) that can securely store artifacts used to authenticate the platform (server). These artifacts can include passwords, certificates, or encryption keys. A TPM can also be used to store platform measurements that help ensure that the platform remains trustworthy. Authentication (ensuring that the platform can prove that it is what it claims to be) and attestation (a process helping to prove that a platform is trustworthy and has not been breached) are necessary steps to ensure safer computing in all environments.

A chassis intrusion switch gives a notification of any unauthorized mechanical access into the server.

The security device ordering information is listed in [Table 13](#)



NOTE:

- The TPM module used in this system conforms to TPM v1.2 and 2.0, as defined by the Trusted Computing Group (TCG). It is also SPI-based.
- TPM installation is supported after-factory. However, a TPM installs with a one-way screw and cannot be replaced, upgraded, or moved to another server. If a server with a TPM is returned, the replacement server must be ordered with a new TPM.

Table 13 Security Devices

Product ID (PID)	PID Description
UCSX-TPM-002C-D	Trusted Platform Module 2.0 for UCS servers
UCSC-INT-SW02-D	C220 and C240 M7 Chassis Intrusion Switch
UCSX-TPM-OPT-OUT-D	OPT OUT, TPM 2.0, TCG, FIPS140-2, CC EAL4+ Certified ¹

Notes:

1. Please note that Microsoft certification requires a TPM 2.0 for bare-metal or guest VM deployments. Opt-out of the TPM 2.0 voids the Microsoft certification

STEP 14 SELECT LOCKING SECURITY BEZEL (OPTIONAL)

An optional locking bezel can be mounted to the front of the chassis to prevent unauthorized access to the drives.

Select the locking bezel from [Table 14](#).

Table 14 Locking Bezel Option

Product ID (PID)	Description
UCSC-BZL-C240-D	C240 M7 Security Bezel

STEP 15 ORDER M.2 SATA SSDs (OPTIONAL)

- Order one or two matching M.2 SATA SSDs from [Table 15](#) along with a boot-optimized RAID controller (see [Table 16](#)). See [Figure 3 on page 57](#) for the location of the module connector on the motherboard. The motherboard connector accepts the extender board and the extender board accepts the boot-optimized RAID controller. Each boot-optimized RAID controller can accommodate up to two SATA M.2 SSDs.



NOTE:

- It is recommended that M.2 SATA SSDs be used as boot-only devices.
- Order one or two identical M.2 SATA SSDs for the boot optimized RAID controller
- You cannot mix M.2 SATA SSD capacities.

Table 15 M.2 SATA SSDs

Product ID (PID)	PID Description
UCS-M2-240GB-D	240GB M.2 SATA SSD
UCS-M2-960GB-D	960GB M.2 SATA SSD
UCS-M2-240G-D	240GB M.2 SATA SSD
UCS-M2-960G-D	960GB M.2 SATA SSD
UCS-M2-I240GB-D	240GB SATA M.2 SSD
UCS-M2-I480GB-D	480GB SATA M.2 SSD

- Order Cisco boot optimized M.2 RAID controller from [Table 16](#). The boot optimized RAID controller plugs into a extender board on the motherboard and holds up to two M.2 SATA drives.



NOTE:

- The Cisco boot optimized M.2 RAID controller supports VMWare, Windows and Linux Operating Systems
- The Cisco boot optimized M.2 RAID controller supports RAID 1 and JBOD mode
- The Cisco boot optimized M.2 RAID controller is available only with 240GB, 480GB, and 960GB M.2 SSDs.
- CIMC is supported for configuring of volumes and monitoring of the controller and installed SATA M.2 drives
- The SATA M.2 drives can boot in UEFI mode only. Legacy boot mode is not supported
- Hot-plug replacement is not supported. The server must be powered off.

Table 16 Boot-Optimized RAID Controller

Product ID (PID)	PID Description
UCS-M2-HWRAID-D	Cisco Boot optimized M.2 RAID controller (holds up to two M.2 SATA SSDs)
Accessories/spare included with Boot-Optimized RAID Controller: <ul style="list-style-type: none"> ■ UCSC-M2EXT-240-D is included with the selection of this Boot-Optimized RAID Controller. 	

STEP 16 SELECT OPERATING SYSTEM AND VALUE-ADDED SOFTWARE

Select

- Cisco Software ([Table 17](#))
- Operating System ([Table 18](#))



NOTE: See this link for operating system guidance:
<https://ucshcltool.cloudapps.cisco.com/public/>

Table 17 OEM Software

Product ID (PID)	PID Description
VMware vCenter	
VMW-VCS-STD-D1A	VMware vCenter 7 Server Standard, 1 yr support required
VMW-VCS-STD-D3A	VMware vCenter 7 Server Standard, 3 yr support required
VMW-VCS-STD-D5A	VMware vCenter 7 Server Standard, 5 yr support required
VMW-VCS-FND-D1A	VMware vCenter Server 7 Foundation (4 Host), 1 yr supp reqd
VMW-VCS-FND-D3A	VMware vCenter Server 7 Foundation (4 Host), 3 yr supp reqd
VMW-VCS-FND-D5A	VMware vCenter Server 7 Foundation (4 Host), 5 yr supp reqd

Table 18 Operating System

Product ID (PID)	PID Description
Microsoft Windows Server	
MSWS-22-ST16CD	Windows Server 2022 Standard (16 Cores/2 VMs)
MSWS-22-ST16CD-NS	Windows Server 2022 Standard (16 Cores/2 VMs) - No Cisco SVC
MSWS-22-DC16CD	Windows Server 2022 Data Center (16 Cores/Unlimited VMs)
MSWS-22-DC16CD-NS	Windows Server 2022 DC (16 Cores/Unlim VMs) - No Cisco SVC
MSWS-19-ST16CD	Windows Server 2019 Standard (16 Cores/2 VMs)
MSWS-19-ST16CD-NS	Windows Server 2019 Standard (16 Cores/2 VMs) - No Cisco SVC
MSWS-19-DC16CD	Windows Server 2019 Data Center (16 Cores/Unlimited VMs)
MSWS-19-DC16CD-NS	Windows Server 2019 DC (16 Cores/Unlim VMs) - No Cisco SVC
Red Hat	
RHEL-2S2V-D1A	Red Hat Enterprise Linux (1-2 CPU,1-2 VN); 1-Yr Support Req

Table 18 Operating System (continued)

Product ID (PID)	PID Description
RHEL-2S2V-D3A	Red Hat Enterprise Linux (1-2 CPU,1-2 VN); 3-Yr Support Req
RHEL-2S2V-D5A	Red Hat Enterprise Linux (1-2 CPU,1-2 VN); 5-Yr Support Req
RHEL-VDC-2SUV-D1A	RHEL for Virt Datacenters (1-2 CPU, Unlim VN) 1 Yr Supp Req
RHEL-VDC-2SUV-D3A	RHEL for Virt Datacenters (1-2 CPU, Unlim VN) 3 Yr Supp Req
RHEL-VDC-2SUV-D5A	RHEL for Virt Datacenters (1-2 CPU, Unlim VN) 5 Yr Supp Req
Red Hat Ent Linux/ High Avail/ Res Strg/ Scal	
RHEL-2S2V-D1S	Red Hat Enterprise Linux (1-2 CPU,1-2 VN); Prem 1Yr SnS Reqd
RHEL-2S2V-D3S	Red Hat Enterprise Linux (1-2 CPU,1-2 VN); Prem 3Yr SnS Reqd
RHEL-2S-HA-D1S	RHEL High Availability (1-2 CPU); Premium 1-yr SnS Reqd
RHEL-2S-HA-D3S	RHEL High Availability (1-2 CPU); Premium 3-yr SnS Reqd
RHEL-2S-RS-D1S	RHEL Resilent Storage (1-2 CPU); Premium 1-yr SnS Reqd
RHEL-2S-RS-D3S	RHEL Resilent Storage (1-2 CPU); Premium 3-yr SnS Reqd
RHEL-VDC-2SUV-D1S	RHEL for Virt Datacenters (1-2 CPU, Unlim VN) 1 Yr SnS Reqd
RHEL-VDC-2SUV-D3S	RHEL for Virt Datacenters (1-2 CPU, Unlim VN) 3 Yr SnS Reqd
Red Hat SAP	
RHEL-SAP-2S2V-D1S	RHEL for SAP Apps (1-2 CPU, 1-2 VN); Prem 1-Yr SnS Reqd
RHEL-SAP-2S2V-D3S	RHEL for SAP Apps (1-2 CPU, 1-2 VN); Prem 3-Yr SnS Reqd
RHEL-SAPSP-D3S	RHEL SAP Solutions Premium - 3 Years
RHEL-SAPSS-D3S	RHEL SAP Solutions Standard - 3 Years
VMware	
VMW-VSP-STD-D1A	VMware vSphere 7 Std (1 CPU, 32 Core) 1-yr, Support Required
VMW-VSP-STD-D3A	VMware vSphere 7 Std (1 CPU, 32 Core) 3-yr, Support Required
VMW-VSP-STD-D5A	VMware vSphere 7 Std (1 CPU, 32 Core) 5-yr, Support Required
VMW-VSP-EPL-D1A	VMware vSphere 7 Ent Plus (1 CPU, 32 Core) 1Yr, Support Reqd
VMW-VSP-EPL-D3A	VMware vSphere 7 Ent Plus (1 CPU, 32 Core) 3Yr, Support Reqd
VMW-VSP-EPL-D5A	VMware vSphere 7 Ent Plus (1 CPU, 32 Core) 5Yr, Support Reqd
SUSE	
SLES-2S2V-D1A	SUSE Linux Enterprise Svr (1-2 CPU,1-2 VM); 1-Yr Support Req
SLES-2S2V-D3A	SUSE Linux Enterprise Svr (1-2 CPU,1-2 VM); 3-Yr Support Req

Table 18 Operating System (*continued*)

Product ID (PID)	PID Description
SLES-2S2V-D5A	SUSE Linux Enterprise Svr (1-2 CPU,1-2 VM); 5-Yr Support Req
SLES-2SUVM-D1A	SUSE Linux Enterprise Svr (1-2 CPU,Unl VM) LP; 1Y Supp Req
SLES-2SUVM-D3A	SUSE Linux Enterprise Svr (1-2 CPU,Unl VM) LP; 3Y Supp Req
SLES-2SUVM-D5A	SUSE Linux Enterprise Svr (1-2 CPU,Unl VM) LP; 5Y Supp Req
SLES-2S-LP-D1A	SUSE Linux Live Patching Add-on (1-2 CPU); 1yr Support Req
SLES-2S-LP-D3A	SUSE Linux Live Patching Add-on (1-2 CPU); 3yr Support Req
SLES-2S2V-D1S	SUSE Linux Enterprise Svr (1-2 CPU,1-2 VM); Prio 1-Yr SnS
SLES-2S2V-D3S	SUSE Linux Enterprise Svr (1-2 CPU,1-2 VM); Prio 3-Yr SnS
SLES-2S2V-D5S	SUSE Linux Enterprise Svr (1-2 CPU,1-2 VM); Prio 5-Yr SnS
SLES-2SUVM-D1S	SUSE Linux Enterprise Svr (1-2 CPU,Unl VM) LP; Prio 1Y SnS
SLES-2SUVM-D3S	SUSE Linux Enterprise Svr (1-2 CPU,Unl VM) LP; Prio 3Y SnS
SLES-2SUVM-D5S	SUSE Linux Enterprise Svr (1-2 CPU,Unl VM) LP; Prio 5Y SnS
SLES-2S-HA-D1S	SUSE Linux High Availability Ext (1-2 CPU); 1yr SnS
SLES-2S-HA-D3S	SUSE Linux High Availability Ext (1-2 CPU); 3yr SnS
SLES-2S-HA-D5S	SUSE Linux High Availability Ext (1-2 CPU); 5yr SnS
SLES-2S-GC-D1S	SUSE Linux GEO Clustering for HA (1-2 CPU); 1yr Sns
SLES-2S-GC-D3S	SUSE Linux GEO Clustering for HA (1-2 CPU); 3yr SnS
SLES-2S-GC-D5S	SUSE Linux GEO Clustering for HA (1-2 CPU); 5yr SnS
SLES-2S-LP-D1S	SUSE Linux Live Patching Add-on (1-2 CPU); 1yr SnS Required
SLES-2S-LP-D3S	SUSE Linux Live Patching Add-on (1-2 CPU); 3yr SnS Required
SLES and SAP	
SLES-SAP-2S2V-D1S	SLES for SAP Apps (1-2 CPU, 1-2 VM); Priority 1-Yr SnS
SLES-SAP-2S2V-D3S	SLES for SAP Apps (1-2 CPU, 1-2 VM); Priority 3-Yr SnS
SLES-SAP-2S2V-D5S	SLES for SAP Apps (1-2 CPU, 1-2 VM); Priority 5-Yr SnS
SLES-SAP-2S2V-D1A	SLES for SAP Apps w/ HA (1-2 CPU, 1-2 VM); 1-Yr Support Reqd
SLES-SAP-2S2V-D3A	SLES for SAP Apps w/ HA (1-2 CPU, 1-2 VM); 3-Yr Support Reqd
SLES-SAP-2S2V-D5A	SLES for SAP Apps w/ HA (1-2 CPU, 1-2 VM); 5-Yr Support Reqd

STEP 17 CHOOSE OPTIONAL OPERATING SYSTEM MEDIA KIT

Select the optional operating system media listed in [Table 19](#).

Table 19 OS Media

Product ID (PID)	PID Description
MSWS-19-ST16CD-RM	Windows Server 2019 Stan (16 Cores/2 VMs) Rec Media DVD Only
MSWS-19-DC16CD-RM	Windows Server 2019 DC (16Cores/Unlim VM) Rec Media DVD Only
MSWS-22-ST16CD-RM	Windows Server 2022 Stan (16 Cores/2 VMs) Rec Media DVD Only
MSWS-22-DC16CD-RM	Windows Server 2022 DC (16Cores/Unlim VM) Rec Media DVD Only

SUPPLEMENTAL MATERIAL

Block Diagram

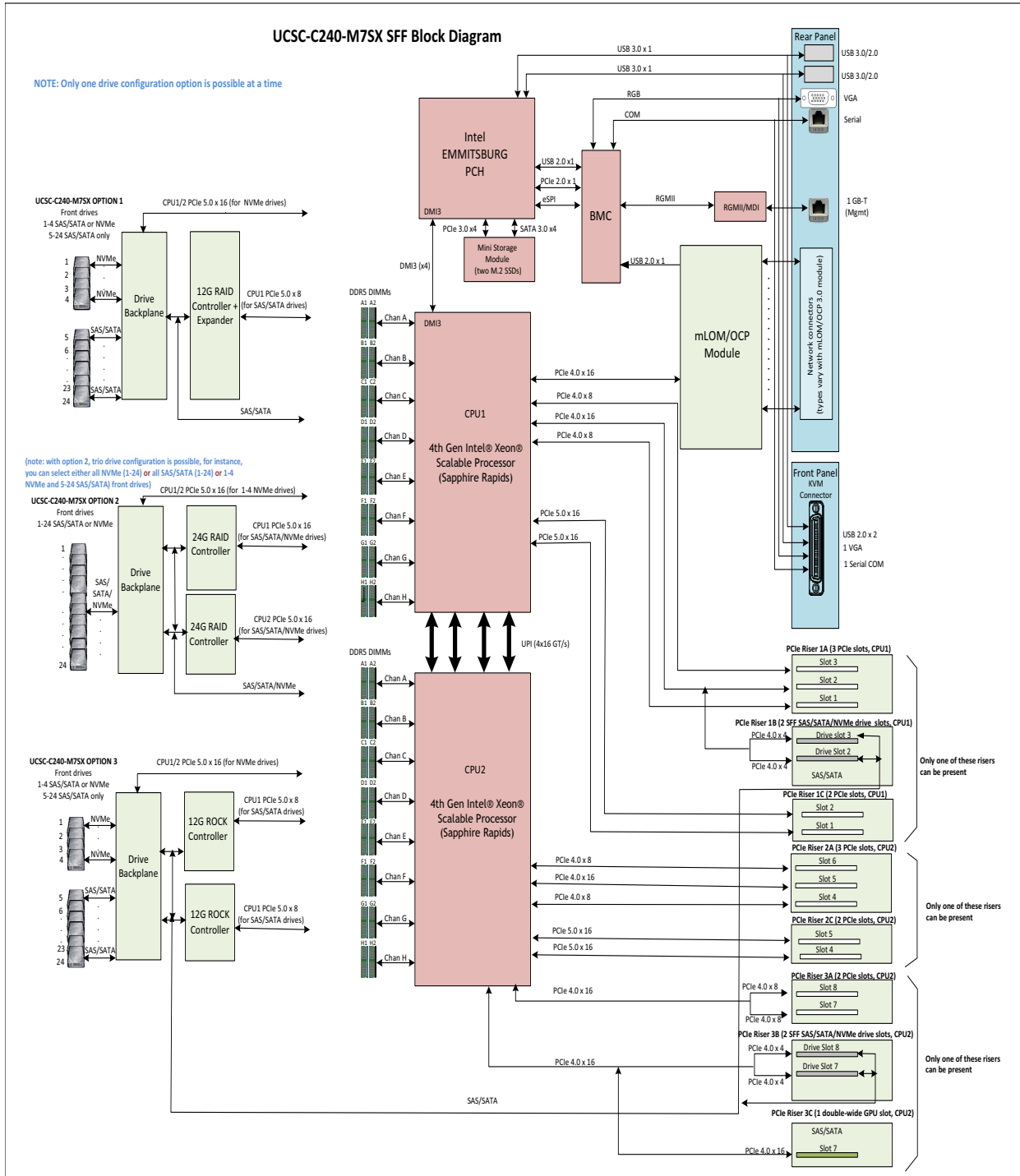

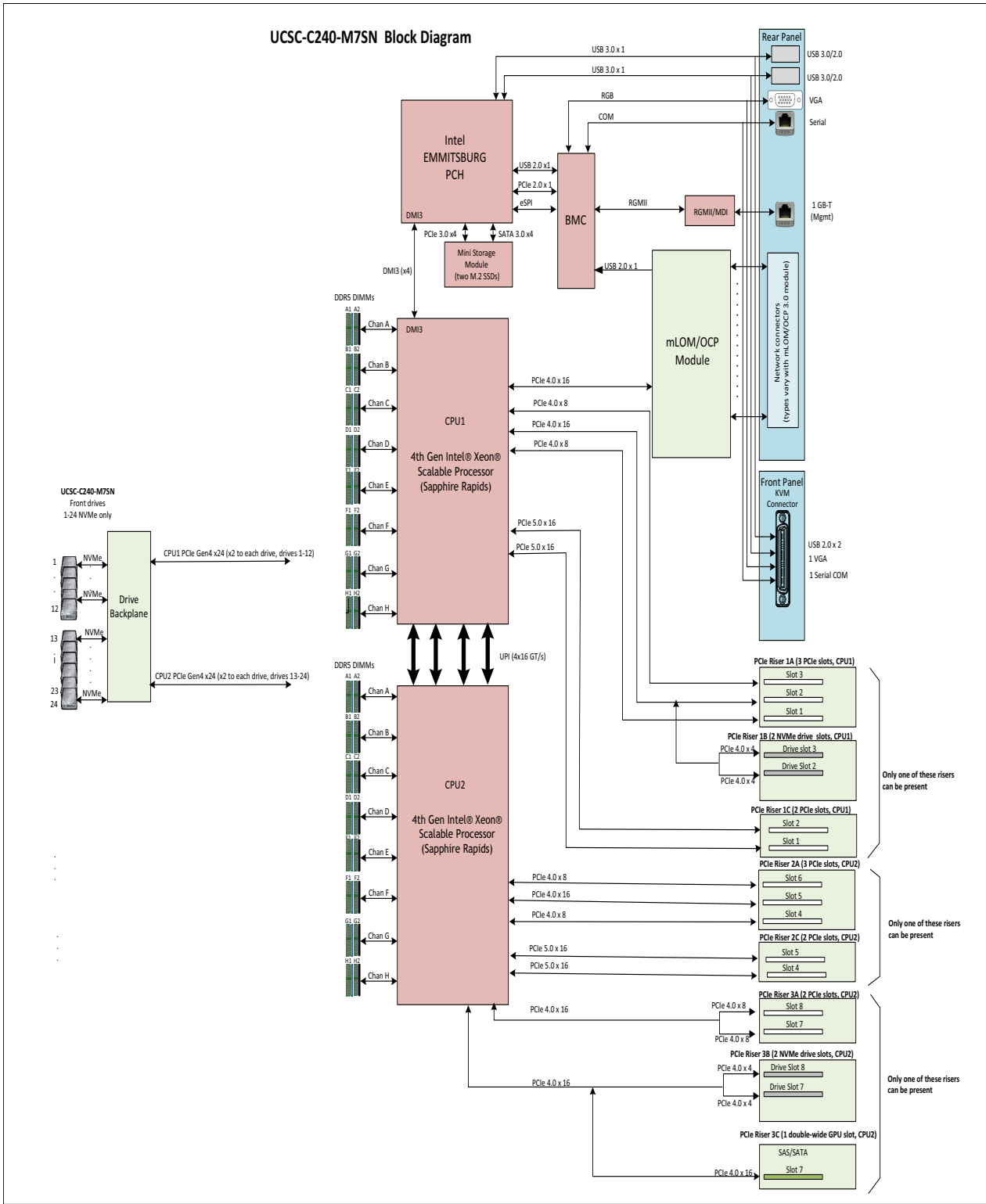

Chassis

An internal view of the C240 M7 chassis with the top cover removed is shown in [Figure 3](#).

Figure 3 C240 M7 Server With Top Cover Off

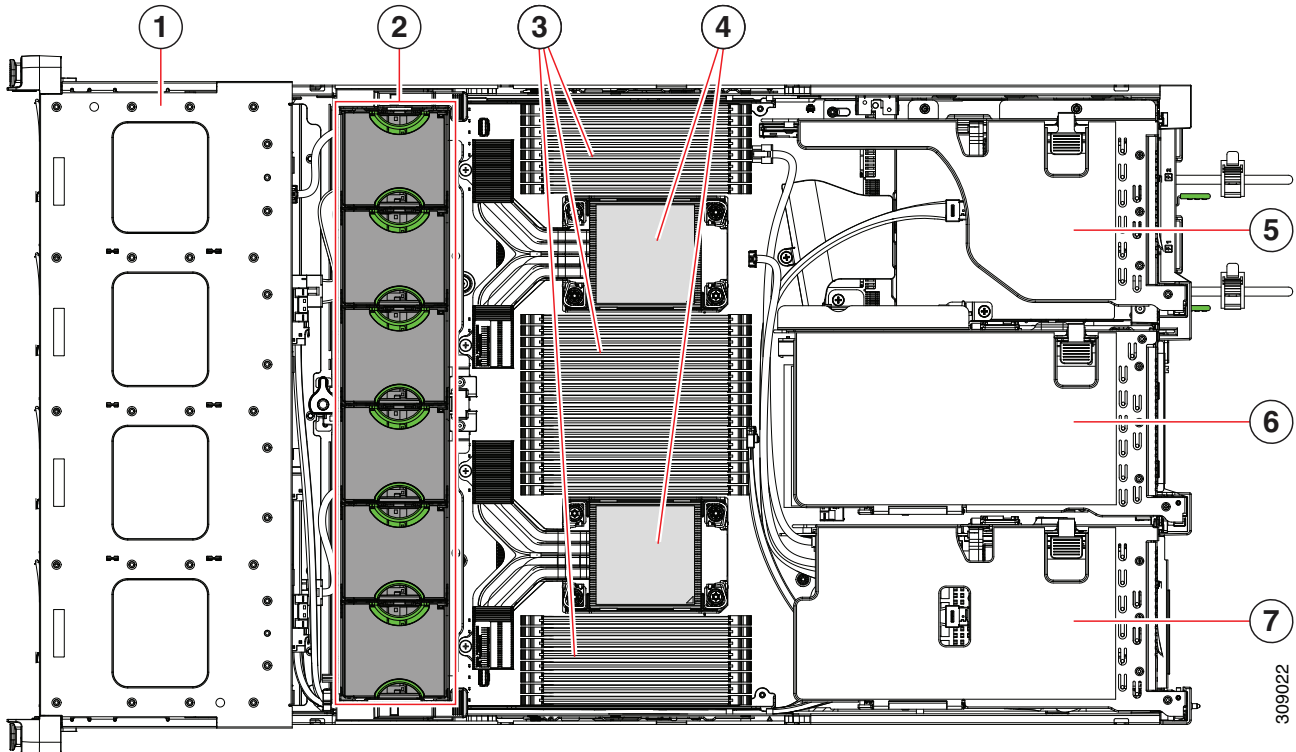

309022

1	Front-loading drive bays.	2	Cooling fan modules (six, hot-swappable)
3	DIMM socket on motherboard (16 per CPU) An air baffle rests on top of the DIMMs and CPUs when the server is operating. The air baffle is not displayed in this illustration.	4	CPU sockets CPU 2 is at the top and CPU 1 is at the bottom.

<p>5</p>	<p>PCIe riser 3 (PCIe slots 7 and 8 numbered from bottom to top), with the following options:</p> <ul style="list-style-type: none"> ■ 3A (I/O Option): <p>Slot 7 (x24 mechanical, x8 electrical) supports full height, full length GPU card</p> <p>Slot 8 (x24 mechanical, x8 electrical) supports full height, full length GPU card</p> <ul style="list-style-type: none"> ■ 3B (Storage Option): <p>Drive bay 103 (x4 electrical) supports 2.5-inch SFF universal HDD</p> <p>Drive bay 104 (x4 electrical) supports 2.5-inch SFF universal HDD</p> <ul style="list-style-type: none"> ■ 3C (GPU Option): <p>Slot 7 (x24 mechanical, x16 electrical) support a full height, full length, double-wide GPU card</p> <p>Slot 8 empty (No NCSI support)</p>	<p>6</p>	<p>PCIe riser 2 (PCIe slots 4, 5, 6 numbered from bottom to top), with the following options:</p> <ul style="list-style-type: none"> ■ 2A (I/O Option): <p>Slot 4 (x24 mechanical, x8 electrical) supports full height, ¾ length card;</p> <p>Slot 5 (x24 mechanical, x16 electrical) supports full height, full length GPU card;</p> <p>Slot 6 (x16 mechanical, x8 electrical) supports full height, full length card</p> <ul style="list-style-type: none"> ■ 2C (I/O Option): <p>Slot 4 (x24 mechanical, x16 electrical) supports full height, ¾ length card;</p> <p>Slot 5 (x16 mechanical, x16 electrical) supports full height, full length GPU card</p>
<p>7</p>	<p>PCIe riser 1 (PCIe slot 1, 2, 3 numbered bottom to top), with the following options:</p> <ul style="list-style-type: none"> ■ 1A (I/O Option): <p>Slot 1 (x24 mechanical, x8 electrical) supports full height, ¾ length card;</p> <p>Slot 2 (x24 mechanical, x16 electrical) supports full height, full length GPU card;</p> <p>Slot 3 (x24 mechanical, x16 electrical) supports full height, full length card.</p> <ul style="list-style-type: none"> ■ 1B (Storage Option): <p>Slot 1 is reserved;</p> <p>Drive bay 101 (x4 electrical), supports 2.5-inch SFF universal HDD;</p> <p>Drive bay 102 (x4 electrical), supports 2.5-inch SFF universal HDD</p> <ul style="list-style-type: none"> ■ 1C (I/O Option): <p>Slot 1 (x24 mechanical, x16 electrical) supports full height, ¾ length card;</p> <p>Slot 2 (x16 mechanical, x16 electrical) supports full height, full length GPU card.</p>	<p>-</p>	

Risers

Figure 4 shows the locations of the PCIe riser connectors on Cisco UCS C240 M7 SFF motherboard.

Figure 4 C240 M7 SFF Riser Connector Locations

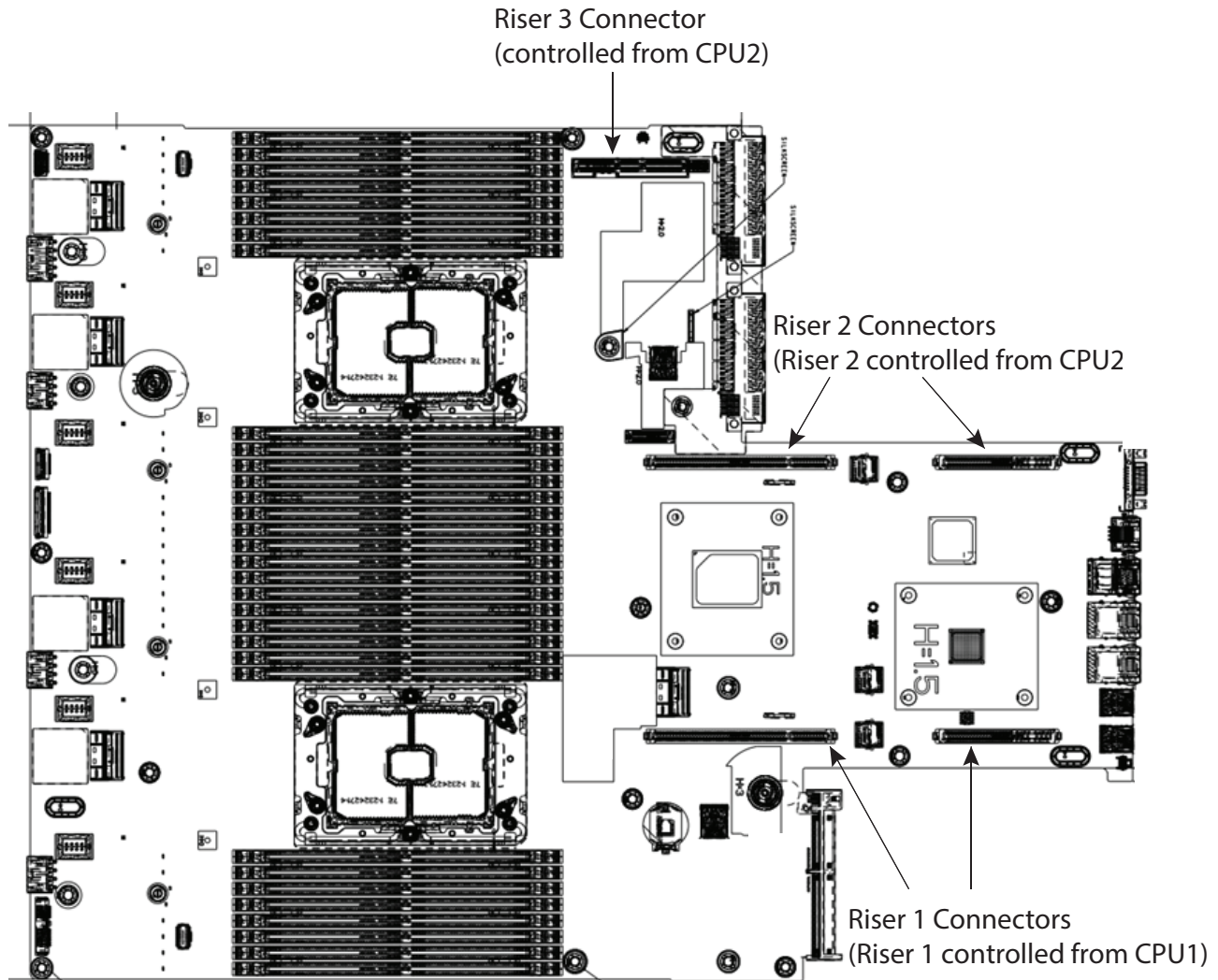
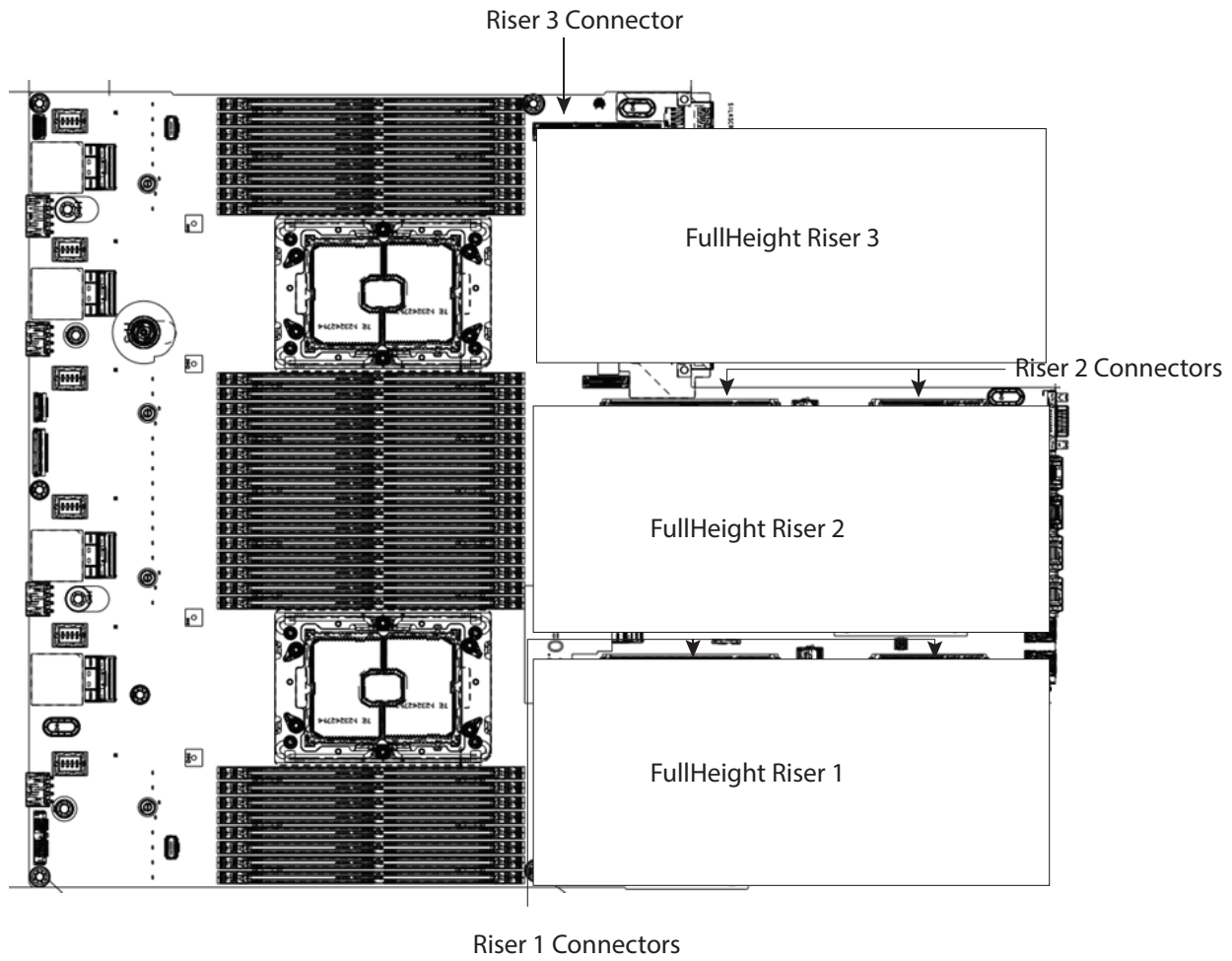

Figure 5 shows the locations of the PCIe riser connectors on Cisco UCS C240 M7 SFF motherboard.

Figure 5 C240 M7 SFF Riser Connector Locations



Riser Card Configurations and Options

The riser card locations are shown in [Figure 6](#).

Figure 6 Riser Card Locations

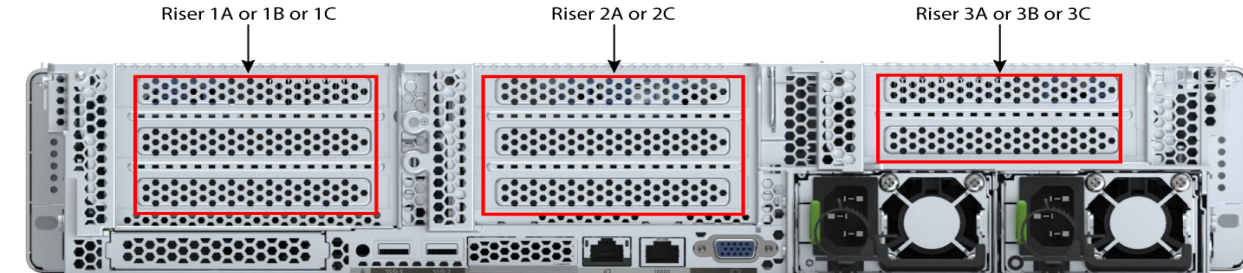

Riser 1A

Riser 1A mechanical information is shown in [Figure 7](#).

Figure 7 Riser Card 1A

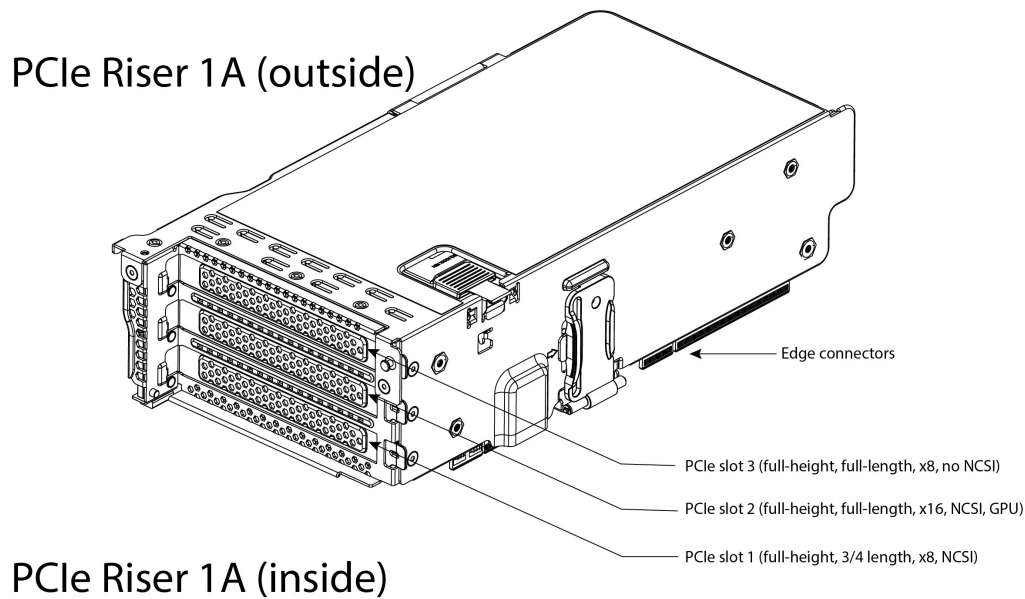

Riser 1B

Riser 1B mechanical information is shown in [Figure 8](#).

Figure 8 Riser Card 1B

PCIe Riser 1B (outside)

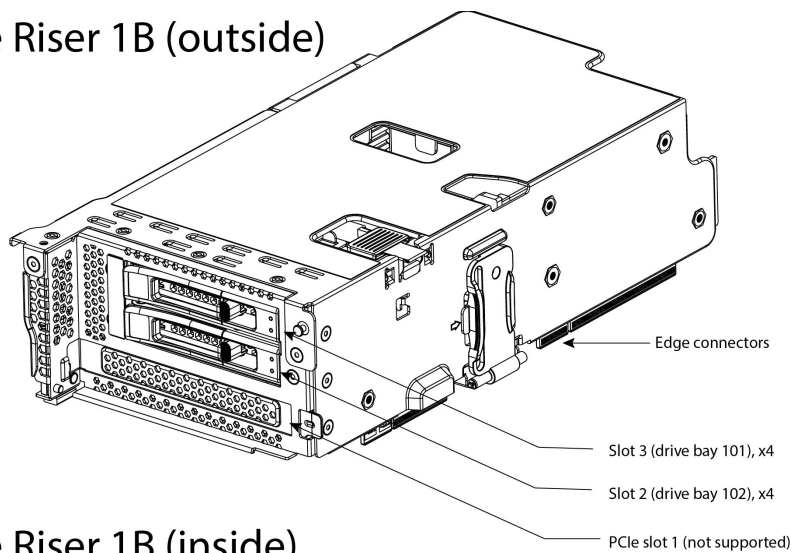

PCIe Riser 1B (inside)

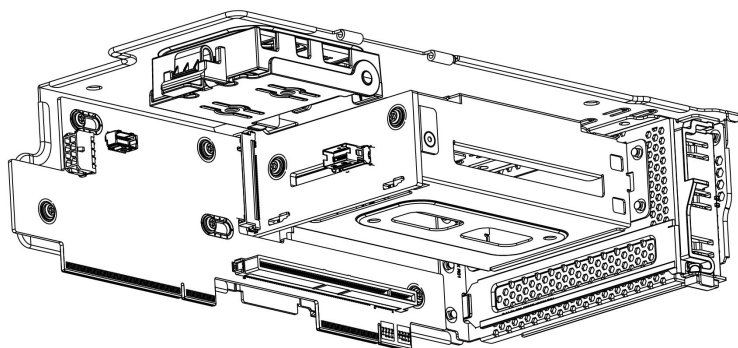

Riser 1C

Riser 1C mechanical information is shown in [Figure 9](#).

Figure 9 Riser Card 1C

PCIe Riser 1C (outside)

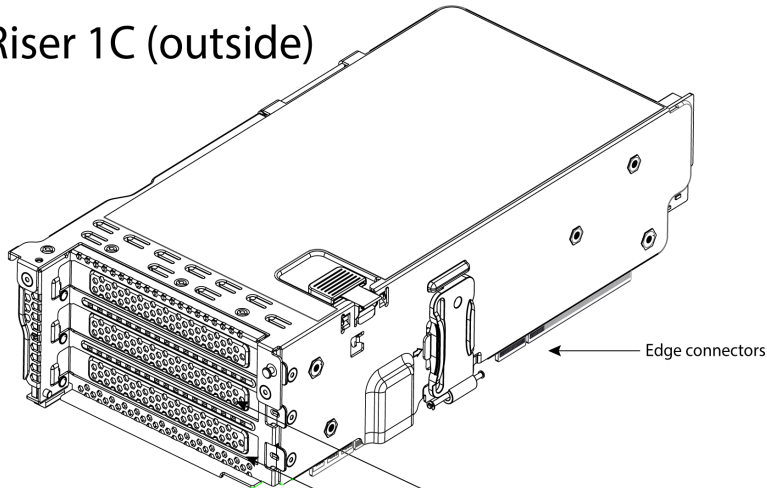

PCIe Riser 1C (inside)

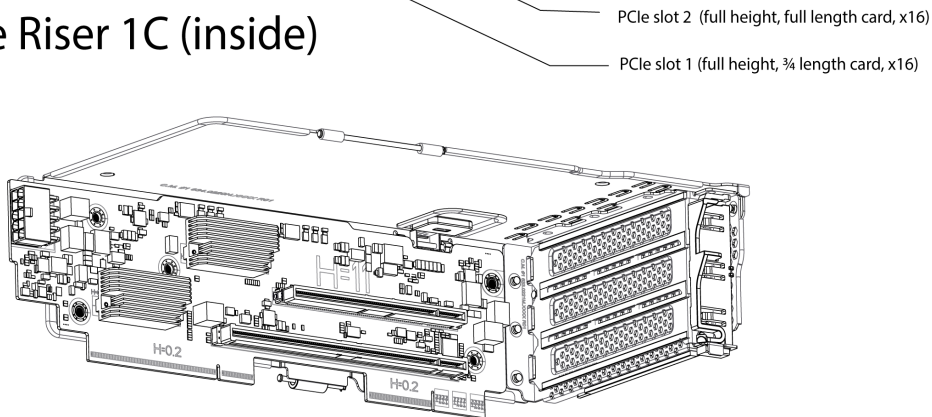

Riser 2A

Riser 2A mechanical information is shown in [Figure 10](#).

Figure 10 Riser Card 2A

PCIe Riser 2A (outside)

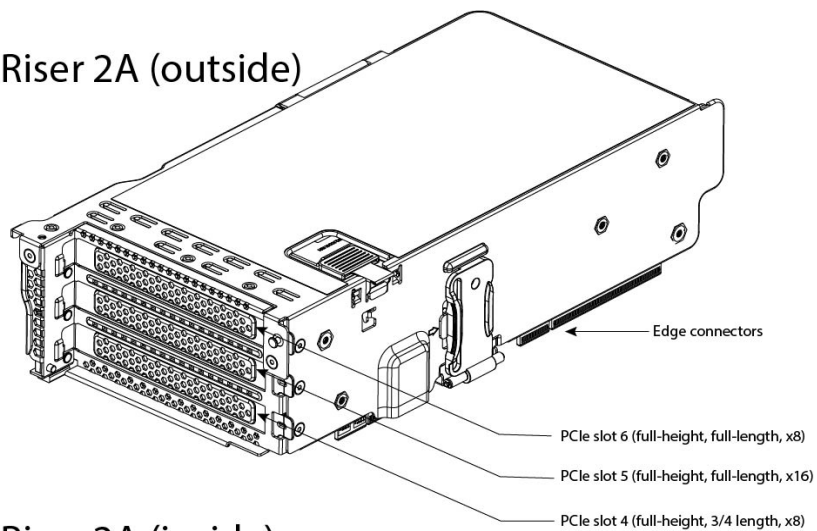

PCIe Riser 2A (inside)

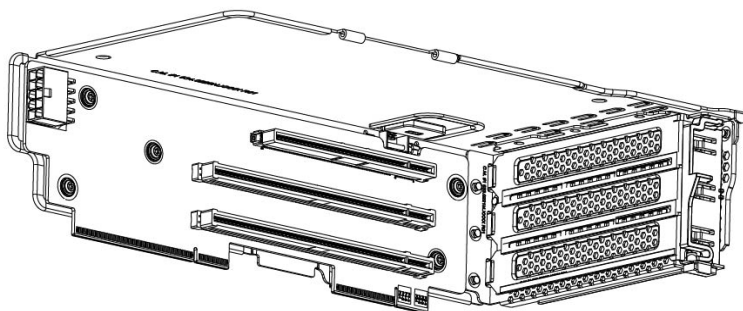

Riser 2C

Riser 2C mechanical information is shown in [Figure 11](#).

Figure 11 Riser Card 2C

PCIe Riser 2C (outside)

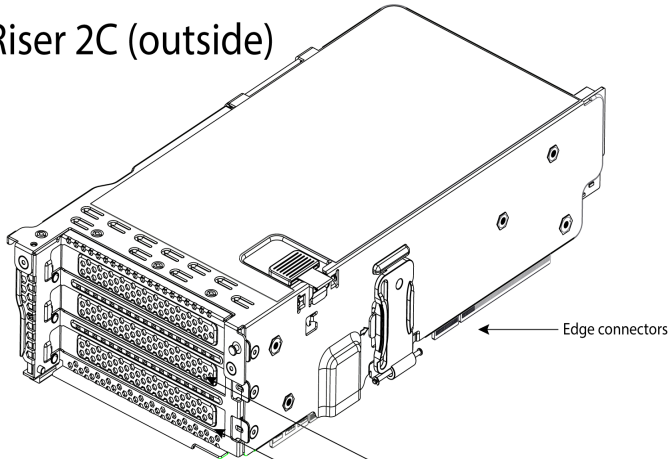

PCIe Riser 2C (inside)

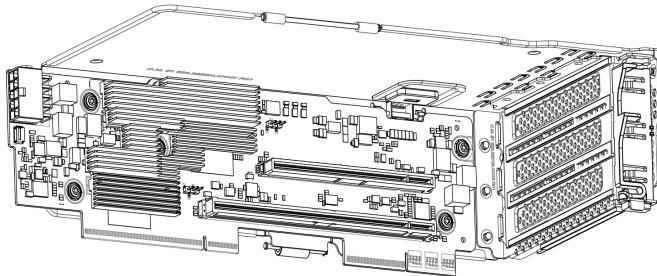

Riser 3A

Riser 3A mechanical information is shown in [Figure 12](#).

Figure 12 Riser Card 3A

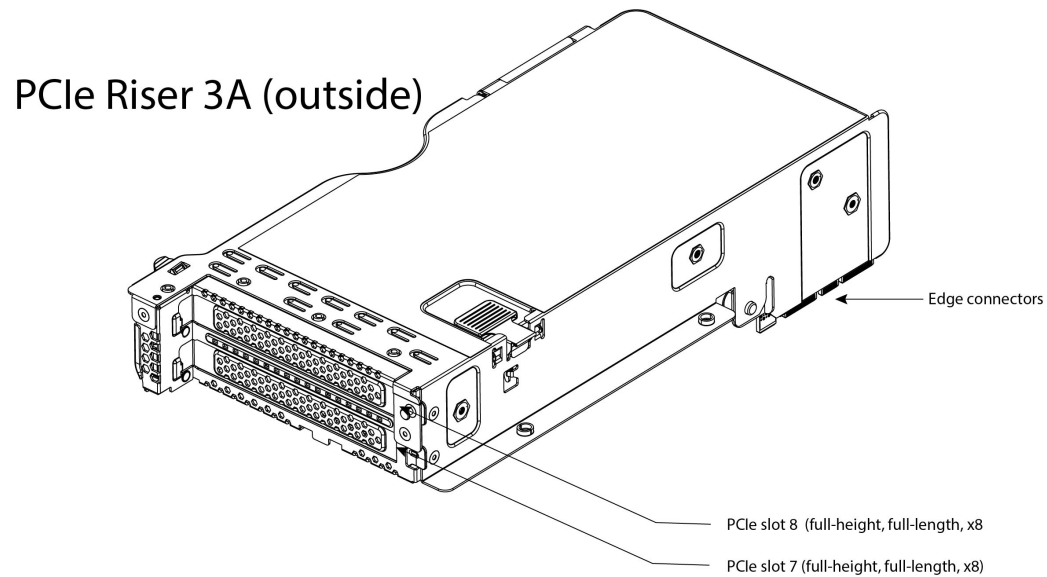

PCIe Riser 3A (inside)

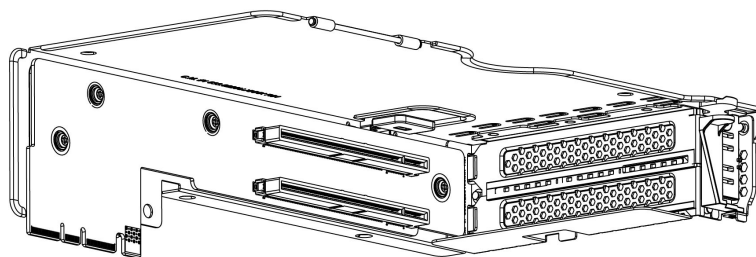

Riser 3B

Riser 3B mechanical information is shown in [Figure 13](#).

Figure 13 Riser Card 3B

PCIe Riser 3B (outside)

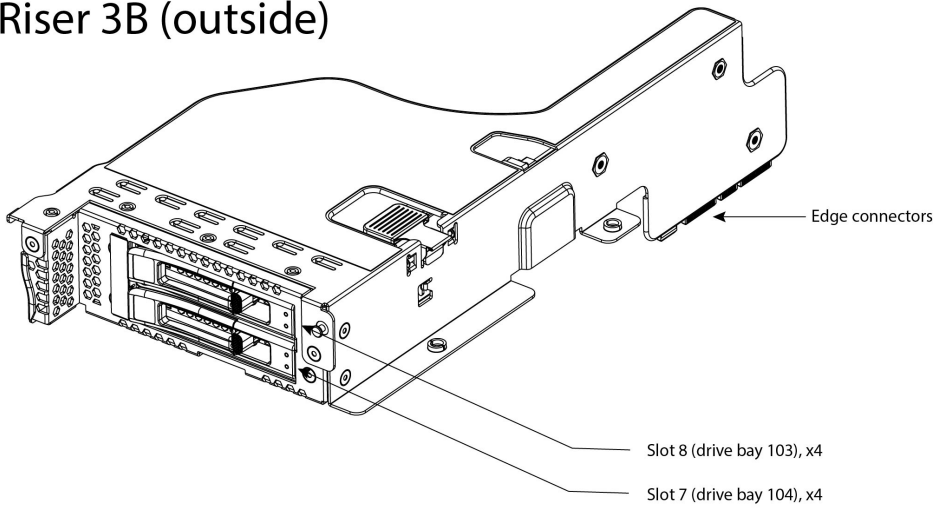

PCIe Riser 3B (inside)

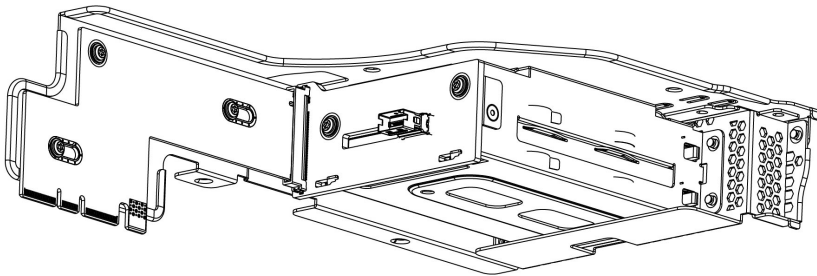

Riser 3C

Riser 3C mechanical information is shown in [Figure 14](#).

Figure 14 Riser Card 3C

PCIe Riser 3C (outside)

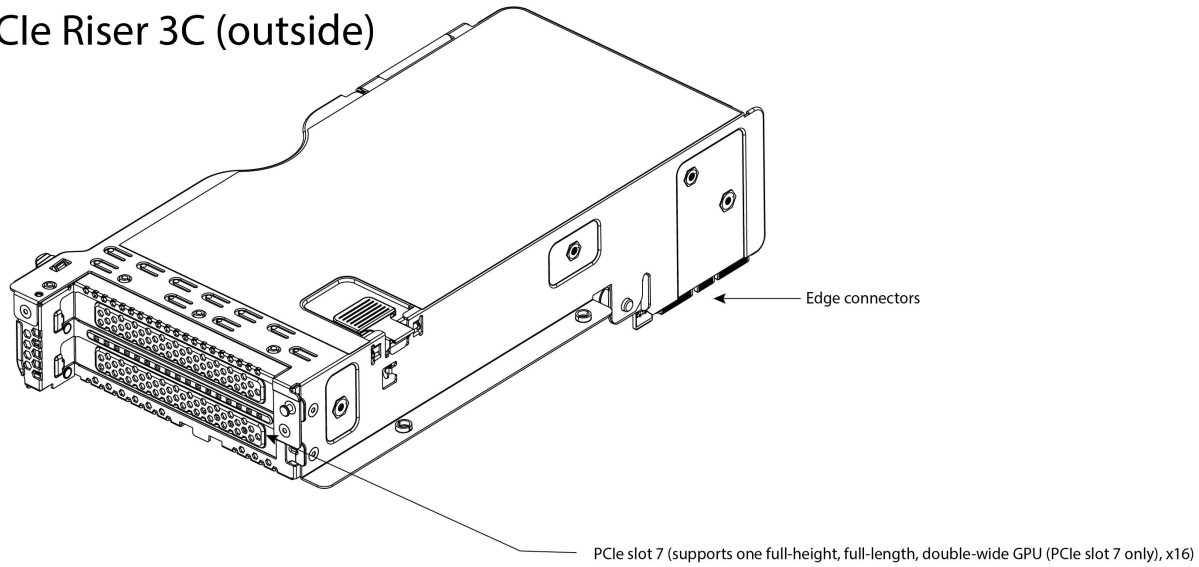

PCIe Riser 3C (inside)

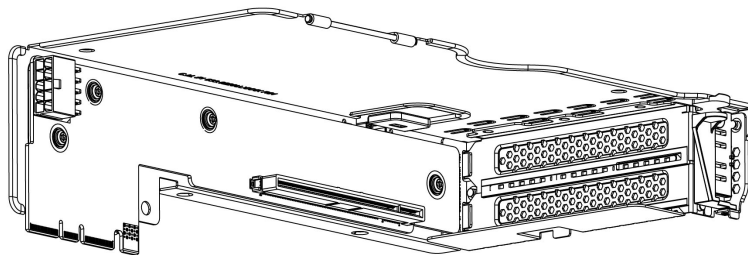

Serial Port Details

The pinout details of the rear RJ-45 serial port connector are shown in [Figure 15](#).

Figure 15 Serial Port (Female RJ-45 Connector) Pinout
Serial Port (RJ-45 Female Connector)

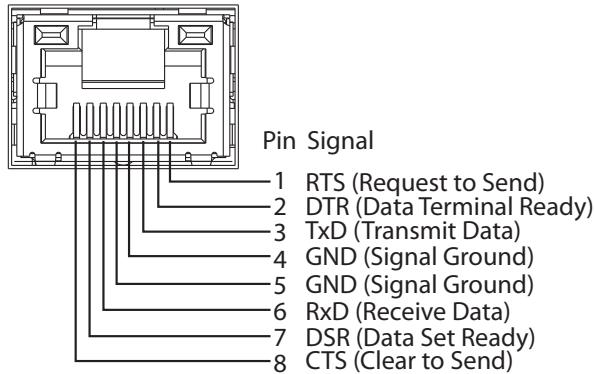

KVM Cable

The KVM cable provides a connection into the server, providing a DB9 serial connector, a VGA connector for a monitor, and dual USB 2.0 ports for a keyboard and mouse. With this cable, you can create a direct connection to the operating system and the BIOS running on the server.

The KVM cable ordering information is listed in [Table 20](#).

Table 20 KVM Cable

Product ID (PID)	PID Description
N20-BKVM-D	KVM cable for server console port

Figure 16 KVM Cable

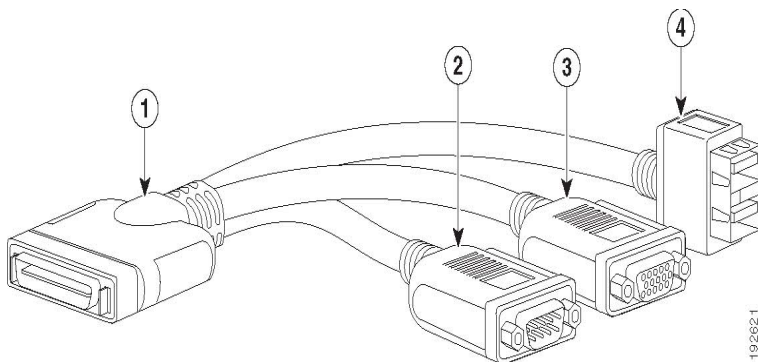

1	Connector (to server front panel)	3	VGA connector (for a monitor)
2	DB-9 serial connector	4	Two-port USB 2.0 connector (for a mouse and keyboard)

UPGRADING or REPLACING CPUs and Memory

- Refer to [Cisco UCS C240 M7 Server Installation and Service Guide](#) to upgrading or replacing the CPUs
- Refer to [Cisco UCS C240 M7 Server Installation and Service Guide](#) to upgrading or replacing the Memory

SPARE PARTS

This section lists the upgrade and service-related parts for the UCS C240 M7 server. Some of these parts are configured with every server.



NOTE: Some spare parts you order may also require accessories for full functionality. For example, drives or RAID controllers may need accompanying cables. CPUs may need heatsinks, thermal paste, and installation tools. The spares and their accessory parts are listed in [Table 21](#).

Table 21 Spare Parts

Product ID (PID)	Description
Risers	
<p>Note: Please note, if you are adding additional risers and raid controller later, you may need to order the accessories with it.</p>	
Option 1	
UCSC-RIS1A-240-D=	C240 M7 Riser 1A PCIe Gen4 (controlled with CPU1)
UCSC-RIS1B-24XM7=	C240 M7 Riser 1B (controlled with CPU1)
UCSC-RIS1C-24XM7=	C240 M7 Riser 1C PCIe Gen 5 (controlled with CPU1)
Option 2 (2-CPU must be selected)	
UCSC-RIS2A-240-D=	C240 M7 Riser 2A PCIe Gen4 (controlled with CPU2)
UCSC-RIS2C-24XM7=	C240 M7 Riser 2C PCIe Gen5 (controlled with CPU2)
Option 3 (2-CPU must be selected)	
UCSC-RIS3A-240-D=	C240 M7 Riser 3A PCIe Gen4 (controlled with CPU2)
UCSC-RIS3B-24XM7=	C240 M7 Riser 3B (controlled with CPU2)
UCSC-RIS3C-240-D=	C240 M7 Riser 3C (controlled with CPU2)
Riser accessories	
UCSC-FBRS2-C240-D=	C240 M7 2U Riser2 Filler Blank
UCSC-FBRS3-C240-D=	C240 M7 2U Riser3 Filler Blank
CBL-SASR1B-C24XM7=	UCS C-Series M7 2U SAS Cable, RISER1B TO RB 2
<p>Note: This cable may be required, if you order riser PID UCSC-RIS1B-240M6 and UCSC-RAID-HP for UCSC-C240-M7SX</p>	

Table 21 Spare Parts





Product ID (PID)	Description
CBL-RSASR1B-240-D=  Note: This cable may required, if you order riser PID UCSC-RIS1B-240M6 and UCSC-SAS-T-D for UCSC-C240-M7SX	C240M7 2U x2 Rear SAS/SATA cable; (Riser1B)
CBL-SASR3B-C24XM7=  Note: This cable may required, if you order riser PID UCSC-RIS1B-240M6 and UCSC-RAID-HP for UCSC-C240-M7SX	UCS C-Series M7 2U SAS Cable, RISER3B TO RB 1
CBL-RSASR3B-240-D=  Note: This cable may required, if you order riser PID UCSC-RIS1B-240M6 and UCSC-SAS-T-D or UCSC-RAID-SD-D for UCSC-C240-M7SX	C240M7 2U x2 Rear SAS/SATA cable; (Riser3B)
UCSC-RISAB-24XM7=  Note: : For systems with GPU configured, airblockers are required on risers. Please refer to the install guide for details.	UCS C-Series M7 2U Air Blocker GPU only
CPUs  Note: If you are ordering a second CPU, see the CPU Accessories section in this table for additional parts you may need to order for the second CPU.	
8000 Series Processors	
UCS-CPU-I8490H=	
UCS-CPU-I8480+=	
UCS-CPU-I8471N=	
UCS-CPU-I8470N=	

Table 21 Spare Parts

Product ID (PID)	Description
UCS-CPU-I8470=	
UCS-CPU-I8468V=	
UCS-CPU-I8468H=	
UCS-CPU-I8468=	
UCS-CPU-I8462Y+=	
UCS-CPU-I8461V=	
UCS-CPU-I8460Y+=	
UCS-CPU-I8460H=	
UCS-CPU-I8458P=	
UCS-CPU-I8454H=	
UCS-CPU-I8452Y=	
UCS-CPU-I8450H=	
UCS-CPU-I8444H=	
6000 Series Processors	
UCS-CPU-I6454S=	
UCS-CPU-I6448Y=	
UCS-CPU-I6448H=	
UCS-CPU-I6444Y=	
UCS-CPU-I6442Y=	
UCS-CPU-I6438Y+=	
UCS-CPU-I6438N=	
UCS-CPU-I6438M=	
UCS-CPU-I6434H=	
UCS-CPU-I6434=	
UCS-CPU-I6430=	
UCS-CPU-I6428N=	
UCS-CPU-I6426Y=	
UCS-CPU-I6421N=	
UCS-CPU-I6418H=	
UCS-CPU-I6416H=	
UCS-CPU-I6414U=	
5000 Series Processors	

Table 21 Spare Parts





Product ID (PID)	Description
UCS-CPU-I5420+=	
UCS-CPU-I5418Y=	
UCS-CPU-I5418N=	
UCS-CPU-I5416S=	
UCS-CPU-I5415+=	
UCS-CPU-I5412U=	
UCS-CPU-I5411N=	
4000 Series Processors	
UCS-CPU-I4416+=	
UCS-CPU-I4410Y=	
UCS-CPU-I4410T=	
3000 Series Processors	
UCS-CPU-I3408U=	
CPU Accessories	
UCSC-HSHP-C240M7=  Note: if you are adding a second CPU later, you will need to order this heat sink	UCS C240 M7 Heatsink
UCS-CPU-TIM=  Note: This part is included with the purchase of spare CPU.Can be ordered separately.	Single CPU thermal interface material syringe for M5 server HS seal ¹
UCS-M6-CPU-CAR=  Note: This part is included with the purchase of spare CPU.Can be ordered separately.	Spare CPU Carrier for M6
UCSX-HSCK=  Note: This part is included with the purchase of spare CPU.Can be ordered separately.	UCS CPU/Heatsink Cleaning Kit, for up to 4 CPU/heatsink sets

Table 21 Spare Parts



Product ID (PID)	Description
UCS-CPUAT=  Note: This part is included with the purchase of spare CPU.Can be ordered separately.	CPU Assembly Tool for Servers
Memory	
UCS-MRX16G1RE1=	16GB DDR5-4800 RDIMM 1Rx8 (16Gb)
UCS-MRX32G1RE1=	32GB DDR5-4800 RDIMM 1Rx4 (16Gb)
UCS-MRX64G2RE1=	64GB DDR5-4800 RDIMM 2Rx4 (16Gb)
UCS-MR128G4RE1=	128GB DDR5-4800 RDIMM 4Rx4 (16Gb)
UCS-MR256G8RE1=	256GB DDR5-4800 RDIMM 8Rx4 (16Gb)
UCS-DDR5-BLK=  Note: Order this DIMM Blank, if you are not using DIMM slots. Any empty DIMM slot must be populated with a DIMM blank to maintain proper cooling airflow.	UCS DDR5 DIMM Blanks
RAID Controllers  Note: When ordering additional RAID controllers, you may need to order a cable/supercap to connect from the RAID controller to the motherboard. See the RAID Controller Accessories section in this table.	
UCSC-RAID-HP=	Cisco Tri-Mode 24G SAS RAID Controller w/4GB Cache
UCSC-RAID-HP= accessories (note: the below accessories only required if it is not in the system configuration. Must select all option within a single accessory or OPTOUT PID.	
UCS-SCAP-D=	M7 SuperCap
CBL-SCAP-C240-D=	C240M7 2U Super Cap cable
CBL-SAS-Y-C240M7=	C240M7 SAS Y CABLE; MB to 24G SAS RAID Controller, X2
UCSC-HPBKT-24XM7=	UCS C-Series M7 2U HP RAID Controller Bracket
UCSC-OPTOUT=	Opt out from Ordering Accessories
UCSC-RAID-SD-D=	Cisco 12G SAS RAID Controller with 4GB FBWC (28 Drives)
UCSC-RAID-SD-D= accessories (note: the below accessories only required if it is not in the system configuration. Must select all option within a single accessory or OPTOUT PID.	
UCS-SCAP-D=	M7 SuperCap
CBL-SCAP-C240-D=	C240M7 2U Super Cap cable
CBL-SDSAS-C240M7=	C240M7 SAS Cable, CPU1 P-1 TO SAS RAID Controller
UCSC-SDBKT-24XM7=	UCS C-Series M7 2U SD RAID Controller Bracket
UCSC-OPTOUT=	Opt out from Ordering Accessories

Table 21 Spare Parts

Product ID (PID)	Description
UCSC-SAS-T-D=	Cisco M6 12G SAS HBA for (16 Drives)
UCSC-SAS-T-D= accessories (note: the below accessories only required if it is not in the system configuration. Must select all option within a single accessory or OPTOUT PID.	
UCSC-RDBKT-24XM7=	UCS C-Series M7 2U RAID/HBA Controller Bracket
CBL-SAS12-C240M7=	C240M7SX, Cable MB CPU1 P-2 to PB/PR1
CBL-SAS24-C240M7=	C240M7SX, Cable MB CPU1 P-1 to PB/PR2 & HDD 1-2
UCSC-OPTOUT=	Opt out from Ordering Accessories
Controller for External Drives	
UCSC-9500-8E-D=	9500 Series PCIe Gen 4.0 Tri-Mode Storage HBA 12Gb/s SAS/SATA/PCIe (NVMe)
Drives	
 <p>Note: If you decide to add front-facing NVMe drives later, you may need to order the drives as spare and also an NVMe cable (PID: CBL-NVME-C240M7= or CBL-FNVME-C240M7=). Spare NVMe cables supports depends on the drive controller installing/installed in the system. See the Drive Cables section in this table.</p>	
PCIe/NVMe SFF (2.5-inch) SFF drives	
UCS-NVMEXP-I400-D=	400GB 2.5in U.2 Intel P5800X Optane NVMe Extreme Perform SSD
UCS-NVMEXP-I800-D=	800GB 2.5in U.2 Intel P5800X Optane NVMe Extreme Perform SSD
UCS-NVME4-1600-D=	1.6TB 2.5in U.2 P5620 NVMe High Perf High Endurance
UCS-NVME4-1920-D=	1.9TB 2.5in U.2 P5520 NVMe High Perf Medium Endurance
UCS-NVME4-3200-D=	3.2TB 2.5in U.2 P5620 NVMe High Perf High Endurance
UCS-NVME4-3840-D=	3.8TB 2.5in U.2 P5520 NVMe High Perf Medium Endurance
UCS-NVME4-6400-D=	6.4TB 2.5in U.2 P5620 NVMe High Perf High Endurance
UCS-NVME4-7680-D=	7.6TB 2.5in U.2 P5520 NVMe High Perf Medium Endurance
UCS-NVME4-15360-D=	15.3TB 2.5in U.2 P5520 NVMe High Perf Medium Endurance
UCS-NVMEQ-1536-D=	15.3TB 2.5in U.2 P5316 NVMe High Perf Low Endurance
UCS-NVMEG4-M960-D=	960GB 2.5in U.3 Micron P7450 NVMe High Perf Medium Endurance
UCS-NVMEG4-M1920D=	1.9TB 2.5in U.3 Micron P7450 NVMe High Perf Medium Endurance
UCS-NVMEG4-M3840D=	3.8TB 2.5in U.3 Micron P7450 NVMe High Perf Medium Endurance
UCS-NVMEG4-M7680D=	7.6TB 2.5in U.3 Micron P7450 NVMe High Perf Medium Endurance
UCS-NVMEG4-M1536D=	15.3TB 2.5in U.3 Micron P7450 NVMe High Perf Medium Endurance
UCS-NVMEG4-M1600D=	1.6TB 2.5in U.3 Micron P7450 NVMe High Perf High Endurance
UCS-NVMEG4-M3200D=	3.2TB 2.5in U.3 Micron P7450 NVMe High Perf High Endurance
UCS-NVMEG4-M6400D=	6.4TB 2.5in U.3 Micron P7450 NVMe High Perf High Endurance
HDDs	
HDDs (10K RPM)	
UCS-HD600G10KJ4-D=	600 GB 12G SAS 10K RPM SFF HDD
UCS-HD12TB10KJ4-D=	1.2 TB 12G SAS 10K RPM SFF HDD
UCS-HD18TB10KJ4-D=	1.8 TB 12G SAS 10K RPM SFF HDD (4K)
UCS-HD24TB10KJ4-D=	2.4 TB 12G SAS 10K RPM SFF HDD (4K)

Table 21 Spare Parts

Product ID (PID)	Description
Enterprise Performance SAS/SATA SSDs (High endurance, supports up to 10X or 3X DWPD (drive writes per day))	
SATA	
UCS-SD480G63XEP-D=	480 GB 2.5in Enterprise Performance 6G SATA SSD(3X endurance)
UCS-SD480GM3XEP-D=	480 GB 2.5in Enterprise Performance 6G SATA SSD(3X endurance)
UCS-SD960G63XEP-D=	960 GB 2.5in Enterprise performance 6G SATA SSD(3X endurance)
UCS-SD960GM3XEP-D=	960 GB 2.5in Enterprise performance 6G SATA SSD(3X endurance)
UCS-SD19T63X-EP-D=	1.9 TB 2.5in Enterprise performance 6G SATA SSD(3X endurance)
UCS-SD19TM3X-EP-D=	1.9 TB 2.5in Enterprise performance 6G SATA SSD(3X endurance)
UCS-SD38T63X-EP-D=	3.8 TB 2.5in Enterprise performance 6G SATA SSD(3X endurance)
UCS-SD480GBM3XEPD=	480GB SATA SSD 3DWPD
UCS-SD960GBM3XEPD=	960GB SATA SSD 3DWPD
UCS-SD19TBM3XEP-D=	1.9TB SATA SSD 3DWPD
SAS	
UCS-SD800GK3XEP-D=	800 GB 2.5in Enterprise Performance 12G SAS SSD(3X endurance)
UCS-SD800GS3XEP-D=	800 GB 2.5in Enterprise Performance 12G SAS SSD(3X endurance)
UCS-SD16TK3X-EP-D=	1.6 TB 2.5in Enterprise Performance 12G SAS SSD(3X endurance)
UCS-SD16TS3X-EP-D=	1.6 TB 2.5in Enterprise Performance 12G SAS SSD(3X endurance)
UCS-SD32TK3X-EP-D=	3.2 TB 2.5in Enterprise Performance 12G SAS SSD(3X endurance)
UCS-SD32TS3X-EP-D=	3.2 TB 2.5in Enterprise Performance 12G SAS SSD(3X endurance)
UCS-SD16TKA3XEP-D=	1.6TB 2.5in Enterprise Performance 12G SAS SSD(3X endurance)
UCS-SD32TKA3XEP-D=	3.2TB 2.5in Enterprise Performance 12G SAS SSD(3X endurance)
Enterprise Value SAS/SATA SSDs (Low endurance, supports up to 1X DWPD (drive writes per day))	
SATA	
UCS-SD240GM1XEVD=	240GB 2.5 inch Enterprise Value 6G SATA SSD
UCS-SD480GM1XEVD=	480 GB 2.5 inch Enterprise Value 6G SATA SSD
UCSSD480G611XEVD=	480GB 2.5 inch Enterprise Value 6G SATA SSD
UCSSD960G6S1XEVD=	960GB 2.5 inch Enterprise Value 6G SATA SSD
UCSSD960G611XEVD=	960GB 2.5 inch Enterprise Value 6G SATA SSD
UCS-SD960GM1XEVD=	960GB 2.5 inch Enterprise Value 6G SATA SSD
UCS-SD16TM1X-EV-D=	1.6TB 2.5 inch Enterprise Value 6G SATA SSD
UCS-SD19T6S1XEVD=	1.9TB 2.5 inch Enterprise Value 6G SATA SSD
UCS-SD19TM1X-EV-D=	1.9TB 2.5 inch Enterprise Value 6G SATA SSD
UCS-SD38T6S1XEVD=	3.8 TB 2.5 inch Enterprise Value 6G SATA SSD
UCS-SD38TM1X-EV-D=	3.8 TB 2.5 inch Enterprise Value 6G SATA SSD
UCS-SD38T6I1XEVD=	3.8TB 2.5 inch Enterprise Value 6G SATA SSD
UCS-SD76T6S1XEVD=	7.6TB 2.5 inch Enterprise Value 6G SATA SSD
UCS-SD76TM1X-EV-D=	7.6TB 2.5 inch Enterprise Value 6G SATA SSD
UCS-SD240GBM1XEVD=	240GB SATA SSD 1DWPD
UCS-SD480GBM1XEVD=	480GB SATA SSD 1DWPD

Table 21 Spare Parts

Product ID (PID)	Description
UCS-SD960GBM1XEVD=	960GB SATA SSD 1DWPD
UCS-SD16TBM1XEVD=	1.6GB SATA SSD 1DWPD
UCS-SD19TBM1XEVD=	1.9TB SATA SSD 1DWPD
UCS-SD38TBM1XEVD=	3.8TB SATA SSD 1DWPD
UCS-SD76TBM1XEVD=	7.6TB SATA SSD 1DWPD
SAS	
UCS-SD960GK1XEVD=	960GB 2.5 inch Enterprise Value 12G SAS SSD
UCS-SD960GS1XEVD=	960GB 2.5 inch Enterprise Value 12G SAS SSD
UCS-SD19TK1X-EVD=	1.9TB 2.5 inch Enterprise Value 12G SAS SSD
UCS-SD19TS1X-EVD=	1.9TB 2.5 inch Enterprise Value 12G SAS SSD
UCS-SD38TK1X-EVD=	3.8TB 2.5 inch Enterprise Value 12G SAS SSD
UCS-SD38TS1X-EVD=	3.8TB 2.5 inch Enterprise Value 12G SAS SSD
UCS-SD76TK1X-EVD=	7.6TB 2.5 inch Enterprise Value 12G SAS SSD
UCS-SD15TK1X-EVD=	15.3TB 2.5 inch Enterprise Value 12G SAS SSD
UCS-SD19TKA1XEVD=	1.9TB 2.5 inch Enterprise Value 12G SAS SSD
UCS-SD38TKA1XEVD=	3.8TB 2.5 inch Enterprise Value 12G SAS SSD
UCS-SD76TKA1XEVD=	7.6TB 2.5 inch Enterprise Value 12G SAS SSD
UCS-SD15TKA1XEVD=	15.3TB 2.5 inch Enterprise Value 12G SAS SSD
Self-Encrypted Drives (SED) (1X or 3X)	
SATA	
UCSSD960GBM2NK9-D=	960GB Enterprise value SATA SSD (1X, SED) Non FIPS
UCSSD19TBEM2NK9-D=	1.9TB Enterprise value SATA SSD (1X , SED) Non FIPS
UCSSD38TBEM2NK9-D=	3.8TB Enterprise value SATA SSD (1X, SED) Non FIPS
UCSSD76TBEM2NK9-D=	7.6TB Enterprise value SATA SSD (1X, SED) Non FIPS
SAS	
UCS-SD800GBKNK9-D=	800GB Enterprise Performance SAS SSD (3X DWPD, SED) FIPS140-2
UCS-SD960GBKNK9-D=	960GB Enterprise Value SAS SSD (1X DWPD, SED) FIPS140-2
UCS-SD16TBKNK9-D=	1.6TB Enterprise performance SAS SSD (3X DWPD, SED) FIPS140-2
UCS-SD38TBKNK9-D=	3.8TB Enterprise Value SAS SSD (1X DWPD, SED) FIPS140-2
UCS-SD76TBKNK9-D=	7.6TB Enterprise value SAS SSD (1X DWPD, SED-FIPS) FIPS140-2
UCS-SD16TBKANK9-D=	1.6TB 2.5" Enterprise performance 12GSAS SSD(3DWPD,SED-FIPS) FIPS140-2
UCS-SD38TBKANK9-D=	3.8TB 2.5" Enterprise value 12G SAS SSD (1DWPD, SED-FIPS) FIPS140-2
UCS-SD76TBKANK9-D=	7.6TB Enterprise value SAS SSD (1DWPD, SED-FIPS) FIPS140-2
UCS-SD960GM2NK9-D=	960GB SED SSD 1DWPD
UCS-SD19TEM2NK9-D=	1.9TB SED SSD 1DWPD
UCS-SD38TEM2NK9-D=	3.8TB SED SSD 1DWPD
UCS-SD76TEM2NK9-D=	7.6TB SED SSD 1DWPD

Table 21 Spare Parts





Product ID (PID)	Description
Drive Cables	
CBL-NVME-C240M7=  Note: You may need this cable if you are adding front NVMe drives to UCSC-C240-M7SX. This cable is required if front NVMe Qty is 1 or 2, and the system is configured with UCSC-RAID-HP or UCSC-RAID-SD-D, or without RAID controllers.	C240M7 NVMe CABLE; MB P-2 to HBPLN (NVMe 1-2)
CBL-FNVME-C240M7=  Note: You may need this cable if you are adding front NVMe drives to UCSC-C240-M7SX. This cable is required if front NVMe Qty is 3 or 4	C240M7 NVMe CABLE, MB P-4 to BP (NVMe 3-4)
CBL-SAS12-C240M7=  Note: Order this cable if you are adding UCSC-SAS-T-D to the server.	C240M7SX, Cable MB CPU1 P-2 to PB/PR1
CBL-SAS24-C240M7=  Note: Order this cable if you are adding UCSC-SAS-T-D to the server.	C240M7SX, Cable MB CPU1 P-1 to PB/PR2 & HDD 1-2
CBL-SCAPSD-C240-D=	CBL Super Cap for PB+ C240 M7
Drive Blanking Panel	
UCSC-BBLKD-M7=	UCS C-Series M7 SFF drive blanking panel
M.2 SATA SSD and M.2 RAID controller	
UCS-M2-240GB-D=	240GB M.2 SATA SSD
UCS-M2-960GB-D=	960GB M.2 SATA SSD
UCS-M2-240G-D=	240GB M.2 SATA SSD
UCS-M2-960G-D=	960GB M.2 SATA SSD
UCS-M2-I240GB-D=	240GB SATA M.2 SSD
UCS-M2-I480GB-D=	480GB SATA M.2 SSD
UCS-M2-HWRAID-D=	Cisco Boot optimized M.2 RAID controller (holds up to two M.2 SATA SSDs)

Table 21 Spare Parts

Product ID (PID)	Description
UCSC-M2EXT-240-D =	C240M7 2U M.2 Extender board
PCIe Cards	
Modular LAN on Motherboard (mLOM)	
UCSC-M-V5Q50G-D=	Cisco UCS VIC 15428 Quad Port 10/25G/50G CNA MLOM
UCSC-M-V5D200G-D=	Cisco UCS VIC 15238 Dual Port 40/100/200G CNA MLOM
Open Compute Project (OCP)	
UCSC-O-ID10GC-D=	Intel X710T2LOCPV3G1L 2x10GbE RJ45 OCP 3.0 NIC
Virtual Interface Cards (VICs)	
UCSC-P-V5Q50G-D=	Cisco UCS VIC 15425 Quad Port 10/25/50G CNA PCIE
UCSC-P-V5D200G-D=	Cisco UCS VIC 15235 Dual Port 40/100/200G CNA PCIE
Network Interface Cards (NICs)	
1GB NICs	
UCSC-P-IQ1GC=	Cisco-Intel I710-T4L 4x1GBASE-T NIC
10GB NICs	
UCSC-PCIEID10GF-D=	Intel X710-DA2 Dual Port 10Gb SFP+ NIC
UCSC-PCIEIQ10GF-D=	Intel X710 quad-port 10G SFP+ NIC
UCSC-P-ID10GC-D=	Cisco-Intel X710T2LG 2x10GBE RJ45 PCIe NIC
UCSC-P-IQ10GC-D=	Cisco-Intel X710T4LG 4x10GBE RJ45 PCIe NIC
25GB NICs	
UCSC-P-I8D25GF-D=	Cisco-Intel E810XXVDA2 2x25/10GBE SFP28 PCIe NIC
UCSC-P-I8Q25GF-D=	Cisco-Intel E810XXVDA4L 4x25/10GBE SFP28 PCIe NIC
100GB NICs	
UCSC-P-MCD100GF-D=	Cisco-MLNX MCX623106AC-CDAT 2x100GbE QSFP56 PCIe NIC (with Crypto)
UCSC-P-MDD100GF-D=	Cisco-MLNX MCX623106AS-CDAT 2x100GbE QSFP56 PCIe NIC
UCSC-P-I8D100GF-D=	Cisco-Intel E810CQDA2 2x100 GbE QSFP28 PCIe NIC
Host Bus Adapters (HBAs)	
UCSC-P-Q6D32GF-D=	Cisco-QLogic QLE2772 2x32GFC Gen 6 Enhanced PCIe HBA
UCSC-P-B7D32GF-D=	Cisco-Emulex LPe35002-M2-2x32GFC Gen 7 PCIe HBA
UCSC-PCIEQD16GF-D=	Qlogic QLE2692 dual-port 16G FC HBA
UCSC-PCIEBD16GF-D=	Emulex LPe31002 dual port 16G FC HBA
UCSC-P-Q7D64GF=	Cisco-QLogic QLE2872, 2x64GFC Gen 7 PCIe HBA
External Storage HBA	
UCSC-9500-8E-D=	Cisco 12G 9500-8e 12G SAS HBA for external JBOD attach
OCP KIT	
UCSC-OCP3-KIT=	C2XX OCP 3.0 Interposer W/Mech Assy

Table 21 Spare Parts

Product ID (PID)	Description
GPUs	
<ul style="list-style-type: none"> ■ If the system was previously configured as GPU ready node, low profile heatsink and GPU air baffles are already included. Customer may need order airblockers to install on the risers. ■ If the system was not previously configured as GPU ready node, they will need order low profile heatsinks, thermal paste, GPU airduct and airblockers. 	
UCSC-GPU-A30-D=	TESLA A30, PASSIVE, 180W, 24GB
UCSC-GPU-A40-D=	TESLA A40 RTX, PASSIVE, 300W, 48GB
UCSC-GPUA100-80-D=	TESLA A100, PASSIVE, 300W, 80GB
UCSC-GPU-A16-D=	NVIDIA A16 PCIE 250W 4X16GB
UCSC-GPU-FLEX170=	Intel GPU Flex 170, Gen4x16, HHFL, 150W PCIe
UCSC-GPU-FLEX140=	Intel GPU Flex 140, Gen4x8, HHHL, 75W PCIe
UCSC-GPU-H100-80=	NVIDIA H100: 350W, 80GB, 2-slot FHFL GPU
UCSC-GPU-L40=	NVIDIA L40: 300W, 48GB, 2-slot FHFL GPU
UCSC-GPU-L4=	NVIDIA L4:70W, 24GB, 1-slot HHHL GPU
GPU Accessories	
UCSC-HSLP-C220M7=	UCS C220 M7 Heatsink & C240 GPU Heatsink
UCSC-RISAB-24XM7=	UCS C-Series M7 2U Air Blocker GPU only
UCSC-GPUAD-C240M7=	GPU AIR DUCT FOR C240M7
UCS-P100CBL-240-D=	C240 NVIDIA P100 /A100 /A40 / A16 / A30 Cable
UCS-M10CBL-C240M7=	C240 GPU Power Cable for the UCSC-GPU-FLEX170
CBL-G5GPU-C240M7=	C240M7 PCIe CEM compliant 12VHPWR power cable(upto 450W)
CBL-L40GPU-C240M7=	C240M7 PCIe CEM compliant 12VHPWR power cable(upto 300W)
GPU License	
NV-GRDWK-1-D5S=	Quadro Perpetual Lic - NVIDIA vDWS 1CCU; 5Yr SUMS Req
NV-GRDVA-1-D5S=	GRID Perpetual Lic - NVIDIA VDI APPs 1CCU; 5Yr SUMS Reqd
NV-GRDPC-1-D5S=	GRID Perpetual Lic - NVIDIA VDI PC 1CCU; 5Yr SUMS Reqd
NV-GRD-EDP-D5S=	EDU - Quadro Perpetual Lic - NVIDIA vDWS 1CCU; 5Yr SUMS Reqd
NV-GRID-WKP-D5YR=	NVIDIA Quadro Production SUMS - vDWS 1CCU - 5 Year
NV-GRID-VAP-D5YR=	NVIDIA GRID Production SUMS - VDI Apps 1CCU - 5 Year
NV-GRID-PCP-D5YR=	NVIDIA GRID Production SUMS - VDI PC 1CCU - 5 Year
NV-GRID-EDP-D5YR=	EDU - NVIDIA Quadro vDWS Production SUMS - 1CCU - 5 Year
NV-GRID-WKS-D1YR=	NVIDIA Quadro SW Subscription - vDWS 1CCU - 1 Year
NV-GRID-WKS-D3YR=	NVIDIA Quadro SW Subscription - vDWS 1CCU - 3 Year
NV-GRID-WKS-D4YR=	NVIDIA Quadro SW Subscription - vDWS 1CCU - 4 Year
NV-GRID-WKS-D5YR=	NVIDIA Quadro SW Subscription - vDWS 1CCU - 5 Year
NV-GRID-PCS-D1YR=	NVIDIA GRID Software Subscription - VDI PC 1CCU - 1 Year
NV-GRID-PCS-D3YR=	NVIDIA GRID Software Subscription - VDI PC 1CCU - 3 Year
NV-GRID-PCS-D4YR=	NVIDIA GRID Software Subscription - VDI PC 1CCU - 4 Year

Table 21 Spare Parts

Product ID (PID)	Description
NV-GRID-PCS-D5YR=	NVIDIA GRID Software Subscription - VDI PC 1CCU - 5 Year
NV-GRID-VAS-D1YR=	NVIDIA GRID Software Subscription - VDI Apps 1CCU - 1 Year
NV-GRID-VAS-D3YR=	NVIDIA GRID Software Subscription - VDI Apps 1CCU - 3 Year
NV-GRID-VAS-D4YR=	NVIDIA GRID Software Subscription - VDI Apps 1CCU - 4 Year
NV-GRID-VAS-D5YR=	NVIDIA GRID Software Subscription - VDI Apps 1CCU - 5 Year
NV-GRID-EDS-D1YR=	EDU - NVIDIA Quadro vDWS SW Subscription - 1CCU - 1 Year
NV-GRID-EDS-D3YR=	EDU - NVIDIA Quadro vDWS SW Subscription - 1CCU - 3 Year
NV-GRID-EDS-D4YR=	EDU - NVIDIA Quadro vDWS SW Subscription - 1CCU - 4 Year
NV-GRID-EDS-D5YR=	EDU - NVIDIA Quadro vDWS SW Subscription - 1CCU - 5 Year
NV-VCS-D1Y=	NVIDIA vCompute Server Subscription - 1 GPU - 1 Year
NV-VCS-D3Y=	NVIDIA vCompute Server Subscription - 1 GPU - 3 Year
NV-VCS-D5Y=	NVIDIA vCompute Server Subscription - 1 GPU - 5 Year
Power Supply	
PSU (Input High Line 210VAC)	
UCSC-PSUV21050D-D=	Cisco UCS 1050W -48V DC Power Supply for Rack Server Platinum
UCSC-PSU1-1200W-D=	1200W Titanium power supply for C-Series Servers Titanium
UCSC-PSU1-1600W-D=	1600W AC power supply for C-Series servers Platinum
UCSC-PSU1-2300W-D=	2300W Power supply for C-series servers Titanium
PSU (Input Low Line 110VAC)	
UCSC-PSU1-1200W-D=	1200W Titanium power supply for C-Series Servers Titanium
UCSC-PSU1-2300W-D=	2300W Power supply for C-series servers Titanium
Power Cords	
NO-POWER-CORD=	ECO friendly green option, no power cable will be shipped
CAB-48DC40A8AWG-D=	C-Series -48VDC PSU Power Cord, 3.5M, 3 Wire, 8AWG, 40A
CAB-N5K6A-NA=	Power Cord, 200/240V 6A, North America
CAB-AC-L620-C13-D=	AC Power Cord, NEMA L6-20 - C13, 2M/6.5ft
CAB-C13-CBN=	CABASY,WIRE,JUMPER CORD, 27" L, C13/C14, 10A/250V
CAB-C13-C14-2M=	CABASY,WIRE,JUMPER CORD, PWR, 2 Meter, C13/C14,10A/250V
CAB-C13-C14-AC=	CORD,PWR,JMP,IEC60320/C14,IEC6 0320/C13, 3.0M
CAB-250V-10A-AR=	Power Cord, 250V, 10A, Argentina
CAB-9K10A-AU=	Power Cord, 250VAC 10A 3112 Plug, Australia
CAB-250V-10A-CN=	AC Power Cord - 250V, 10A - PRC
CAB-9K10A-EU=	Power Cord, 250VAC 10A CEE 7/7 Plug, EU
CAB-250V-10A-ID=	Power Cord, 250V, 10A, India
CAB-C13-C14-3M-IN=	Power Cord Jumper, C13-C14 Connectors, 3 Meter Length, India
CAB-C13-C14-IN=	Power Cord Jumper,C13-C14 Connectors,1.4 Meter Length, India
CAB-250V-10A-IS=	Power Cord, SFS, 250V, 10A, Israel
CAB-9K10A-IT=	Power Cord, 250VAC 10A CEI 23-16/VII Plug, Italy

Table 21 Spare Parts

Product ID (PID)	Description
CAB-9K10A-SW=	Power Cord, 250VAC 10A MP232 Plug, Switzerland
CAB-9K10A-UK=	Power Cord, 250VAC 10A BS1363 Plug (13 A fuse), UK
CAB-9K12A-NA=	Power Cord, 125VAC 13A NEMA 5-15 Plug, North America
CAB-250V-10A-BR =	Power Cord - 250V, 10A - Brazil
CAB-C13C142M-JP-D=	Power Cord C13-C14, 2M/6.5ft Japan PSE mark
CAB-9K10A-KOR=	Power Cord, 125VAC 13A KSC8305 Plug, Korea
CAB-ACTW=	AC Power Cord (Taiwan), C13, EL 302, 2.3M
CAB-JPN-3PIN=	Japan, 90-125VAC 12A NEMA 5-15 Plug, 2.4m
CAB-48DC40A-INT-D=	C-Series -48VDC PSU PWR Cord, 3.5M, 3 Wire, 8AWG, 40A (INT)
CAB-48DC-40A-AS-D=	C-Series -48VDC PSU PWR Cord, 3.5M, 3Wire, 8AWG, 40A (AS/NZ)
CAB-C19-CBN=	Cabinet Jumper Power Cord, 250 VAC 16A, C20-C19 Connectors
CAB-S132-C19-ISRL=	S132 to IEC-C19 14ft Israeli
CAB-IR2073-C19-AR=	IRSM 2073 to IEC-C19 14ft Argen
CAB-BS1363-C19-UK=	BS-1363 to IEC-C19 14ft UK
CAB-SABS-C19-IND=	SABS 164-1 to IEC-C19 India
CAB-C2316-C19-IT=	CEI 23-16 to IEC-C19 14ft Italy
CAB-L520P-C19-US =	NEMA L5-20 to IEC-C19 6ft US
CAB-US515P-C19-US=	NEMA 5-15 to IEC-C19 13ft US
CAB-US520-C19-US=	NEMA 5-20 to IEC-C19 14ft US
CAB-US620P-C19-US =	NEMA 6-20 to IEC-C19 13ft US
Rail Kit	
UCSC-RAIL-D=	Ball Bearing Rail Kit for C220 & C240 M6/M7 rack servers
UCSC-RAIL-NONE-D=	No rail kit option
UCSC-CMA-C240-D=	Reversible CMA for C240 M6/M7 ball bearing rail kit
Security	
UCSC-DLOM-01-D=	Dedicated Mode BIOS setting for C-Series Servers
UCSC-CCARD-01-D=	Cisco Card Mode BIOS setting for C-Series Servers
UCSX-TPM-002C-D=	Trusted Platform Module 2.0 for UCS servers
UCSC-INT-SW02-D=	C220 and C240 M7 Chassis Intrusion Switch
UCSX-TPM-OPT-OUT-D=	OPT OUT, TPM 2.0, TCG, FIPS140-2, CC EAL4+ Certified
Security	
UCSC-BZL-C240-D=	C240 M7 Security Bezel
Operating system and Software	
VMware vCenter	
VMW-VCS-STD-D1A =	VMware vCenter 7 Server Standard, 1 yr support required
VMW-VCS-STD-D3A=	VMware vCenter 7 Server Standard, 3 yr support required
VMW-VCS-STD-D5A=	VMware vCenter 7 Server Standard, 5 yr support required
VMW-VCS-FND-D1A=	VMware vCenter Server 7 Foundation (4 Host), 1 yr supp reqd

Table 21 Spare Parts

Product ID (PID)	Description
VMW-VCS-FND-D3A=	VMware vCenter Server 7 Foundation (4 Host), 3 yr supp reqd
VMW-VCS-FND-D5A=	VMware vCenter Server 7 Foundation (4 Host), 5 yr supp reqd
Microsoft Windows Server	
MSWS-22-ST16CD =	Windows Server 2022 Standard (16 Cores/2 VMs)
MSWS-22-ST16CD-NS=	Windows Server 2022 Standard (16 Cores/2 VMs) - No Cisco SVC
MSWS-22-DC16CD=	Windows Server 2022 Data Center (16 Cores/Unlimited VMs)
MSWS-22-DC16CD-NS=	Windows Server 2022 DC (16 Cores/Unlim VMs) - No Cisco SVC
MSWS-19-ST16CD=	Windows Server 2019 Standard (16 Cores/2 VMs)
MSWS-19-ST16CD-NS=	Windows Server 2019 Standard (16 Cores/2 VMs) - No Cisco SVC
MSWS-19-DC16CD=	Windows Server 2019 Data Center (16 Cores/Unlimited VMs)
MSWS-19-DC16CD-NS=	Windows Server 2019 DC (16 Cores/Unlim VMs) - No Cisco SVC
Red Hat	
RHEL-2S2V-D1A=	Red Hat Enterprise Linux (1-2 CPU,1-2 VN); 1-Yr Support Req
RHEL-2S2V-D3A=	Red Hat Enterprise Linux (1-2 CPU,1-2 VN); 3-Yr Support Req
RHEL-2S2V-D5A=	Red Hat Enterprise Linux (1-2 CPU,1-2 VN); 5-Yr Support Req
RHEL-VDC-2SUV-D1A=	RHEL for Virt Datacenters (1-2 CPU, Unlim VN) 1 Yr Supp Req
RHEL-VDC-2SUV-D3A=	RHEL for Virt Datacenters (1-2 CPU, Unlim VN) 3 Yr Supp Req
RHEL-VDC-2SUV-D5A=	RHEL for Virt Datacenters (1-2 CPU, Unlim VN) 5 Yr Supp Req
Red Hat Ent Linux/ High Avail/ Res Strg/ Scal	
RHEL-2S2V-D1S=	Red Hat Enterprise Linux (1-2 CPU,1-2 VN); Prem 1Yr SnS Reqd
RHEL-2S2V-D3S=	Red Hat Enterprise Linux (1-2 CPU,1-2 VN); Prem 3Yr SnS Reqd
RHEL-2S-HA-D1S=	RHEL High Availability (1-2 CPU); Premium 1-yr SnS Reqd
RHEL-2S-HA-D3S=	RHEL High Availability (1-2 CPU); Premium 3-yr SnS Reqd
RHEL-2S-RS-D1S=	RHEL Resilent Storage (1-2 CPU); Premium 1-yr SnS Reqd
RHEL-2S-RS-D3S=	RHEL Resilent Storage (1-2 CPU); Premium 3-yr SnS Reqd
RHEL-VDC-2SUV-D1S=	RHEL for Virt Datacenters (1-2 CPU, Unlim VN) 1 Yr SnS Reqd
RHEL-VDC-2SUV-D3S=	RHEL for Virt Datacenters (1-2 CPU, Unlim VN) 3 Yr SnS Reqd
Red Hat SAP	
RHEL-SAP-2S2V-D1S=	RHEL for SAP Apps (1-2 CPU, 1-2 VN); Prem 1-Yr SnS Reqd
RHEL-SAP-2S2V-D3S=	RHEL for SAP Apps (1-2 CPU, 1-2 VN); Prem 3-Yr SnS Reqd
RHEL-SAPSP-D3S=	RHEL SAP Solutions Premium - 3 Years
RHEL-SAPSS-D3S=	RHEL SAP Solutions Standard - 3 Years
VMware	
VMW-VSP-STD-D1A=	VMware vSphere 7 Std (1 CPU, 32 Core) 1-yr, Support Required
VMW-VSP-STD-D3A=	VMware vSphere 7 Std (1 CPU, 32 Core) 3-yr, Support Required
VMW-VSP-STD-D5A=	VMware vSphere 7 Std (1 CPU, 32 Core) 5-yr, Support Required
VMW-VSP-EPL-D1A=	VMware vSphere 7 Ent Plus (1 CPU, 32 Core) 1Yr, Support Reqd
VMW-VSP-EPL-D3A=	VMware vSphere 7 Ent Plus (1 CPU, 32 Core) 3Yr, Support Reqd
VMW-VSP-EPL-D5A=	VMware vSphere 7 Ent Plus (1 CPU, 32 Core) 5Yr, Support Reqd
SUSE	
SLES-2S2V-D1A=	SUSE Linux Enterprise Svr (1-2 CPU,1-2 VM); 1-Yr Support Req

Table 21 Spare Parts

Product ID (PID)	Description
SLES-2S2V-D3A=	SUSE Linux Enterprise Svr (1-2 CPU,1-2 VM); 3-Yr Support Req
SLES-2S2V-D5A=	SUSE Linux Enterprise Svr (1-2 CPU,1-2 VM); 5-Yr Support Req
SLES-2SUVM-D1A=	SUSE Linux Enterprise Svr (1-2 CPU,Unl VM) LP; 1Y Supp Req
SLES-2SUVM-D3A=	SUSE Linux Enterprise Svr (1-2 CPU,Unl VM) LP; 3Y Supp Req
SLES-2SUVM-D5A=	SUSE Linux Enterprise Svr (1-2 CPU,Unl VM) LP; 5Y Supp Req
SLES-2S-LP-D1A=	SUSE Linux Live Patching Add-on (1-2 CPU); 1yr Support Req
SLES-2S-LP-D3A=	SUSE Linux Live Patching Add-on (1-2 CPU); 3yr Support Req
SLES-2S2V-D1S=	SUSE Linux Enterprise Svr (1-2 CPU,1-2 VM); Prio 1-Yr SnS
SLES-2S2V-D3S=	SUSE Linux Enterprise Svr (1-2 CPU,1-2 VM); Prio 3-Yr SnS
SLES-2S2V-D5S=	SUSE Linux Enterprise Svr (1-2 CPU,1-2 VM); Prio 5-Yr SnS
SLES-2SUVM-D1S=	SUSE Linux Enterprise Svr (1-2 CPU,Unl VM) LP; Prio 1Y SnS
SLES-2SUVM-D3S=	SUSE Linux Enterprise Svr (1-2 CPU,Unl VM) LP; Prio 3Y SnS
SLES-2SUVM-D5S=	SUSE Linux Enterprise Svr (1-2 CPU,Unl VM) LP; Prio 5Y SnS
SLES-2S-HA-D1S=	SUSE Linux High Availability Ext (1-2 CPU); 1yr SnS
SLES-2S-HA-D3S=	SUSE Linux High Availability Ext (1-2 CPU); 3yr SnS
SLES-2S-HA-D5S=	SUSE Linux High Availability Ext (1-2 CPU); 5yr SnS
SLES-2S-GC-D1S=	SUSE Linux GEO Clustering for HA (1-2 CPU); 1yr Sns
SLES-2S-GC-D3S=	SUSE Linux GEO Clustering for HA (1-2 CPU); 3yr SnS
SLES-2S-GC-D5S=	SUSE Linux GEO Clustering for HA (1-2 CPU); 5yr SnS
SLES-2S-LP-D1S=	SUSE Linux Live Patching Add-on (1-2 CPU); 1yr SnS Required
SLES-2S-LP-D3S=	SUSE Linux Live Patching Add-on (1-2 CPU); 3yr SnS Required
SLES and SAP	
SLES-SAP-2S2V--D1S=	SLES for SAP Apps (1-2 CPU, 1-2 VM); Priority 1-Yr SnS
SLES-SAP-2S2V-D3S=	SLES for SAP Apps (1-2 CPU, 1-2 VM); Priority 3-Yr SnS
SLES-SAP-2S2V-D5S=	SLES for SAP Apps (1-2 CPU, 1-2 VM); Priority 5-Yr SnS
SLES-SAP-2S2V-D1A=	SLES for SAP Apps w/ HA (1-2 CPU, 1-2 VM); 1-Yr Support Reqd
SLES-SAP-2S2V-D3A=	SLES for SAP Apps w/ HA (1-2 CPU, 1-2 VM); 3-Yr Support Reqd
SLES-SAP-2S2V-D5A=	SLES for SAP Apps w/ HA (1-2 CPU, 1-2 VM); 5-Yr Support Reqd

Notes:

1. This part is included with the purchase of option or spare CPU or CPU processor kits.

TECHNICAL SPECIFICATIONS

Dimensions and Weight

Table 22 UCS C240 M7 Dimensions and Weight

Parameter	Value
Height	3.42 in. (8.7 cm)
Width (including slam latches)	16.9 in. (42.9 cm)
Depth	30 in. (76.2 cm)
Weight	
Weight with following options and no rail kit: 0* HDDs, 0* CPU (with Heat sink), 0* DIMM, 1* 2300W PSU, mLOM card, Riser Cage 1 (Without PCIe), Riser Cage 2 (Without PCIe), Riser Cage 3 (Without PCIe)	18.6 kgs = 41.01 lbs (NVMe SKU)
Weight with following options and including rail kit: 0* 2.5 HDDs, 0* CPU (with Heat sink), 0* DIMM, 1* 2300W PSU, mLOM, Riser Cage 1 (Without PCIe), Riser Cage 2 (Without PCIe), Riser Cage 3 (Without PCIe)	22.3 kgs = 49.16 lbs (NVMe SKU)
Weight with following options and no rail kit: 1* HDD, 1* CPU (with Heat sink), 1* DIMM, 1* 2300W PSU, mLOM card, Riser Cage 1 (Without PCIe), Riser Cage 2 (Without PCIe), Riser Cage 3 (Without PCIe)	19.4 kgs = 42.77 lbs (NVMe SKU)
Weight with following options and including rail kit: 1* 2.5 HDDs, 1* CPU (with Heat sink), 1* DIMM, 1* 2300W PSU, mLOM, Riser Cage 1 (Without PCIe), Riser Cage 2 (Without PCIe), Riser Cage 3 (Without PCIe)	23.1 kgs = 50.93 lbs (NVMe SKU)
Weight with following options and no rail kit: 8* HDDs, 2* CPUs (with Heat sink), 32* DIMMs, 2* 2300W PSUs, mLOM card, Riser Cage 1 (Without PCIe), Riser Cage 2 (Without PCIe), Riser Cage 3 (Without PCIe)	23.5 kgs = 51.81 lbs (NVMe SKU)
Weight with following options and including rail kit: 8* 2.5 HDDs, 2* CPUs (with Heat sink), 32* DIMMs, 2* 2300W PSUs, mLOM, Riser Cage 1 (Without PCIe), Riser Cage 2 (Without PCIe), Riser Cage 3 (Without PCIe)	28.0 kgs = 61.73 lbs (NVMe SKU)
Weight with following options and no rail kit: 0* HDDs, 0* CPU (with Heat sink), 0* DIMM, 1* 2300W PSU, mLOM card, Riser Cage 1 (Without PCIe), Riser Cage 2 (Without PCIe), Riser Cage 3 (Without PCIe), 2* Raid Tray	19.2 kgs = 42.33 lbs (SAS SKU)
Weight with following options and including rail kit: 0* 2.5 HDDs, 0* CPU (with Heat sink), 0* DIMM, 1* 2300W PSU, 2* Raid Tray, mLOM, Riser Cage 1 (Without PCIe), Riser Cage 2 (Without PCIe), Riser Cage 3 (Without PCIe)	22.9 kgs = 50.49 lbs (NVMe SKU)
Weight with following options and no rail kit: 1* HDD, 1* CPU (with Heat sink), 1* DIMM, 1* 2300W PSU, mLOM card, Riser Cage 1 (Without PCIe), Riser Cage 2 (Without PCIe), Riser Cage 3 (Without PCIe), 2* Raid Tray	20 kgs = 44.09 lbs (NVMe SKU)

Table 22 UCS C240 M7 Dimensions and Weight

Parameter	Value
Weight with following options and including rail kit: 1* 2.5 HDDs, 1* CPU (with Heat sink), 1* DIMM, 1* 2300W PSU, 2* Raid Tray , mLOM, Riser Cage 1 (Without PCIe), Riser Cage 2 (Without PCIe), Riser Cage 3 (Without PCIe)	23.7 kgs = 52.25 lbs (NVMe SKU)
Weight with following options and no rail kit: 24* HDDs, 2* CPUs (with Heat sink), 32* DIMMs, 2* 2300W PSUs, mLOM card, Riser Cage 1 (Without PCIe), Riser Cage 2 (Without PCIe), Riser Cage 3 (Without PCIe), 2* Raid Tray	28.6kgs = 63.05 lbs (NVMe SKU)
Weight with following options and including rail kit: 24* 2.5 HDDs, 2* CPUs (with Heat sink), 32* DIMMs, 2* 2300W PSUs, 2* Raid Tray , mLOM, Riser Cage 1 (Without PCIe), Riser Cage 2 (Without PCIe), Riser Cage 3 (Without PCIe)	33.1 kgs = 72.97lbs (NVMe SKU)

Power Specifications

The server is available with the following types of power supplies:

- 1050 W V2 (DC) power supply (see [Table 23](#)).
- 1200 W (AC) power supply (see [Table 24](#))
- 1600 W (AC) power supply (see [Table 25](#))
- 2300 W (AC) power supply (see [Table 26](#))

Table 23 UCS C240 M7 SFF Power Specifications (1050 W V2 DC power supply)

Parameter	Specification
Input Connector	Molex 42820
Input Voltage Range (V rms)	-48
Maximum Allowable Input Voltage Range (V rms)	-40 to -72
Frequency Range (Hz)	NA
Maximum Allowable Frequency Range (Hz)	NA
Maximum Rated Output (W)	1050
Maximum Rated Standby Output (W)	36
Nominal Input Voltage (V rms)	-48
Nominal Input Current (A rms)	24
Maximum Input at Nominal Input Voltage (W)	1154
Maximum Input at Nominal Input Voltage (VA)	1154
Minimum Rated Efficiency (%) ¹	91
Minimum Rated Power Factor ¹	NA
Maximum Inrush Current (A peak)	15
Maximum Inrush Current (ms)	0.2
Minimum Ride-Through Time (ms) ²	5

Notes:

1. This is the minimum rating required to achieve 80 PLUS Platinum certification, see test reports published at <http://www.80plus.org/> for certified values
2. Time output voltage remains within regulation limits at 100% load, during input voltage dropout

Table 24 UCS C240 M7 1200 W (AC) Power Supply Specifications

Parameter	Specification			
Input Connector	IEC320 C14			
Input Voltage Range (Vrms)	100 to 240			
Maximum Allowable Input Voltage Range (Vrms)	90 to 264			
Frequency Range (Hz)	50 to 60			
Maximum Allowable Frequency Range (Hz)	47 to 63			
Maximum Rated Output (W) ¹	1100	1200		
Maximum Rated Standby Output (W)	48			
Nominal Input Voltage (Vrms)	100	120	208	230
Nominal Input Current (Arms)	12.97	10.62	6.47	5.84
Maximum Input at Nominal Input Voltage (W)	1300	1264	1343	1340
Maximum Input at Nominal Input Voltage (VA)	1300	1266	1345	1342
Minimum Rated Efficiency (%) ²	90	90	91	91
Minimum Rated Power Factor ²	0.97	0.97	0.97	0.97
Maximum Inrush Current (A peak)	20			
Maximum Inrush Current (ms)	0.2			
Minimum Ride-Through Time (ms) ³	12			

Notes:

1. Maximum rated output is limited to 1100W when operating at low-line input voltage (100-127V)
2. This is the minimum rating required to achieve 80 PLUS Titanium certification, see test reports published at <http://www.80plus.org/> for certified values
3. Time output voltage remains within regulation limits at 100% load, during input voltage dropout

Table 25 UCS C240 M7 1600 W (AC) Power Supply Specifications

Parameter	Specification			
Input Connector	IEC320 C14			
Input Voltage Range (V rms)	200 to 240			
Maximum Allowable Input Voltage Range (V rms)	180 to 264			
Frequency Range (Hz)	50 to 60			
Maximum Allowable Frequency Range (Hz)	47 to 63			
Maximum Rated Output (W)	1600			
Maximum Rated Standby Output (W)	36			
Nominal Input Voltage (V rms)	100	120	208	230
Nominal Input Current (A rms)	NA	NA	8.8	7.9
Maximum Input at Nominal Input Voltage (W)	NA	NA	1778	1758
Maximum Input at Nominal Input Voltage (VA)	NA	NA	1833	1813
Minimum Rated Efficiency (%) ¹	NA	NA	90	91
Minimum Rated Power Factor ²	NA	NA	0.97	0.97
Maximum Inrush Current (A peak)	30			
Maximum Inrush Current (ms)	0.2			
Minimum Ride-Through Time (ms) ²	12			

Notes:

1. This is the minimum rating required to achieve 80 PLUS Platinum certification, see test reports published at <http://www.80plus.org/> for certified values
2. Time output voltage remains within regulation limits at 100% load, during input voltage dropout

Table 26 UCS C240 M7 2300 W (AC) Power Supply Specifications

Parameter	Specification			
Input Connector	IEC320 C20			
Input Voltage Range (Vrms)	100 to 240			
Maximum Allowable Input Voltage Range (Vrms)	90 to 264			
Frequency Range (Hz)	50 to 60			
Maximum Allowable Frequency Range (Hz)	47 to 63			
Maximum Rated Output (W) ¹	2300			
Maximum Rated Standby Output (W)	36			
Nominal Input Voltage (Vrms)	100	120	208	230
Nominal Input Current (Arms)	13	11	12	10.8
Maximum Input at Nominal Input Voltage (W)	1338	1330	2490	2480
Maximum Input at Nominal Input Voltage (VA)	1351	1343	2515	2505
Minimum Rated Efficiency (%) ²	92	92	93	93
Minimum Rated Power Factor ²	0.99	0.99	0.97	0.97
Maximum Inrush Current (A peak)	30			
Maximum Inrush Current (ms)	0.2			
Minimum Ride-Through Time (ms) ³	12			

Notes:

1. Maximum rated output is limited to 1200W when operating at low-line input voltage (100-127V)
2. This is the minimum rating required to achieve 80 PLUS Titanium certification, see test reports published at <http://www.80plus.org/> for certified values
3. Time output voltage remains within regulation limits at 100% load, during input voltage dropout



NOTE: For configuration-specific power specifications, use the Cisco UCS Power Calculator at this URL: <http://ucspowercalc.cisco.com>

Environmental Specifications

The environmental specifications for Cisco UCS C240 M7 SFF server are listed in [Table 27](#).

Table 27 UCS C240 M7 Environmental Specifications

Parameter	Minimum
Operating Temperature	<p>5 °C to 45 °C (supports ASHRAE Class A4 and/or Class A3 and/or Class A2)</p> <p>ASHRAE Class A3 will be generic test profile unless otherwise specified by product engineering.</p> <p>System shall continue to operate with a single fan failure (one failed impeller in dual impeller housings) across the ASHRAE recommended operating range of 18 °C to 27 °C. While undesired, increased power consumption and/or acoustic noise is permitted during a fan fail event.</p>
Extended Operating Temperature	<p>5 °C to 40 °C (41 °F to 104 °F) with no direct sunlight</p> <p>Humidity condition: Uncontrolled, not to exceed 50% RH starting condition</p> <p>Derate the maximum temperature by 1 °C (33.8 °F) per every 305 meters of altitude above 900m</p>
Non-Operating Temperature	Dry bulb temperature of -40 °C to 65 °C (-40 °F to 149 °F)
Operating Relative Humidity	8% to 90% relative humidity, non-condensing, with maximum wet bulb 28 °C (82.4 °F) within operational temperature range of 5 °C to 50 °C (41 °F to 122 °F)
Non-Operating Relative Humidity	5% to 93% relative humidity, non-condensing, with a maximum wet bulb temperature of 28 °C across the 20 °C to 40 °C dry bulb range.
Maximum Operating Duration	Unlimited
Operating Altitude	A maximum elevation of 3050 meters (10,006 ft)
Non-Operating Altitude	An elevation of 0 to 12,000 meters (39,370 ft)
Sound Power level, Measure A-weighted per ISO7779 LWAd (Bels) Operation at 23 °C (73 °F)	<p>1RU: 5.5B</p> <p>2RU: 5.8B</p> <p>Racked product: 6.8B</p>
Sound Pressure level, Measure A-weighted per ISO7779 LpAm (dBA) Operation at 23 °C (73 °F)	<p>1RU: 40dB</p> <p>2RU: 43dB</p> <p>Racked product: 55dB</p>

Extended Operating Temperature Hardware Configuration Limits

Table 28 Cisco UCS C240 M7 Extended Operating Temperature Hardware Configuration Limits

Platform ¹	ASHRAE A3 (5°C to 40°C) ²	ASHRAE A4 (5°C to 45°C) ³
Processors:	155W+	155W+ and 105W+ (4 or 6 Cores)
Memory:	LRDIMMs	LRDIMMs
Storage:	M.2 SATA SSDs NVMe SSDs	M.2 SATA SSDs NVMe SSDs HDDs or SSDs (Rear Bays)
Peripherals:	PCIe NVMe SSDs GPUs	PCIe NVMe SSDs GPUs VICs (Slots 1 and 4) NICs (Slots 1 and 4) HBAs (Slots 1 and 4)

Notes:

1. Two PSUs are required and PSU failure is not supported
2. Non-Cisco UCS qualified peripherals and/or peripherals that consume more than 25W are not supported
3. High power or maximum power fan control policy must be applied

Compliance Requirements

The regulatory compliance requirements for C-Series servers are listed in [Table 29](#)

Table 29 UCS C-Series Regulatory Compliance Requirements

Parameter	Description
Regulatory Compliance	Products should comply with CE Markings per directives 2014/30/EU and 2014/35/EU
Safety	UL 60950-1 / 62368-1 CAN/CSA-C22.2 No. 60950-1, CAN/CSA-C22.2 No. 62368-1 EN 60950-1 / EN 62368-1 IEC 60950-1 / IEC 62368-1 AS/NZS 60950-1/62368.1 GB4943
EMC - Emissions	47CFR Part 15 (CFR 47) Class A AS/NZS CISPR32 Class A CISPR32 Class A EN55032 Class A ICES003 Class A VCCI Class A EN61000-3-2 EN61000-3-3 KN32 Class A CNS13438 Class A
EMC - Immunity	EN55024 CISPR24 EN300386 KN35



Americas Headquarters
Cisco Systems, Inc.
San Jose, CA

Asia Pacific Headquarters
Cisco Systems (USA) Pte. Ltd.
Singapore

Europe Headquarters
Cisco Systems International BV Amsterdam,
The Netherlands

Cisco has more than 200 offices worldwide. Addresses, phone numbers, and fax numbers are listed on the Cisco Website at www.cisco.com/go/offices.

Cisco and the Cisco Logo are trademarks of Cisco Systems, Inc. and/or its affiliates in the U.S. and other countries. A listing of Cisco's trademarks can be found at www.cisco.com/go/trademarks. Third party trademarks mentioned are the property of their respective owners. The use of the word partner does not imply a partnership relationship between Cisco and any other company. (1005R)

