



## **Cisco UCS C245 M6 Server Installation and Service Guide**

**First Published:** 2021-06-01

**Last Modified:** 2023-08-16

### **Americas Headquarters**

Cisco Systems, Inc.  
170 West Tasman Drive  
San Jose, CA 95134-1706  
USA  
<http://www.cisco.com>  
Tel: 408 526-4000  
800 553-NETS (6387)  
Fax: 408 527-0883





## CONTENTS

---

### PREFACE

<b>Preface</b>	<b>ix</b>
Bias-Free Documentation	<b>ix</b>
Introduction	<b>ix</b>
Communications, Services, and Additional Information	<b>xi</b>

---

### CHAPTER 1

<b>Overview</b>	<b>1</b>
Overview	<b>1</b>
External Features	<b>3</b>
Component Location	<b>6</b>
Summary of Server Features	<b>7</b>

---

### CHAPTER 2

<b>Installing the Server</b>	<b>11</b>
Preparing for Installation	<b>11</b>
Installation Warnings and Guidelines	<b>11</b>
Rack Requirements	<b>13</b>
Installing the Server in a Rack	<b>13</b>
Installing the Cable Management Arm (Optional)	<b>16</b>
Reversing the Cable Management Arm (Optional)	<b>17</b>
Initial Server Setup	<b>17</b>
Connecting to the Server Locally For Setup	<b>18</b>
Connecting to the Server Remotely For Setup	<b>19</b>
Setting Up the System With the Cisco IMC Configuration Utility	<b>20</b>
NIC Mode and NIC Redundancy Settings	<b>22</b>
Updating the BIOS and Cisco IMC Firmware	<b>23</b>
Accessing the System BIOS	<b>23</b>
Smart Access Serial	<b>24</b>

Smart Access USB 24

---

**CHAPTER 3**

**Maintaining the Server 27**

Status LEDs and Buttons 28

Front-Panel LEDs 28

Rear-Panel LEDs 31

Internal Diagnostic LEDs 32

Preparing For Component Installation 34

Required Equipment For Service Procedures 34

Shutting Down and Removing Power From the Server 34

Shutting Down Using the Power Button 34

Shutting Down Using The Cisco IMC GUI 35

Shutting Down Using The Cisco IMC CLI 35

Removing the Server Top Cover 35

Hot Swap vs Hot Plug 37

Removing and Replacing Components 38

Component Location 38

Replacing Front-Loading SAS/SATA Drives 40

Front-Loading SAS/SATA Drive Population Guidelines 40

4K Sector Format SAS/SATA Drives Considerations 41

Setting Up UEFI Mode Booting in the BIOS Setup Utility 41

Setting Up UEFI Mode Booting in the Cisco IMC GUI 42

Replacing a Front-Loading SAS/SATA Drive 42

Replacing Front-Loading NVMe SSDs 43

Front-Loading NVMe SSD Population Guidelines 44

Front-Loading NVMe SSD Requirements and Restrictions 44

Enabling Hot-Plug Support in the System BIOS 44

Enabling Hot-Plug Support Using the BIOS Setup Utility 44

Enabling Hot-Plug Support Using the Cisco IMC GUI 45

Replacing a Front-Loading NVMe SSD 45

Replacing Rear-Loading NVMe SSDs 46

Rear-Loading NVMe SSD Population Guidelines 46

Rear-Loading NVMe SSD Requirements and Restrictions 47

Replacing a Rear-Loading NVMe SSD 47

Replacing Fan Modules	49
Replacing CPUs and Heatsinks	51
CPU Configuration Rules	51
Tools Required For CPU Replacement	51
Replacing a CPU and Heatsink	51
Additional CPU-Related Parts to Order with RMA Replacement CPUs or RMA Nodes	58
Replacing Memory DIMMs	59
DIMM Population Rules and Memory Performance Guidelines	59
Replacing DIMMs	66
Replacing a Mini-Storage Module	67
Replacing a Mini-Storage Module Carrier	67
Replacing an M.2 SSD in a Mini-Storage Carrier For M.2	68
Replacing a USB Drive	69
Enabling or Disabling the Internal USB Port	70
Replacing the RTC Battery	71
Replacing Power Supplies	72
Installing DC Power Supplies (First Time Installation)	73
Replacing AC Power Supplies	74
Replacing DC Power Supplies	75
Grounding for DC Power Supplies	76
Replacing a PCIe Riser	77
Replacing NVMe Cable	78
Replacing a PCIe Card	86
PCIe Slot Specifications	86
Replacing a PCIe Card	88
Cisco Virtual Interface Card (VIC) Considerations	90
Replacing an mLOM Card	92
Replacing a SAS Storage Controller Card (RAID or HBA)	92
Storage Controller Card Firmware Compatibility	93
Replacing a SAS Storage Controller Card (RAID or HBA)	93
Replacing the Supercap (RAID Backup)	95
Replacing a Boot-Optimized M.2 RAID Controller Module	96
Cisco Boot-Optimized M.2 RAID Controller Considerations	96
Replacing a Cisco Boot-Optimized M.2 RAID Controller	97

- Replacing a Chassis Intrusion Switch 99
- Installing a Trusted Platform Module (TPM) 101
  - TPM Considerations 101
  - Installing and Enabling a TPM 101
    - Installing TPM Hardware 101
    - Enabling the TPM in the BIOS 103
- Removing the PCB Assembly (PCBA) 103
- Service Headers and Jumpers 105
  - Using the BIOS Recovery Header (SW4, Pins 5 - 17) 106
    - Procedure 1: Reboot With bios.cap Recovery File 106
    - Procedure 2: Use BIOS Recovery Header and bios.cap File 107
  - Using the Clear BIOS Password Header (SW4, Pins 6 - 18) 108
  - Using the Clear CMOS Header (SW4, Pins 9 - 21) 108
  - Using the Boot Alternate Cisco IMC Image Header (CN4, Pins 1 - 2) 109
  - Using the System Firmware Secure Erase Header (CN4, Pins 3 - 4) 110

---

**APPENDIX A**

- Server Specifications 111**
  - Physical Specifications 111
  - Environmental Specifications 111
  - Power Specifications 112
    - 770 W AC Power Supply 113
    - 1050 W AC Power Supply 113
    - 1200 W AC Power Supply 114
    - 1600 W AC Power Supply 115
    - 2300 W AC Power Supply 115
    - 1050 W DC Power Supply 116
  - Power Cord Specifications 117

---

**APPENDIX B**

- GPU Installation 119**
  - Server Firmware Requirements 119
  - GPU Card Configuration Rules 119
  - Requirement For All GPUs: Memory-Mapped I/O Greater Than 4 GB 120
  - Installing a Single-Wide GPU Card 121
  - Installing a Double-Wide GPU Card 122

Using NVIDIA GRID License Server For P-Series and T-Series GPUs	126
NVIDIA GRID License Server Overview	126
Registering Your Product Activation Keys With NVIDIA	127
Downloading the GRID Software Suite	128
Installing NVIDIA GRID License Server Software	128
Installing GRID License Server on Windows	128
Installing GRID License Server on Linux	129
Installing GRID Licenses From the NVIDIA Licensing Portal to the License Server	130
Reading Your License Server's MAC Address	130
Installing Licenses From the Licensing Portal	130
Viewing Available GRID Licenses	131
Viewing Current License Usage	131
Managing GRID Licenses	131
Using gpumodeswitch	132
Installing Drivers to Support the GPU Cards	133

---

**APPENDIX C**

<b>Storage Controller Considerations</b>	<b>135</b>
Supported Storage Controllers and Cables	135
Storage Controller Card Firmware Compatibility	136
RAID Backup (Supercap)	136
Write-Cache Policy for Cisco 12G SAS Modular RAID Controllers	136
Mixing Drive Types in RAID Groups	137
Storage Controller Cable Connectors and Backplanes	137







## Preface

---

This preface contains the following topics:

- [Bias-Free Documentation, on page ix](#)
- [Introduction, on page ix](#)
- [Communications, Services, and Additional Information, on page xi](#)

## Bias-Free Documentation



---

**Note** The documentation set for this product strives to use bias-free language. For purposes of this documentation set, bias-free is defined as language that does not imply discrimination based on age, disability, gender, racial identity, ethnic identity, sexual orientation, socioeconomic status, and intersectionality. Exceptions may be present in the documentation due to language that is hardcoded in the user interfaces of the product software, language used based on standards documentation, or language that is used by a referenced third-party product.

---

## Introduction

THE SPECIFICATIONS AND INFORMATION REGARDING THE PRODUCTS IN THIS MANUAL ARE SUBJECT TO CHANGE WITHOUT NOTICE. ALL STATEMENTS, INFORMATION, AND RECOMMENDATIONS IN THIS MANUAL ARE BELIEVED TO BE ACCURATE BUT ARE PRESENTED WITHOUT WARRANTY OF ANY KIND, EXPRESS OR IMPLIED. USERS MUST TAKE FULL RESPONSIBILITY FOR THEIR APPLICATION OF ANY PRODUCTS.

THE SOFTWARE LICENSE AND LIMITED WARRANTY FOR THE ACCOMPANYING PRODUCT ARE SET FORTH IN THE INFORMATION PACKET THAT SHIPPED WITH THE PRODUCT AND ARE INCORPORATED HEREIN BY THIS REFERENCE. IF YOU ARE UNABLE TO LOCATE THE SOFTWARE LICENSE OR LIMITED WARRANTY, CONTACT YOUR CISCO REPRESENTATIVE FOR A COPY.

The following information is for FCC compliance of Class A devices: This equipment has been tested and found to comply with the limits for a Class A digital device, pursuant to part 15 of the FCC rules. These limits are designed to provide reasonable protection against harmful interference when the equipment is operated

in a commercial environment. This equipment generates, uses, and can radiate radio-frequency energy and, if not installed and used in accordance with the instruction manual, may cause harmful interference to radio communications. Operation of this equipment in a residential area is likely to cause harmful interference, in which case users will be required to correct the interference at their own expense.

The following information is for FCC compliance of Class B devices: This equipment has been tested and found to comply with the limits for a Class B digital device, pursuant to part 15 of the FCC rules. These limits are designed to provide reasonable protection against harmful interference in a residential installation. This equipment generates, uses and can radiate radio frequency energy and, if not installed and used in accordance with the instructions, may cause harmful interference to radio communications. However, there is no guarantee that interference will not occur in a particular installation. If the equipment causes interference to radio or television reception, which can be determined by turning the equipment off and on, users are encouraged to try to correct the interference by using one or more of the following measures:

- Reorient or relocate the receiving antenna.
- Increase the separation between the equipment and receiver.
- Connect the equipment into an outlet on a circuit different from that to which the receiver is connected.
- Consult the dealer or an experienced radio/TV technician for help.

Modifications to this product not authorized by Cisco could void the FCC approval and negate your authority to operate the product.

The Cisco implementation of TCP header compression is an adaptation of a program developed by the University of California, Berkeley (UCB) as part of UCB's public domain version of the UNIX operating system. All rights reserved. Copyright © 1981, Regents of the University of California.

NOTWITHSTANDING ANY OTHER WARRANTY HEREIN, ALL DOCUMENT FILES AND SOFTWARE OF THESE SUPPLIERS ARE PROVIDED "AS IS" WITH ALL FAULTS. CISCO AND THE ABOVE-NAMED SUPPLIERS DISCLAIM ALL WARRANTIES, EXPRESSED OR IMPLIED, INCLUDING, WITHOUT LIMITATION, THOSE OF MERCHANTABILITY, FITNESS FOR A PARTICULAR PURPOSE AND NONINFRINGEMENT OR ARISING FROM A COURSE OF DEALING, USAGE, OR TRADE PRACTICE.

IN NO EVENT SHALL CISCO OR ITS SUPPLIERS BE LIABLE FOR ANY INDIRECT, SPECIAL, CONSEQUENTIAL, OR INCIDENTAL DAMAGES, INCLUDING, WITHOUT LIMITATION, LOST PROFITS OR LOSS OR DAMAGE TO DATA ARISING OUT OF THE USE OR INABILITY TO USE THIS MANUAL, EVEN IF CISCO OR ITS SUPPLIERS HAVE BEEN ADVISED OF THE POSSIBILITY OF SUCH DAMAGES.

Any Internet Protocol (IP) addresses and phone numbers used in this document are not intended to be actual addresses and phone numbers. Any examples, command display output, network topology diagrams, and other figures included in the document are shown for illustrative purposes only. Any use of actual IP addresses or phone numbers in illustrative content is unintentional and coincidental.

All printed copies and duplicate soft copies of this document are considered uncontrolled. See the current online version for the latest version.

Cisco has more than 200 offices worldwide. Addresses and phone numbers are listed on the Cisco website at [www.cisco.com/go/offices](http://www.cisco.com/go/offices).

Cisco and the Cisco logo are trademarks or registered trademarks of Cisco and/or its affiliates in the U.S. and other countries. To view a list of Cisco trademarks, go to this URL: <https://www.cisco.com/c/en/us/about/legal/trademarks.html>. Third-party trademarks mentioned are the property of their respective owners. The use of the word partner does not imply a partnership relationship between Cisco and any other company. (1721R)

# Communications, Services, and Additional Information

- To receive timely, relevant information from Cisco, sign up at [Cisco Profile Manager](#).
- To get the business impact you're looking for with the technologies that matter, visit [Cisco Services](#).
- To submit a service request, visit [Cisco Support](#).
- To discover and browse secure, validated enterprise-class apps, products, solutions and services, visit [Cisco Marketplace](#).
- To obtain general networking, training, and certification titles, visit [Cisco Press](#).
- To find warranty information for a specific product or product family, access [Cisco Warranty Finder](#).

## Cisco Bug Search Tool

[Cisco Bug Search Tool](#) (BST) is a web-based tool that acts as a gateway to the Cisco bug tracking system that maintains a comprehensive list of defects and vulnerabilities in Cisco products and software. BST provides you with detailed defect information about your products and software.





## CHAPTER 1

# Overview

---

- [Overview, on page 1](#)
- [External Features, on page 3](#)
- [Component Location, on page 6](#)
- [Summary of Server Features, on page 7](#)

## Overview

Cisco UCS C245 M6 Server (UCSC-C245-M6SX) server is orderable in one Small form-factor (SFF) drives version, with 24-drive back-plane front panel configuration:

- Front-loading drive bays 1—24 support 2.5-inch SAS/SATA drives.
- Optionally, front-loading drive bays 1 to 4 support 2.5-inch NVMe SSDs (with optional front NVMe cables).
- Optionally, Risers 1B and 3B support up to four Gen4 NVMe SSDs (2 drives per riser).

Following PCIe Riser combinations are available:

- Riser 1—Supports Riser 1A and 1B. PCIe slots 1, 2, and 3 numbered bottom to top with the following options:
  - Riser 1A (UCSC-RIS1A-240M6)—Slot 1 PCIe supports full height, full length PCIe Add-in-card; Slot 2 PCIe supports full height, full length PCIe Add-in-card; Slot 3 PCIe supports full height, full length PCIe Add-in-card.
  - Riser 1B (UCSC-RIS1B-245M6) (Storage Option)—Slot 1 PCIe is disabled; Slot 2 supports 2.5-inch NVMe SSD; Slot 3 supports 2.5-inch NVMe SSD.
- Riser 2—Supports Riser 2A. PCIe slots 4, 5, and 6 numbered bottom to top with the following options:
  - Riser 2A (UCSC-RIS2A-240M6)—Slot 4, 5, and 6 PCIe support full height, full length PCIe Add-in-card.
- Riser 3—Supports Riser 3A, 3B and 3C. PCIe slots 7 and 8 numbered bottom to top with the following options:
  - Riser 3A (UCSC-RIS3A-240M6)—Slot 7 PCIe supports full height, full length PCIe Add-in-card; Slot 8 PCIe supports full height, full length PCIe Add-in-card.

- Riser 3B (UCSC-RIS3B-240M6)—Slot 7 supports 2.5-inch NVMe SSD; Slot 8 supports 2.5-inch NVMe SSD.
- Riser 3C (UCSC-RIS3C-240M6)—Slot 7 PCIe supports full height, full length PCIe Add-in-card.
- Network connectivity through either a dedicated modular LAN over motherboard card (mLOM) that accepts a series 14xxx Cisco virtual interface card (VIC) or a third-party NIC. These options are in addition to Intel x550 10Gbase-T mLOM ports built into the server motherboard.
- Or, one mLOM/VIC card that provides 10/25/40/50/100 Gbps. The following mLOMs are supported:
  - Cisco UCS VIC 15428 Quad Port CNA MLOM (UCSC-M-V5Q50G) supports:
    - a x16 PCIe Gen4 Host Interface to the rack server
    - four 10G/25G/50G SFP56 ports
    - 4GB DDR4 Memory, 3200 MHz
    - Integrated blower for optimal ventilation
  - Cisco UCS VIC 15425 Quad Port 10G/25G/50G SFP56 CNA PCIe (UCSC-P-V5Q50G)
    - a x16 PCIe Gen4 Host Interface to the rack server
    - Four 10G/25G/50G SFP+/SFP28/SFP56 ports
    - 4GB DDR4 Memory, 3200MHz
    - Integrated blower for optimal ventilation
    - Secure boot support
  - Cisco UCS VIC 15238 Dual Port 40/100G QSFP28 mLOM (UCSC-M-V5D200G) supports:
    - a x16 PCIe Gen4 Host Interface to the rack server
    - two 40G/100G QSFP28 ports
    - 4GB DDR4 Memory, 3200 MHz
    - Integrated blower for optimal ventilation
  - Cisco UCS VIC 15235 Dual Port 40G/100G/200G QSFP56 CNA PCIe (UCSC-P-V5D200G)
    - a x16 PCIe Gen4 Host Interface to the rack server
    - two 40G/100G/200G QSFP/QSFP28/QSFP56 ports
    - 4GB DDR4 Memory, 3200MHz
    - Integrated blower for optimal ventilation
    - Secure boot support
  - Cisco UCS VIC 1477 Dual Port 40/100G QSFP28 (UCSC-M-V100-04)
    - a x16 PCIe Gen3 Host Interface to the rack server
    - two 40G/100G QSFP28 ports

- 2GB DDR3 Memory, 1866 MHz
- Cisco UCS VIC 1467 Quad Port 10/25G SFP28 mLOM (UCSC-M-V25-04) supports:
  - a x16 PCIe Gen3 Host Interface to the rack server
  - four 10G/25G QSFP28 ports
  - 2GB DDR3 Memory, 1866 MHz

These options are in addition to Intel x550 10Gbase-T mLOM ports built into the server motherboard.

- The following virtual interface cards (VICs) are supported in addition to some third-party VICs:
  - Cisco UCS VIC 1455 quad port 10/25G SFP28 PCIe (UCSC-PCIE-C25Q-04=)
  - Cisco UCS VIC 1495 Dual Port 40/100G QSFP28 CNA PCIe (UCSC-PCIE-C100-042)

Cisco UCS C245 M6 Server (UCSC-C245-M6SN) server is also available as **GPU Ready Configuration** unit. The server is configured to accept GPU, but GPUs are not installed while placing the order.

**GPU Ready Configuration** units are shipped with low profile heatsink: UCSC-HSLP-C245M6 and UCSC-ADGPU-245M6 (GPU air duct).



---

**Note** **GPU Ready Configuration** should follow the same temperature limit as GPU configured unit.

You should select the GPU airduct PID to enable **GPU Ready Configuration**. Follow Cisco Commerce Workspace (CCW) rules for more details.

---

## External Features

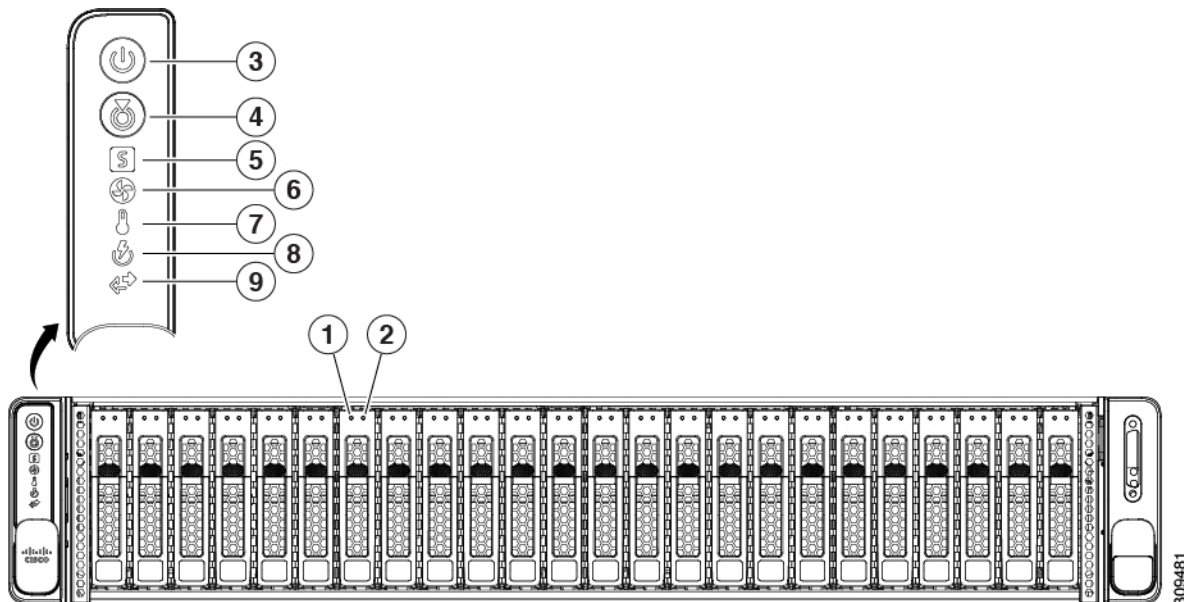
This topic shows the external features of the server.

For definitions of LED states, see [Front-Panel LEDs, on page 28](#).

### Cisco UCS C245 M6 Server (SFF Drives, 24-Drive) Front Panel Features

The following figure shows the front panel features of the server:

Figure 1: Cisco UCS C245 M6 Server (SFF Drives, 24-Drive) Front Panel



Cisco UCS C245 M6 Server features drive bays 1 to 24, which support SAS/SATA drives. Drive bays are numbered 1 through 24 from left to right. Optionally, front-loading drive bays 1 to 4 support 2.5-inch NVMe SSDs (with optional front NVMe cables). Other features are:

1	SAS/SATA drive fault LED	2	SAS/SATA drive activity LED
3	Power button/power status LED	4	Unit identification button/LED
5	System Status LED	6	Fan status LED
7	Temperature status LED	8	Power supply status LED
9	Network link activity LED		

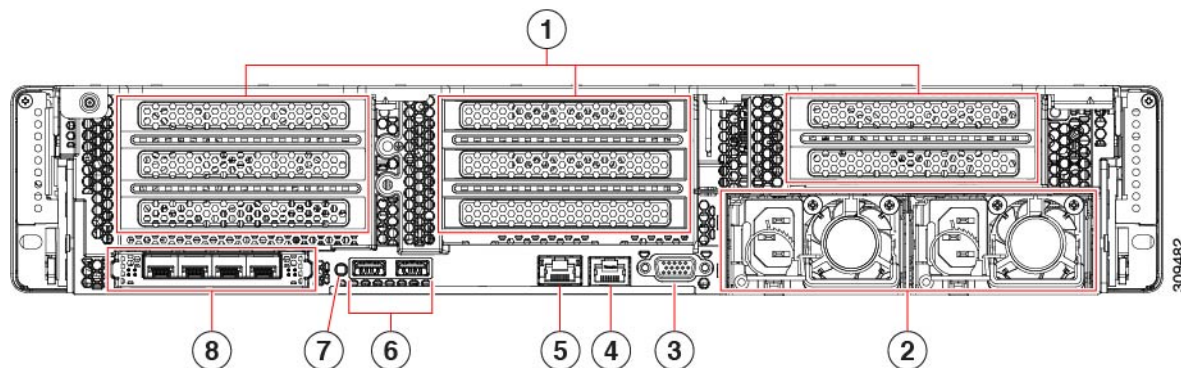
**Cisco UCS C245 M6 Server Rear Panel Features**

For definitions of LED states, see [Rear-Panel LEDs, on page 31](#).

The following configuration of the server has no additional storage installed, with possible combination explained in table:



Figure 2: Cisco UCS C245 M6 Server Rear Panel



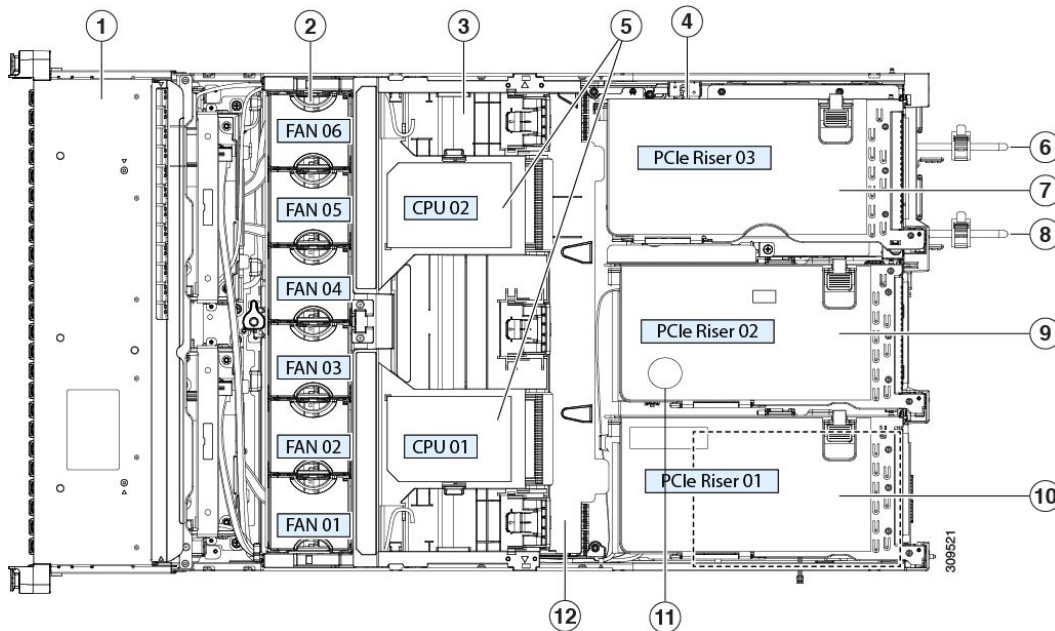
309482

<p><b>1</b></p>	<p>Cisco UCS C245 M6 Server supports three riser numbered 1 to 3 from left to right.</p> <p>Riser 1—Supports Riser 1A and 1B. PCIe slots 1, 2, and 3 numbered bottom to top with the following options:</p> <ul style="list-style-type: none"> <li>• Riser 1A—Slot 1 PCIe supports full height, full length PCIe Add-in-card; Slot 2 PCIe supports full height, full length PCIe Add-in-card; Slot 3 PCIe supports full height, full length PCIe Add-in-card.</li> <li>• Riser 1B (Storage Option)—Slot 1 PCIe is disabled; Slot 2 supports 2.5-inch NVMe SSD; Slot 3 supports 2.5-inch NVMe SSD.</li> </ul> <p>Riser 2—Supports Riser 2A. PCIe slots 4, 5, and 6 numbered bottom to top with the following options:</p> <ul style="list-style-type: none"> <li>• Riser 2A (UCSC-RIS2A-240M6)—Slot 4, 5, and 6 PCIe support full height, full length PCIe Add-in-card.</li> </ul> <p>Riser 3—Supports Riser 3A, 3B and 3C. PCIe slots 7 and 8 numbered bottom to top with the following options:</p> <ul style="list-style-type: none"> <li>• Riser 3A—Slot 7 PCIe supports full height, full length PCIe Add-in-card; Slot 8 PCIe supports full height, full length PCIe Add-in-card.</li> <li>• Riser 3B—Slot 7 supports 2.5-inch NVMe SSD; Slot 8 supports 2.5-inch NVMe SSD.</li> <li>• Riser 3C—Slot 7 PCIe supports full height, full length PCIe Add-in-card.</li> </ul>	
<p><b>2</b></p>	<p>Power supplies (two, redundant as 1+1) See <a href="#">Power Specifications, on page 112</a> for specifications and supported options.</p>	<p><b>3</b>      VGA video port (DB-15 connector)</p>
<p><b>4</b></p>	<p>Serial port (RJ-45 connector) COM 1, BMC or Host Serial access</p>	<p><b>5</b>      RJ45 BMC Dedicated Management Port</p>
<p><b>6</b></p>	<p>USB 3.0 ports, 2</p>	<p><b>7</b>      Rear unit identification button/LED</p>
<p><b>8</b></p>	<p>Modular LAN-on-motherboard (mLOM) card slot (x16)</p>	

# Component Location

This topic shows the locations of the field-replaceable components and service-related items. The view in the following figure shows the server with the top cover removed.

**Figure 3: Cisco UCS C245 M6 Server Serviceable Component Locations**



1	Front-loading drive bays.	2	Cooling fan modules (six, hot-swappable) Power supplies (hot-swappable when redundant as 1+1)
3	DIMM sockets on motherboard (16 per CPU) See <b>DIMM Population Rules and Memory Performance Guidelines</b> for DIMM slot numbering. <b>Note</b> An air baffle rests on top of the DIMM and CPUs when the server is operating. The air baffle is not displayed in this illustration.	4	Intrusion switch
5	CPU sockets, 2 CPU sockets are arranged side by side and labeled CPU1 and CPU2 next to the CPU socket.	6	Power Supply Unit (PSU) 1

7	<p>Riser 3—Supports Riser 3A, 3B and 3C. PCIe slots 7 and 8 numbered bottom to top with the following options:</p> <ul style="list-style-type: none"> <li>• Riser 3A—Slot 7 PCIe supports full height, full length PCIe Add-in-card; Slot 8 PCIe supports full height, full length PCIe Add-in-card.</li> <li>• Riser 3B—Slot 7 supports 2.5-inch NVMe SSD; Slot 8 supports 2.5-inch NVMe SSD.</li> <li>• Riser 3C—Slot 7 PCIe supports full height, full length PCIe Add-in-card.</li> </ul>	8	Power Supply Unit (PSU) 2
9	<p>Riser 2—Supports Riser 2A. PCIe slots 4, 5, and 6 numbered bottom to top with the following option:</p> <ul style="list-style-type: none"> <li>• Riser 2A—Slot 4, 5, and 6 PCIe support full height, full length PCIe Add-in-card.</li> </ul>	10	<p>Riser 1—Supports Riser 1A and 1B. PCIe slots 1, 2, and 3 numbered bottom to top with the following options:</p> <ul style="list-style-type: none"> <li>• Riser 1A—Slot 1 PCIe supports full height, full length PCIe Add-in-card; Slot 2 PCIe supports full height, full length PCIe Add-in-card; Slot 3 PCIe supports full height, full length PCIe Add-in-card.</li> <li>• Riser 1B (Storage Option)—Slot 1 PCIe is disabled; Slot 2 supports 2.5-inch NVMe SSD; Slot 3 supports 2.5-inch NVMe SSD.</li> </ul>
11	RTC Battery	12	Internal USB Port

## Summary of Server Features

The following table lists a summary of server features.

**Table 1: Feature Summary**

Feature	Description
Chassis	Two rack-unit (2RU) chassis
Processor	AMD SP3 Dual Socket (Rome Zen2 Core and Milan Zen3 Core)
Memory	3200 MT/s DDR4 DIMM sockets on the motherboard (16 DIMMS/8 channels each CPU)

Feature	Description
Baseboard management	<p>BMC, running Cisco Integrated Management Controller (Cisco IMC) firmware.</p> <p>Gigabit Ethernet switch port 0 as 10/100/1000base-T interface connect to RJ45 connector as CIMC management port.</p>
Network and management I/O	<p>Rear panel:</p> <ul style="list-style-type: none"> <li>• 1-Gb Ethernet dedicated management port, 1</li> <li>• One RS-232 serial port (RJ-45 connector)</li> <li>• One VGA video connector port (DB-15 connector)</li> <li>• Two USB 3.0 ports</li> </ul> <p>Front panel:</p> <ul style="list-style-type: none"> <li>• One front-panel keyboard/video/mouse (KVM) connector that is used with the KVM cable, which provides two USB 2.0, one VGA, and one DB-9 serial connector.</li> </ul>
Modular LOM	<p>x16 PCI Express Gen 3 connection, a SMBus (I2C), a 100M-Base-T link (MDI) interface and a RMII based NC-SI interface that support one wire Ethernet connection to the host.</p> <p>The panel interfaces support up to four 1G/10G ports with RJ45 connectors or SFP+ interfaces</p>
Power	<p>Two power supplies, redundant as 1+1, and cold redundancy:</p> <ul style="list-style-type: none"> <li>• 770W AC PSU</li> <li>• 1050W AC PSU</li> <li>• 1600W AC PSU</li> <li>• 2300W AC PSU</li> <li>• 1050W DC PSU (NEBS)</li> </ul>
Cooling	Six hot-swappable fan modules for front-to-rear cooling.

Feature	Description
PCIe I/O	<p>Six horizontal PCIe expansion slots on 3 PCIe riser assemblies.</p> <p>One Storage PCIe slot for Cisco Storage Card.</p> <p>One mLOM PCIe slot for Cisco Network Interface Card and OCP adapter</p> <p>See PCIe Slot Specifications, on page 84 for specifications of the slots.</p>
Storage, front-panel	<p>Server is orderable in one Small form-factor (SFF) drives version, with 24-drive back-plane front panel configuration:</p> <ul style="list-style-type: none"> <li>• Front-loading drive bays 1—24 support 2.5-inch SAS/SATA drives.</li> <li>• Optionally, front-loading drive bays 1 to 4 support 2.5-inch NVMe SSDs (with optional front NVMe cables).</li> <li>• Optionally, the three rear-loading drive bays support up to eight Gen4 NVMe SSDs.</li> </ul> <p>SAS/SATA drives are hot-swappable. NVMe SSDs are hot-pluggable, meaning that they must be shut down in the operating system before hot-removal.</p>
Storage, rear-panel	<p>Riser 1B—Slot 1 PCIe is disabled; Slot 2 supports 2.5-inch NVMe SSD; Slot 3 supports 2.5-inch NVMe SSD.</p> <p>Riser 3B—Slot 7 supports 2.5-inch NVMe SSD; Slot 8 supports 2.5-inch NVMe SSD.</p>
Storage, internal	<ul style="list-style-type: none"> <li>• One internal USB 3.0 slot</li> <li>• Mini-storage module socket, optionally with either: <ul style="list-style-type: none"> <li>• Dual M.2 2280 NVMe drive through Fort Point Module</li> <li>• Dual M.2 2280 SATA drive with hardware RAID</li> </ul> </li> </ul>
RAID backup	<p>The server has a mounting bracket on the removable air baffle for one SuperCap unit that is used with the Cisco modular RAID controller card.</p>

Feature	Description
GPU Support	<p>Riser 1A—Slot 1 PCIe supports full height, full length PCIe Add-in-card; Slot 2 PCIe supports full height, full length PCIe Add-in-card; Slot 3 PCIe supports full height, full length PCIe Add-in-card (For both Riser 1 and 2).</p> <p>Riser 3A (UCSC-RIS3A-240M6)—Slot 7 PCIe supports full height, full length PCIe Add-in-card; Slot 8 PCIe supports full height, full length PCIe Add-in-card (For Riser 3).</p>
Integrated video	Integrated VGA video.



## CHAPTER 2

# Installing the Server

---

- [Preparing for Installation](#), on page 11
- [Installing the Server in a Rack](#), on page 13
- [Initial Server Setup](#), on page 17
- [NIC Mode and NIC Redundancy Settings](#), on page 22
- [Updating the BIOS and Cisco IMC Firmware](#), on page 23
- [Accessing the System BIOS](#), on page 23
- [Smart Access Serial](#), on page 24
- [Smart Access USB](#), on page 24

## Preparing for Installation

### Installation Warnings and Guidelines



---

**Note**

Before you install, operate, or service a server, review the [Regulatory Compliance and Safety Information for Cisco UCS C-Series Servers](#) for important safety information.

---



---

**Warning****IMPORTANT SAFETY INSTRUCTIONS**

**This warning symbol means danger. You are in a situation that could cause bodily injury. Before you work on any equipment, be aware of the hazards involved with electrical circuitry and be familiar with standard practices for preventing accidents. Use the statement number provided at the end of each warning to locate its translation in the translated safety warnings that accompanied this device.**

Statement 1071

---



---

**Warning**

**To prevent the system from overheating, do not operate it in an area that exceeds the maximum recommended ambient temperature of: 35° C (95° F).**

Statement 1047

---



---

**Warning** The plug-socket combination must be accessible at all times, because it serves as the main disconnecting device.

Statement 1019

---



---

**Warning** This product relies on the building's installation for short-circuit (overcurrent) protection. Ensure that the protective device is rated not greater than: 250 V, 15 A.

Statement 1005

---



---

**Warning** Installation of the equipment must comply with local and national electrical codes.

Statement 1074

---



---

**Warning** This unit is intended for installation in restricted access areas. A restricted access area can be accessed only through the use of a special tool, lock, and key, or other means of security.

Statement 1017

---



---

**Caution** To ensure proper airflow it is necessary to rack the servers using rail kits. Physically placing the units on top of one another or “stacking” without the use of the rail kits blocks the air vents on top of the servers, which could result in overheating, higher fan speeds, and higher power consumption. We recommend that you mount your servers on rail kits when you are installing them into the rack because these rails provide the minimal spacing required between the servers. No additional spacing between the servers is required when you mount the units using rail kits.

---



---

**Caution** Avoid uninterruptible power supply (UPS) types that use ferroresonant technology. These UPS types can become unstable with systems such as the Cisco UCS, which can have substantial current draw fluctuations from fluctuating data traffic patterns.

---

When you are installing a server, use the following guidelines:

- Plan your site configuration and prepare the site before installing the server. See the [Cisco UCS Site Preparation Guide](#) for the recommended site planning tasks.
- Ensure that there is adequate space around the server to allow for accessing the server and for adequate airflow. The airflow in this server is from front to back.
- Ensure that the air-conditioning meets the thermal requirements listed in the [Environmental Specifications, on page 111](#).
- Ensure that the cabinet or rack meets the requirements listed in the [Rack Requirements, on page 13](#).



- Ensure that the site power meets the power requirements listed in the [Power Specifications, on page 112](#). If available, you can use an uninterruptible power supply (UPS) to protect against power failures.

## Rack Requirements

The rack must be of the following type:

- A standard 19-in. (48.3-cm) wide, four-post EIA rack, with mounting posts that conform to English universal hole spacing, per section 1 of ANSI/EIA-310-D-1992.
- A standard 19-in. (48.3-cm) wide, two-post EIA rack (can be used only with Extender Bracket Kit)
- The rack-post holes can be square 0.38-inch (9.6 mm), round 0.28-inch (7.1 mm), #12-24 UNC, or #10-32 UNC when you use the Cisco-supplied slide rails.
- The minimum vertical rack space per server must be two rack units (RUs), equal to 3.5 in. (88.9 mm).

### Supported Cisco Slide Rail Kits

The server supports the following rail kit options:

- Cisco part UCSC-RAILS-M5 (ball-bearing slide rail kit)

### Rack Installation Tools Required

The slide rails sold by Cisco Systems for this server do not require tools for installation.

### Slide Rail

The slide rails for this server have an adjustment range of 24 to 36 inches (610 to 914 mm).

## Installing the Server in a Rack

This section describes how to install the server in a rack using the rack kits that are sold by Cisco.



### Warning

**To prevent bodily injury when mounting or servicing this unit in a rack, you must take special precautions to ensure that the system remains stable. The following guidelines are provided to ensure your safety:**

**This unit should be mounted at the bottom of the rack if it is the only unit in the rack.**

**When mounting this unit in a partially filled rack, load the rack from the bottom to the top with the heaviest component at the bottom of the rack.**

**If the rack is provided with stabilizing devices, install the stabilizers before mounting or servicing the unit in the rack.**

Statement 1006

### Step 1

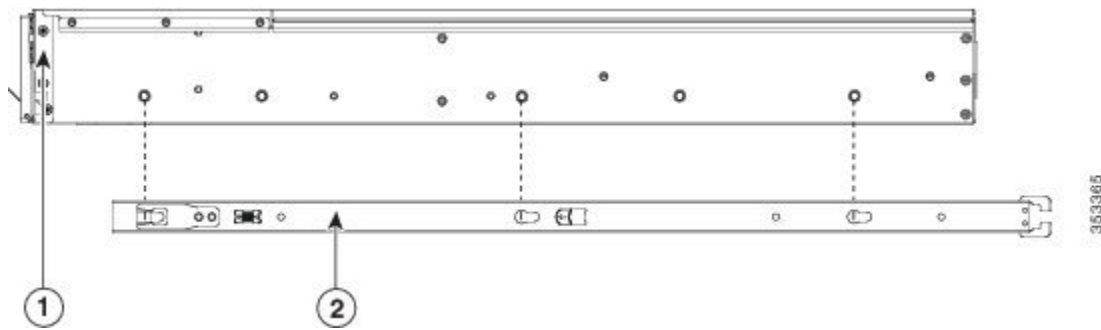
Inner and outer rails are shipped as an assembled unit. Separate the inner and the outer rail:

- a. Slide the internal rail out till it hits the internal stop.
- b. Slide the spring loaded locking button in the direction of the arrow (shown on the button) to release it from the outer rail and pull the rail out at the same time.

**Step 2** Attach the inner rails to the sides of the server:

- a) Align an inner rail with one side of the server so that the three keyed slots in the rail align with the three pegs on the side of the server.
- b) Set the keyed slots over the pegs, and then slide the rail toward the front to lock it in place on the pegs. The front slot has a metal clip that locks the front peg.
- c) Install the second inner rail to the opposite side of the server.

**Figure 4: Attaching the Inner Rail to the Side of the Server**

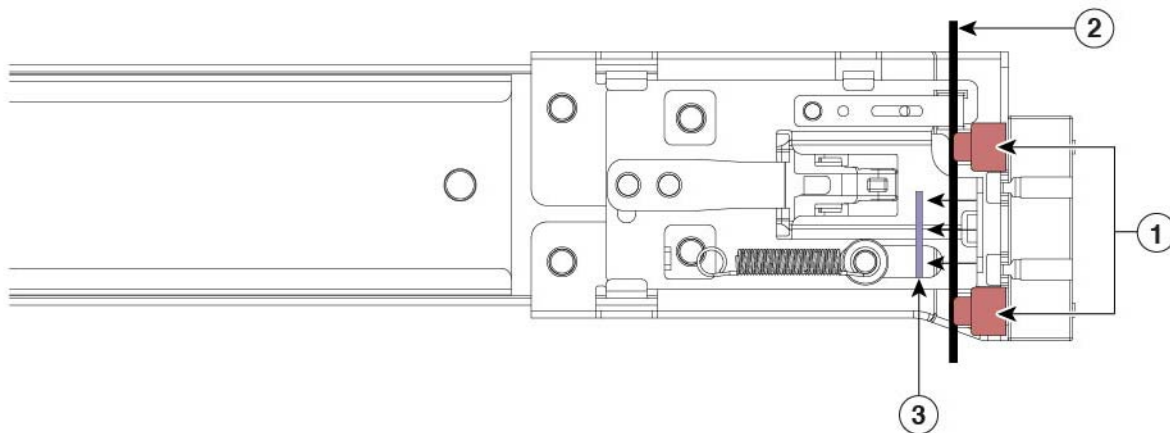


1	Front of server	2	Inner rail
---	-----------------	---	------------

**Step 3** Open the front securing plate on both slide-rail assemblies. The front end of the slide-rail assembly has a spring-loaded securing plate that must be open before you can insert the mounting pegs into the rack-post holes.

On the *outside* of the assembly, push the green-arrow button toward the rear to open the securing plate.

**Figure 5: Front Securing Mechanism, Inside of Front End**



1	Front mounting pegs	3	Securing plate shown pulled back to the open position
2	Rack post between mounting pegs and opened securing plate	-	

**Step 4** Install the outer slide rails into the rack:

- a) Align one slide-rail assembly front end with the front rack-post holes that you want to use.

The slide rail front-end wraps around the outside of the rack post and the mounting pegs enter the rack-post holes from the outside-front. See [Figure 5: Front Securing Mechanism, Inside of Front End, on page 14](#).

**Note** The rack post must be between the mounting pegs and the *open* securing plate.

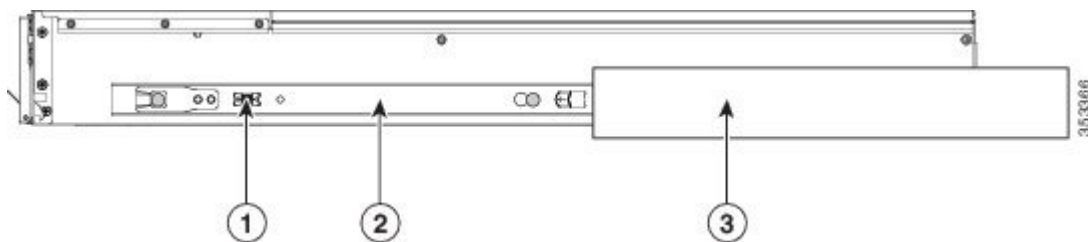
- b) Push the mounting pegs into the rack-post holes from the outside-front.
- c) Press the securing plate release button, marked PUSH. The spring-loaded securing plate closes to lock the pegs in place.
- d) Adjust the slide-rail length, and align the slide-rail assembly rear end with the corresponding rear rack-post holes. The slide rail must be level front-to-rear.
- The rear mounting pegs enter the rear rack-post holes from the *inside* of the rack post.
- e) Push the locking lever inwards and at the same time push the rear mounting pegs in the corresponding rear rack post holes.
- f) Once the mounting pegs are in place, release the locking lever.
- g) Attach the second slide-rail assembly to the opposite side of the rack. Ensure that the two slide-rail assemblies are at the same height and are level front-to-back.
- h) Pull the inner slide rails on each assembly out toward the rack front until they hit the internal stops and lock in place.

**Step 5** Insert the server into the slide rails:

**Caution** This server can weigh up to 40 pounds (18 kilograms) when fully loaded with components. We recommend that you use a minimum of two people or a mechanical lift when lifting the server. Attempting this procedure alone could result in personal injury or equipment damage.

- a) Align the rear ends of the inner rails that are attached to the server sides with the front ends of the empty slide rails on the rack.
- b) Push the inner rails into the slide rails on the rack until they stop at the internal stops.
- c) Slide the inner-rail release clip toward the rear on both inner rails, and then continue pushing the server into the rack until the front slam-latches engage with the rack posts.

**Figure 6: Inner-Rail Release Clip**



<b>1</b>	Inner-rail release clip	<b>3</b>	Outer slide rail attached to rack post
<b>2</b>	Inner rail attached to server and inserted into outer slide rail	-	

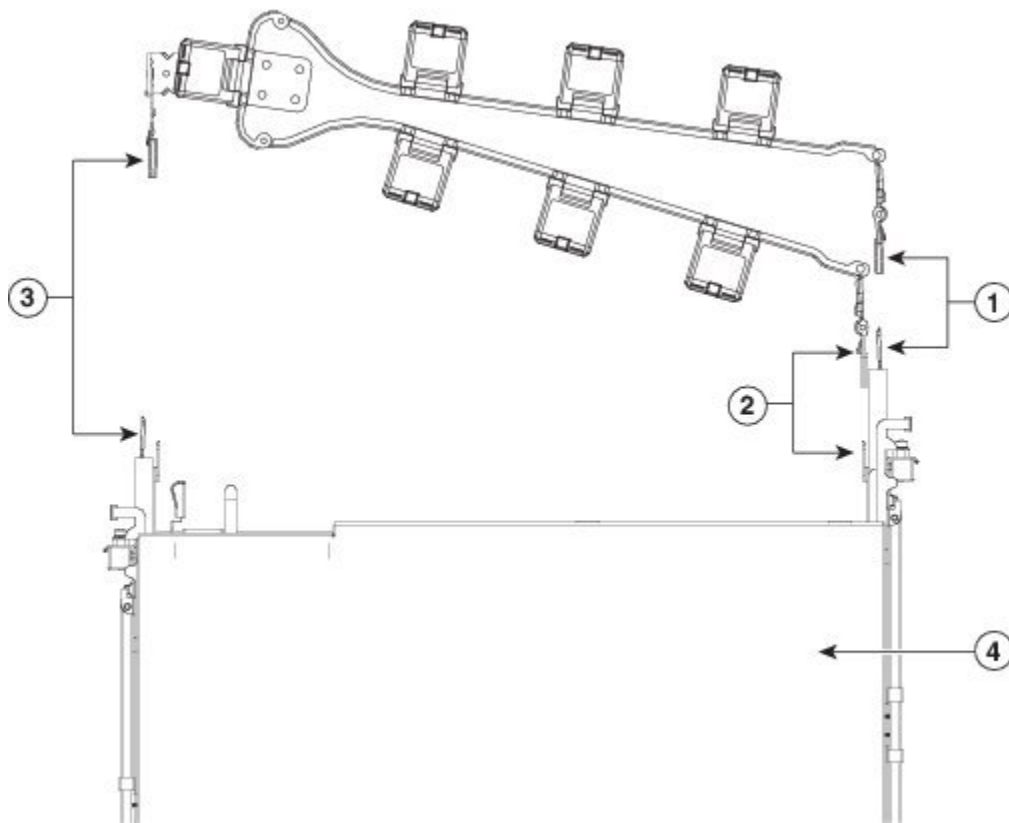
## Installing the Cable Management Arm (Optional)



**Note** The cable management arm (CMA) is reversible left-to-right. To reverse the CMA, see [Reversing the Cable Management Arm \(Optional\)](#), on page 17 before installation.

**Step 1** With the server pushed fully into the rack, slide the CMA tab of the CMA arm that is farthest from the server onto the end of the stationary slide rail that is attached to the rack post. Slide the tab over the end of the rail until it clicks and locks.

*Figure 7: Attaching the CMA to the Rear Ends of the Slide Rails*



1	CMA tab on arm farthest from server attaches to end of stationary outer slide rail.	3	CMA tab on width-adjustment slider attaches to end of stationary outer slide rail.
2	CMA tab on arm closest to the server attaches to end of inner slide rail attached to server.	4	Rear of server

**Step 2** Slide the CMA tab that is closest to the server over the end of the inner rail that is attached to the server. Slide the tab over the end of the rail until it clicks and locks

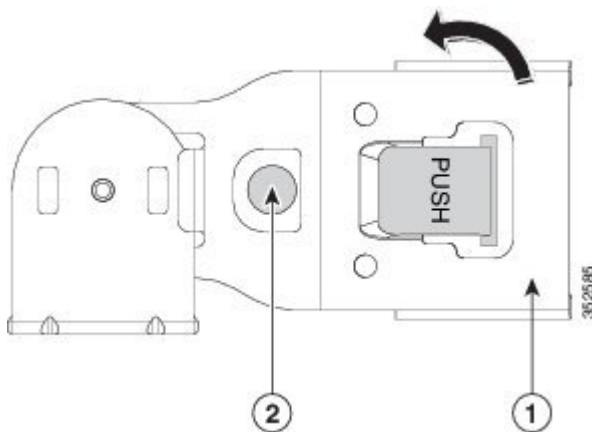
**Step 3** Pull out the width-adjustment slider that is at the opposite end of the CMA assembly until it matches the width of your rack.

- Step 4** Slide the CMA tab that is at the end of the width-adjustment slider onto the end of the stationary slide rail that is attached to the rack post. Slide the tab over the end of the rail until it clicks and locks.
- Step 5** Open the hinged flap at the top of each plastic cable guide and route your cables through the cable guides as desired.

## Reversing the Cable Management Arm (Optional)

- Step 1** Rotate the entire CMA assembly 180 degrees, left-to-right. The plastic cable guides must remain pointing upward.
- Step 2** Flip the tabs at the ends of the CMA arms so that they point toward the rear of the server.
- Step 3** Pivot the tab that is at the end of the width-adjustment slider. Depress and hold the metal button on the outside of the tab and pivot the tab 180 degrees so that it points toward the rear of the server.

*Figure 8: Reversing the CMA*



1	CMA tab on end of width-adjustment slider	2	Metal button on outside of tab
---	---	---	--------------------------------

## Initial Server Setup



**Note** This section describes how to power on the server, assign an IP address, and connect to server management when using the server in standalone mode.

### Server Default Settings

The server is shipped with these default settings:

- If the server does not have any VIC card, the default NIC mode is **Dedicated**. If the server has a VIC card in MLOM slot, or Riser 1 or Riser 2, then the default NIC mode is **Cisco Card**, but the VIC precedence first goes to MLOM, then Riser 1, and then Riser 2.

If you want to use the dedicated management ports to access Cisco IMC, you can connect to the server and change the NIC mode as described in [Setting Up the System With the Cisco IMC Configuration Utility, on page 20](#).

- In *Dedicated* mode, NIC redundancy is set to *None*. In *Cisco Card* mode, the NIC redundancy is set to *Active-Active*. All Ethernet ports are utilized simultaneously.
- DHCP is enabled.
- IPv4 and IPv6 are enabled.

### Connection Methods

There are two methods for connecting to the system for initial setup:

- Local setup—Use this procedure if you want to connect a keyboard and monitor directly to the system for setup. This procedure can use the VGA and USB ports on the front of the server.
- Remote setup—Use this procedure if you want to perform setup through your dedicated management LAN.




---

**Note** To configure the system remotely, you must have a DHCP server on the same network as the system. Your DHCP server must be preconfigured with the range of MAC addresses for this server node. The MAC address is printed on a label that is on the pull-out asset tag on the front panel. This server node has a range of six MAC addresses assigned to the Cisco IMC. The MAC address printed on the label is the beginning of the range of six contiguous MAC addresses.

---

## Connecting to the Server Locally For Setup

This procedure requires the following equipment:

- VGA monitor
- USB keyboard
- Supported USB cable and VGA DB-15 cable

---

**Step 1** Attach a power cord to each power supply in your server, and then attach each power cord to a grounded AC power outlet.

If you are using DC power supplies, see [Installing DC Power Supplies \(First Time Installation\), on page 73](#).

Wait for approximately two minutes to let the server boot to standby power during the first bootup. You can verify system power status by looking at the system Power Status LED on the front panel. The system is in standby power mode when the LED is amber.

**Step 2** Connect a USB keyboard and mouse, and VGA monitor to the corresponding connectors on the front panel.

**Step 3** Open the Cisco IMC Configuration Utility:

- Press and hold the front panel power button for four seconds to boot the server.
- During bootup, press **F8** when prompted to open the Cisco IMC Configuration Utility.

**Note** The first time that you enter the Cisco IMC Configuration Utility, you are prompted to change the default password. The default password is *password*. **Strong Password** feature is enabled.

Following are the requirements for **Strong Password**:

- The password can have minimum 8 characters; maximum 14 characters.
- The password must not contain the user name.
- The password must contain characters from three of the following four categories:
  - English uppercase letters (A through Z)
  - English lowercase letters (a through z)
  - Base 10 digits (0 through 9)
  - Non-alphabetic characters !, @, #, \$, %, ^, &, \*, -, \_, =, “

**Step 4** Continue with [Setting Up the System With the Cisco IMC Configuration Utility, on page 20](#).

---

## Connecting to the Server Remotely For Setup

This procedure requires the following equipment:

- One RJ-45 Ethernet cable that is connected to your management port.

### Before you begin



**Note** To configure the system remotely, you must have a DHCP server on the same network as the system. Your DHCP server must be preconfigured with the range of MAC addresses for this server node. The MAC address is printed on a label that is on the pull-out asset tag on the front panel. This server node has a range of six MAC addresses assigned to the Cisco IMC. The MAC address printed on the label is the beginning of the range of six contiguous MAC addresses.

---

**Step 1** Attach a power cord to each power supply in your server, and then attach each power cord to a grounded AC power outlet. If you are using DC power supplies, see [Installing DC Power Supplies \(First Time Installation\), on page 73](#).

Wait for approximately two minutes to let the server boot to standby power during the first bootup. You can verify system power status by looking at the system Power Status LED on the front panel. The system is in standby power mode when the LED is amber.

**Step 2** Plug your management cable into the dedicated management port on the rear panel.

**Step 3** Allow your preconfigured DHCP server to assign an IP address to the server node.

**Step 4** Use the assigned IP address to access and log in to the Cisco IMC for the server node. Consult with your DHCP server administrator to determine the IP address.

**Note** The default user name for the server is *admin*. The default password is *password*.

- Step 5** From the Cisco IMC Server Summary page, click **Launch KVM Console**. A separate KVM console window opens.
- Step 6** From the Cisco IMC Summary page, click **Power Cycle Server**. The system reboots.
- Step 7** Select the KVM console window.
- Note** The KVM console window must be the active window for the following keyboard actions to work.
- Step 8** When prompted, press **F8** to enter the Cisco IMC Configuration Utility. This utility opens in the KVM console window.
- Note** The first time that you enter the Cisco IMC Configuration Utility, you are prompted to change the default password. The default password is *password*. **Strong Password** feature is enabled.
- Following are the requirements for **Strong Password**:
- The password can have minimum 8 characters; maximum 14 characters.
  - The password must not contain the user's name.
  - The password must contain characters from three of the following four categories:
    - English uppercase letters (A through Z)
    - English lowercase letters (a through z)
    - Base 10 digits (0 through 9)
    - Non-alphabetic characters !, @, #, \$, %, ^, &, \*, -, \_, =, “
- Step 9** Continue with [Setting Up the System With the Cisco IMC Configuration Utility, on page 20](#).

---

## Setting Up the System With the Cisco IMC Configuration Utility

### Before you begin

The following procedure is performed after you connect to the system and open the Cisco IMC Configuration Utility.

- 
- Step 1** Set the NIC mode to choose which ports to use to access Cisco IMC for server management:
- *Dedicated* (default)—The dedicated management port is used to access Cisco IMC. You must select the *None* NIC redundancy setting in the following step.
  - *Cisco Card*—The ports on an installed Cisco UCS Virtual Interface Card (VIC) are used to access the Cisco IMC. You must select either the *Active-Active* or *Active-standby* NIC redundancy setting in the following step. See also the required VIC Slot setting below.
  - *VIC Slot*—Only if you use the Cisco Card NIC mode, you must select this setting to match where your VIC is installed. The choices are Riser1, Riser2, or MLOM.
    - For servers with PCIe Riser 1A and 1A combination:
      - If you select Riser1, you must install the VIC in slot 2.
      - If you select Riser2, you must install the VIC in slot 5.



- If you select MLOM, you must install an mLOM-style VIC in the mLOM slot.

**Step 2** Set the NIC redundancy to your preference. This server has three possible NIC redundancy settings:

- *None*—The ports operate independently and do not fail over if there is a problem. This setting can be used only with the Dedicated NIC mode.
- *Active-standby*—If an active port fails, traffic fails over to a standby port. Cisco Card modes can each use either Active-standby or Active-active settings.
- *Active-active* (default)—All ports are utilized simultaneously. Cisco Card modes can each use either Active-standby or Active-active settings.

**Step 3** Choose whether to enable DHCP for dynamic network settings, or to enter static network settings.

**Note** Before you enable DHCP, you must preconfigure your DHCP server with the range of MAC addresses for this server. The MAC address is printed on a label on the rear of the server. This server has a range of six MAC addresses assigned to Cisco IMC. The MAC address printed on the label is the beginning of the range of six contiguous MAC addresses.

The *static* IPv4 and IPv6 settings include the following:

- The Cisco IMC IP address.  
For IPv6, valid values are 1 - 127.
- The gateway.  
For IPv6, if you do not know the gateway, you can set it as none by entering :: (two colons).
- The preferred DNS server address.  
For IPv6, you can set this as none by entering :: (two colons).

**Step 4** (Optional) Make VLAN settings.

**Step 5** Press **F1** to go to the second settings window, then continue with the next step.

From the second window, you can press **F2** to switch back to the first window.

**Step 6** (Optional) Set a hostname for the server.

**Step 7** (Optional) Enable dynamic DNS and set a dynamic DNS (DDNS) domain.

**Step 8** (Optional) If you check the Factory Default check box, the server reverts to the factory defaults.

**Step 9** (Optional) Set a default user password.

**Note** The factory default username for the server is *admin*. The default password is *password*.

**Step 10** (Optional) Enable auto-negotiation of port settings or set the port speed and duplex mode manually.

**Note** Auto-negotiation is applicable only when you use the Dedicated NIC mode. Auto-negotiation sets the port speed and duplex mode automatically based on the switch port to which the server is connected. If you disable auto-negotiation, you must set the port speed and duplex mode manually.

**Step 11** (Optional) Reset port profiles and the port name.

**Step 12** Press **F5** to refresh the settings that you made. You might have to wait about 45 seconds until the new settings appear and the message, `Network settings configured` is displayed before you reboot the server in the next step.

**Step 13** Press **F10** to save your settings and reboot the server.

**Note** If you chose to enable DHCP, the dynamically assigned IP and MAC addresses are displayed on the console screen during bootup.

### What to do next

Use a browser and the IP address of the Cisco IMC to connect to the Cisco IMC management interface. The IP address is based upon the settings that you made (either a static address or the address assigned by your DHCP server).



**Note** The factory default username for the server is *admin*. The default password is *password*.

To manage the server, see the *Cisco UCS C-Series Rack-Mount Server Configuration Guide* or the *Cisco UCS C-Series Rack-Mount Server CLI Configuration Guide* for instructions on using those interfaces for your Cisco IMC release. The links to the configuration guides are in the [Configuration Guides](#).

## NIC Mode and NIC Redundancy Settings

**Table 2: Valid NIC Redundancy Settings For Each NIC Mode**

NIC Mode	Valid NIC Redundancy Settings
Dedicated	None
Cisco Card	Active-active Active-standby

This server has the following NIC mode settings that you can choose from:

- *Dedicated*—The dedicated management port is used to access Cisco IMC. You must select the *None* NIC redundancy setting in the following step.
- *Cisco Card*—The ports on an installed Cisco UCS Virtual Interface Card (VIC) are used to access the Cisco IMC. You must select either the *Active-Active* or *Active-standby* NIC redundancy setting in the following step.

See also the required VIC Slot setting below.

- *VIC Slot*—Only if you use the Cisco Card NIC mode, you must select this setting to match where your VIC is installed. The choices are Riser1, Riser2, or Flex-LOM (the mLOM slot).
  - For servers with PCIe Riser 1A and 1A combination:
    - If you select Riser1, you must install the VIC in slot 2.
    - If you select Riser2, you must install the VIC in slot 5.

- If you select MLOM, you must install an mLOM-style VIC in the mLOM slot.

This server has the following NIC redundancy settings that you can choose from:

- *None*—The ports operate independently and do not fail over if there is a problem. This setting can be used only with the Dedicated NIC mode.
- *Active-standby*—If an active port fails, traffic fails over to a standby port. Cisco Card modes can each use either Active-standby or Active-active settings.
- *Active-active* (default)—All ports are utilized simultaneously. Cisco Card modes can each use either Active-standby or Active-active settings.

## Updating the BIOS and Cisco IMC Firmware



### Caution

When you upgrade the BIOS firmware, you must also upgrade the Cisco IMC firmware to the same version or the server does not boot. Do not power off the server until the BIOS and Cisco IMC firmware are matching or the server does not boot.

Cisco provides the *Cisco Host Upgrade Utility* to assist with simultaneously upgrading the BIOS, Cisco IMC, and other firmware to compatible levels.

The server uses firmware obtained from and certified by Cisco. Cisco provides release notes with each firmware image. There are several possible methods for updating the firmware:

- **Recommended method for firmware update:** Use the Cisco Host Upgrade Utility to simultaneously upgrade the Cisco IMC, BIOS, and component firmware to compatible levels.

See the *Cisco Host Upgrade Utility Quick Reference Guide* for your firmware release at the documentation roadmap link below.

- You can upgrade the Cisco IMC and BIOS firmware by using the Cisco IMC GUI interface.  
See the *Cisco UCS C-Series Rack-Mount Server Configuration Guide*.
- You can upgrade the Cisco IMC and BIOS firmware by using the Cisco IMC CLI interface.  
See the *Cisco UCS C-Series Rack-Mount Server CLI Configuration Guide*.

For links to the documents listed above, see the [Cisco UCS C-Series Documentation Roadmap](#).

## Accessing the System BIOS

**Step 1** Enter the BIOS Setup Utility by pressing the **F2** key when prompted during bootup.

**Note** The version and build of the current BIOS are displayed on the Main page of the utility.

**Step 2** Use the arrow keys to select the BIOS menu page.

**Step 3** Highlight the field to be modified by using the arrow keys.

- Step 4** Press **Enter** to select the field that you want to change, and then modify the value in the field.
- Step 5** Press the right arrow key until the Exit menu screen is displayed.
- Step 6** Follow the instructions on the Exit menu screen to save your changes and exit the setup utility (or press **F10**). You can exit without saving changes by pressing **Esc**.
- 

## Smart Access Serial

This server supports the Smart Access Serial feature. This feature allows you to switch between host serial and Cisco IMC CLI.

- This feature has the following requirements:
  - A serial cable connection, which can use the RJ-45 serial connector on the server front panel.
  - Console redirection must be enabled in the server BIOS.
  - Terminal type must be set to VT100+ or VTUFT8.
  - Serial-over-LAN (SOL) must be disabled (SOL is disabled by default).
- To switch from host serial to Cisco IMC CLI, press **Esc+9**.  
You must enter your Cisco IMC credentials to authenticate the connection.
- To switch from Cisco IMC CLI to host serial, press **Esc+8**.



---

**Note** You cannot switch to Cisco IMC CLI if the serial-over-LAN (SOL) feature is enabled.

---

- After a session is created, it is shown in the CLI or web GUI by the name `serial`.

## Smart Access USB

This server supports the Smart Access USB feature. The board management controller (BMC) in this server can accept a USB mass storage device and access the data on it. This feature allows you to use the front-panel USB device as a medium to transfer data between the BMC and the user without need for network connectivity. This can be useful, for example, when remote BMC interfaces are not yet available, or are not accessible due to network misconfiguration.

- This feature has the following requirements:
  - Connect a USB keyboard and mouse, and VGA monitor to the corresponding connectors on the front panel.
  - A USB storage device connected to one of the USB 3.0 connectors on the front panel.
  - You can use USB 3.0-based devices, but they will operate at USB 2.0 speed.
  - We recommend that the USB device have only one partition.

- The file system formats supported are: FAT16, FAT32, MSDOS, EXT2, EXT3, and EXT4. NTFS is not supported.
- Smart Access USB can be enabled or disabled using any of the BMC user interfaces. For example, you can use the Cisco IMC Configuration Utility that is accessed by pressing **F8** when prompted during bootup.
  - Enabled: the front-panel USB device is connected to the BMC.
  - Disabled: the front-panel USB device is connected to the host.
- In a case where no management network is available to connect remotely to Cisco IMC, a Device Firmware Update (DFU) shell over serial cable can be used to generate and download technical support files to the USB device that is attached to front panel USB port.





## CHAPTER 3

# Maintaining the Server

---

- [Status LEDs and Buttons, on page 28](#)
- [Preparing For Component Installation, on page 34](#)
- [Hot Swap vs Hot Plug, on page 37](#)
- [Removing and Replacing Components, on page 38](#)
- [Replacing Front-Loading SAS/SATA Drives, on page 40](#)
- [4K Sector Format SAS/SATA Drives Considerations, on page 41](#)
- [Replacing Front-Loading NVMe SSDs, on page 43](#)
- [Replacing Rear-Loading NVMe SSDs, on page 46](#)
- [Replacing Fan Modules, on page 49](#)
- [Replacing CPUs and Heatsinks, on page 51](#)
- [Replacing Memory DIMMs, on page 59](#)
- [Replacing a Mini-Storage Module, on page 67](#)
- [Replacing a USB Drive, on page 69](#)
- [Replacing the RTC Battery, on page 71](#)
- [Replacing Power Supplies, on page 72](#)
- [Replacing a PCIe Riser, on page 77](#)
- [Replacing NVMe Cable, on page 78](#)
- [Replacing a PCIe Card, on page 86](#)
- [Replacing an mLOM Card, on page 92](#)
- [Replacing a SAS Storage Controller Card \(RAID or HBA\), on page 92](#)
- [Replacing the Supercap \(RAID Backup\), on page 95](#)
- [Replacing a Boot-Optimized M.2 RAID Controller Module, on page 96](#)
- [Replacing a Chassis Intrusion Switch, on page 99](#)
- [Installing a Trusted Platform Module \(TPM\), on page 101](#)
- [Removing the PCB Assembly \(PCBA\), on page 103](#)
- [Service Headers and Jumpers, on page 105](#)

# Status LEDs and Buttons

## Front-Panel LEDs

Figure 9: Front Panel LEDs

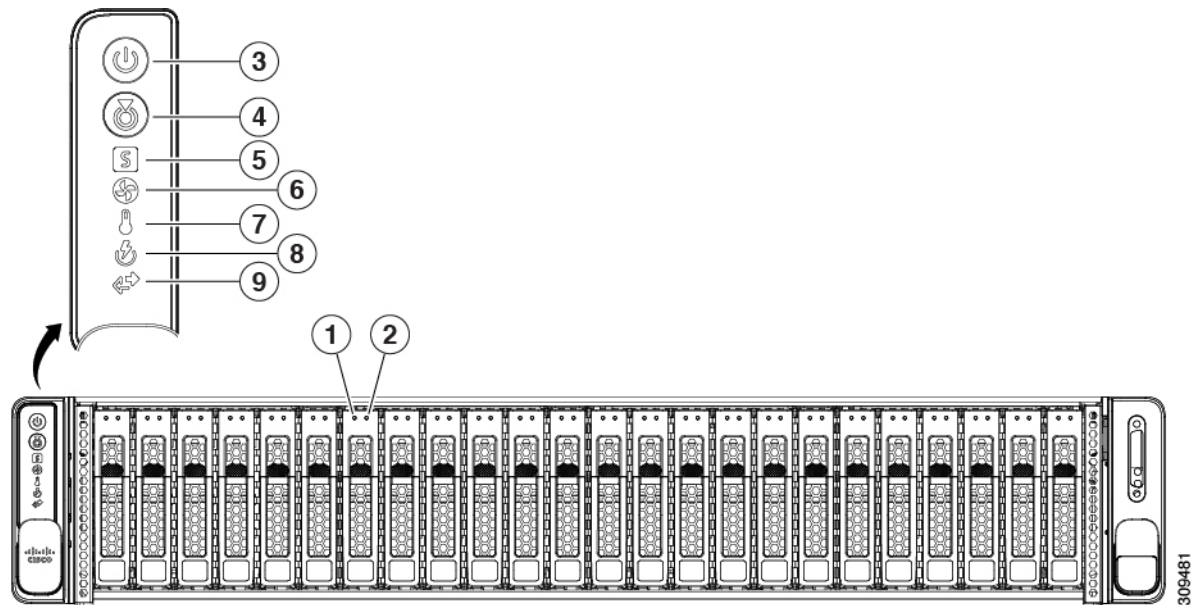


Table 3: Front Panel LEDs, Definition of States

	LED Name	States
1 SAS	SAS/SATA drive fault  <b>Note</b> NVMe solid state drive (SSD) drive tray LEDs have different behavior than SAS/SATA drive trays.	<ul style="list-style-type: none"> <li>• Off—The hard drive is operating properly.</li> <li>• Amber—Drive fault detected.</li> <li>• Amber, blinking—The device is rebuilding.</li> <li>• Amber, blinking with one-second interval—Drive locate function activated in the software.</li> </ul>
2 SAS	SAS/SATA drive activity LED	<ul style="list-style-type: none"> <li>• Off—There is no hard drive in the hard drive tray (no access, no fault).</li> <li>• Green—The hard drive is ready.</li> <li>• Green, blinking—The hard drive is reading or writing data.</li> </ul>



<b>1</b>  <b>NVMe</b>	<b>Note</b> NVMe solid state drive (SSD) drive tray LEDs have different behavior than SAS/SATA drive trays.	<ul style="list-style-type: none"> <li>• Off—The drive is not in use and can be safely removed.</li> <li>• Green—The drive is in use and functioning properly.</li> <li>• Green, blinking—the driver is initializing following insertion or the driver is unloading following an eject command.</li> <li>• Amber—The drive has failed.</li> <li>• Amber, blinking—A drive Locate command has been issued in the software.</li> </ul>
<b>2</b>  <b>NVMe</b>	NVMe SSD activity	<ul style="list-style-type: none"> <li>• Off—No drive activity.</li> <li>• Green, blinking—There is drive activity.</li> </ul>
<b>3</b>	Power button/LED	<ul style="list-style-type: none"> <li>• Off—There is no AC power to the server.</li> <li>• Amber—The server is in standby power mode. Power is supplied only to the Cisco IMC and some motherboard functions.</li> <li>• Green—The server is in main power mode. Power is supplied to all server components.</li> </ul>
<b>4</b>	Unit identification	<ul style="list-style-type: none"> <li>• Off—The unit identification function is not in use.</li> <li>• Blue, blinking—The unit identification function is activated.</li> </ul>

5	System health	<ul style="list-style-type: none"> <li>• Green—The server is running in normal operating condition.</li> <li>• Green, blinking—The server is performing system initialization and memory check.</li> <li>• Amber, steady—The server is in a degraded operational state (minor fault). For example: <ul style="list-style-type: none"> <li>• Power supply redundancy is lost.</li> <li>• CPUs are mismatched.</li> <li>• At least one CPU is faulty.</li> <li>• At least one DIMM is faulty.</li> <li>• At least one drive in a RAID configuration failed.</li> </ul> </li> <li>• Amber, 2 blinks—There is a major fault with the system board.</li> <li>• Amber, 3 blinks—There is a major fault with the memory DIMMs.</li> <li>• Amber, 4 blinks—There is a major fault with the CPUs.</li> </ul>
6	Fan status	<ul style="list-style-type: none"> <li>• Green—All fan modules are operating properly.</li> <li>• Amber, blinking—One or more fan modules breached the non-recoverable threshold.</li> </ul>
7	Temperature status	<ul style="list-style-type: none"> <li>• Green—The server is operating at normal temperature.</li> <li>• Amber, steady—One or more temperature sensors breached the critical threshold.</li> <li>• Amber, blinking—One or more temperature sensors breached the non-recoverable threshold.</li> </ul>
8	Power supply status	<ul style="list-style-type: none"> <li>• Green—All power supplies are operating normally.</li> <li>• Amber, steady—One or more power supplies are in a degraded operational state.</li> <li>• Amber, blinking—One or more power supplies are in a critical fault state.</li> </ul>
9	Network link activity	<ul style="list-style-type: none"> <li>• Off—Cisco MLOM/VIC and BMC port link is idle.</li> <li>• Green—One or more Cisco MLOM/VIC and BMC port link are active, but there is no activity.</li> <li>• Green, blinking—One or more Cisco MLOM/VIC and BMC port link are active, with activity.</li> </ul>

# Rear-Panel LEDs

Figure 10: Rear Panel LEDs

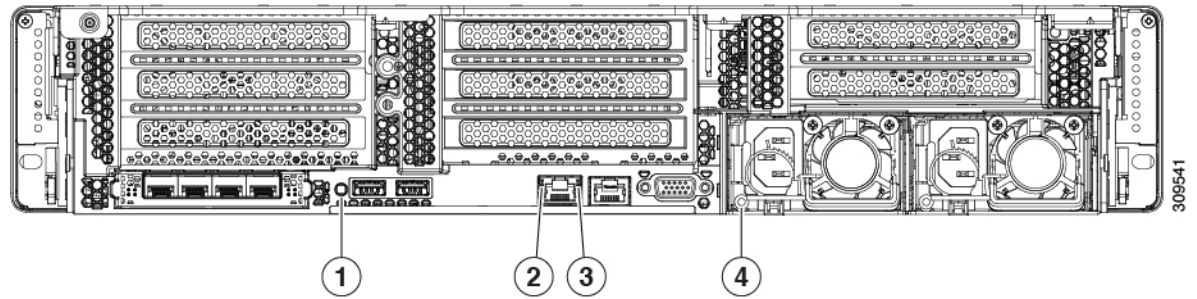


Table 4: Rear Panel LEDs, Definition of States

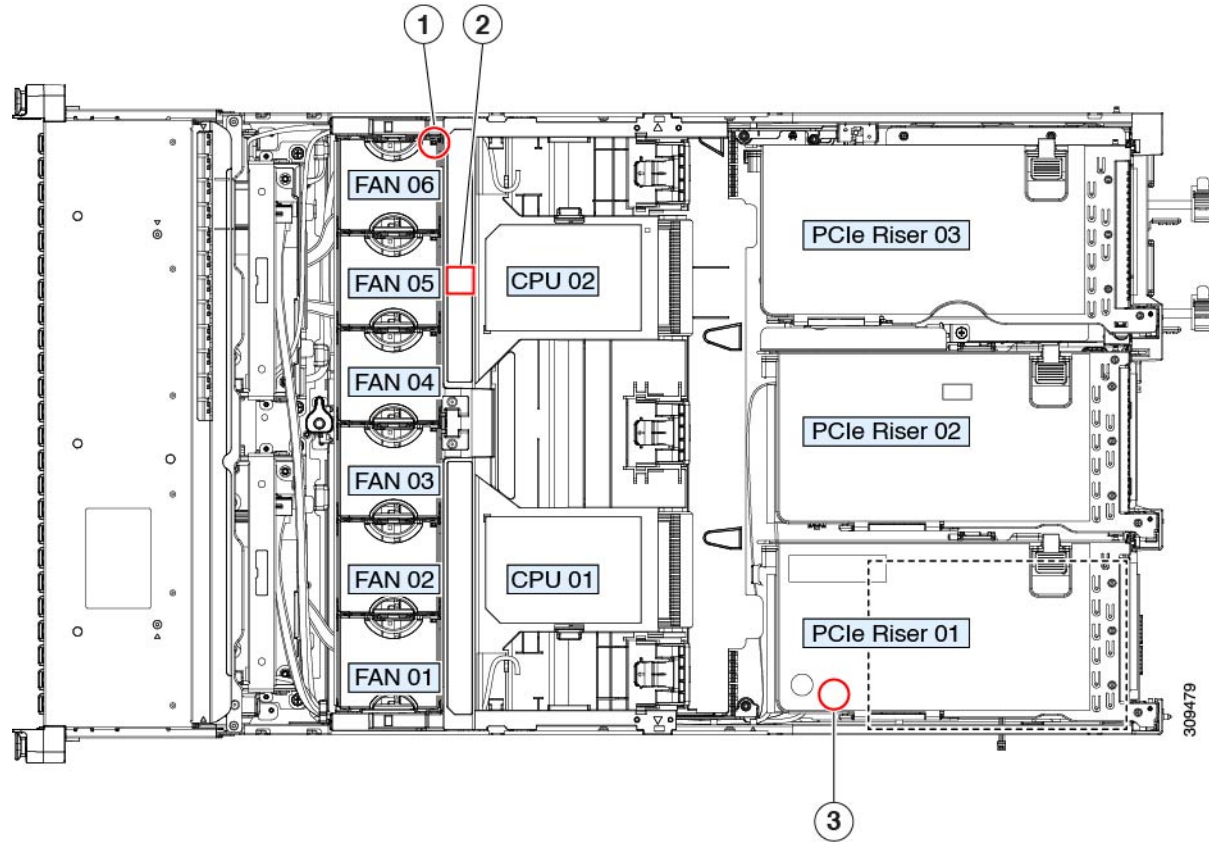
	LED Name	States
1	Unit Identification LED	<ul style="list-style-type: none"> <li>• Off—The unit identification function is not in use.</li> <li>• Blue, blinking—The unit identification function is activated.</li> </ul>
2	1-Gb Ethernet dedicated management link speed	<ul style="list-style-type: none"> <li>• Off—Link speed is 10 Mbps.</li> <li>• Amber—Link speed is 100 Mbps.</li> <li>• Green—Link speed is 1 Gbps.</li> </ul>
3	1-Gb Ethernet dedicated management link status	<ul style="list-style-type: none"> <li>• Off—No link is present.</li> <li>• Green—Link is active.</li> <li>• Green, blinking—Traffic is present on the active link.</li> </ul>

4	Power supply status (one LED each power supply unit)	<p><b>AC power supplies:</b></p> <ul style="list-style-type: none"> <li>• Off—No AC input (12 V main power off, 12 V standby power off).</li> <li>• Green, blinking—12 V main power off; 12 V standby power on.</li> <li>• Green, solid—12 V main power on; 12 V standby power on.</li> <li>• Amber, blinking—Warning threshold detected but 12 V main power on.</li> <li>• Amber, solid—Critical error detected; 12 V main power off (for example, over-current, over-voltage, or over-temperature failure).</li> </ul> <p><b>DC power supply (UCSC-PSUV2-1050DC):</b></p> <ul style="list-style-type: none"> <li>• Off—No DC input (12 V main power off, 12 V standby power off).</li> <li>• Green, blinking—12 V main power off; 12 V standby power on.</li> <li>• Green, solid—12 V main power on; 12 V standby power on.</li> <li>• Amber, blinking—Warning threshold detected but 12 V main power on.</li> <li>• Amber, solid—Critical error detected; 12 V main power off (for example, over-current, over-voltage, or over-temperature failure).</li> </ul>
---	--	---

## Internal Diagnostic LEDs

The server has internal fault LEDs for CPUs, DIMMs, and fan modules.

Figure 11: Internal Diagnostic LED Locations



<p><b>1</b></p>	<p>Fan module fault LEDs (one on the top of each fan module)</p> <ul style="list-style-type: none"> <li>• Amber—Fan has a fault or is not fully seated.</li> <li>• Green—Fan is OK.</li> </ul>	<p><b>2</b></p>	<p>DIMM fault LEDs (one behind each DIMM socket on the motherboard)</p> <p>These LEDs operate only when the server is in standby power mode.</p> <ul style="list-style-type: none"> <li>• Amber—DIMM has a fault.</li> <li>• Off—DIMM is OK.</li> </ul>
<p><b>2</b></p>	<p>CPU fault LEDs</p> <p>These LEDs operate only when the server is in standby power mode.</p> <ul style="list-style-type: none"> <li>• Amber—CPU has a fault.</li> <li>• Off—CPU is OK.</li> </ul>	<p>-</p>	

# Preparing For Component Installation

## Required Equipment For Service Procedures

The following tools and equipment are used to perform the procedures in this chapter:

- T-20 Torx driver (supplied with replacement CPUs for heatsink removal)
- #1 Phillips-head screwdriver for M.2 SSD replacement.
- #2 Phillips-head screwdriver for PCIe riser/PCIe card replacement.
- ¼-inch (or equivalent) flat-head screwdriver (for TPM installation)
- Electrostatic discharge (ESD) strap or other grounding equipment such as a grounded mat

## Shutting Down and Removing Power From the Server

The server can run in either of two power modes:

- Main power mode—Power is supplied to all server components and any operating system on your drives can run.
- Standby power mode—Power is supplied only to the service processor and certain components. It is safe for the operating system and data to remove power cords from the server in this mode.



---

**Caution**

After a server is shut down to standby power, electric current is still present in the server. To completely remove power, you must disconnect all power cords from the power supplies in the server, as directed in the service procedures.

You can shut down the server by using the front-panel power button or the software management interfaces.

---

## Shutting Down Using the Power Button

---

**Step 1** Check the color of the Power button/LED:

- Amber—The server is already in standby mode and you can safely remove power.
- Green—The server is in main power mode and must be shut down before you can safely remove power.

**Step 2** Invoke either a graceful shutdown or a hard shutdown:

**Caution** To avoid data loss or damage to your operating system, you should always invoke a graceful shutdown of the operating system.

- Graceful shutdown—Press and release the **Power** button. The operating system performs a graceful shutdown and the server goes to standby mode, which is indicated by an amber Power button/LED.

- Emergency shutdown—Press and hold the **Power** button for 4 seconds to force the main power off and immediately enter standby mode.

**Step 3** If a service procedure instructs you to completely remove power from the server, disconnect all power cords from the power supplies in the server.

---

## Shutting Down Using The Cisco IMC GUI

You must log in with user or admin privileges to perform this task.

---

**Step 1** In the Navigation pane, click the **Server** tab.

**Step 2** On the Server tab, click **Summary**.

**Step 3** In the Actions area, click **Power Off Server**.

**Step 4** Click **OK**.

The operating system performs a graceful shutdown and the server goes to standby mode, which is indicated by an amber Power button/LED.

**Step 5** If a service procedure instructs you to completely remove power from the server, disconnect all power cords from the power supplies in the server.

---

## Shutting Down Using The Cisco IMC CLI

You must log in with user or admin privileges to perform this task.

---

**Step 1** At the server prompt, enter:

**Example:**

```
server# scope chassis
```

**Step 2** At the chassis prompt, enter:

**Example:**

```
server/chassis# power shutdown
```

The operating system performs a graceful shutdown and the server goes to standby mode, which is indicated by an amber Power button/LED.

**Step 3** If a service procedure instructs you to completely remove power from the server, disconnect all power cords from the power supplies in the server.

---

## Removing the Server Top Cover

**Step 1** Remove the top cover:

- a) If the cover latch is locked, slide the lock sideways to unlock it.  
When the latch is unlocked, the handle pops up so that you can grasp it.
- b) Lift on the end of the latch so that it pivots vertically to 90 degrees.
- c) Simultaneously, slide the cover back and lift the top cover straight up from the server and set it aside.

**Step 2**

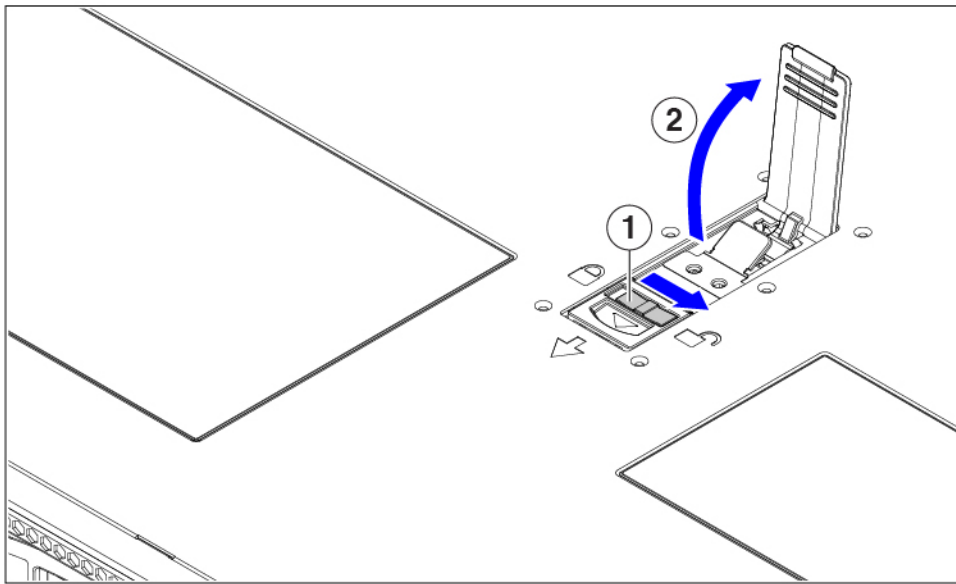
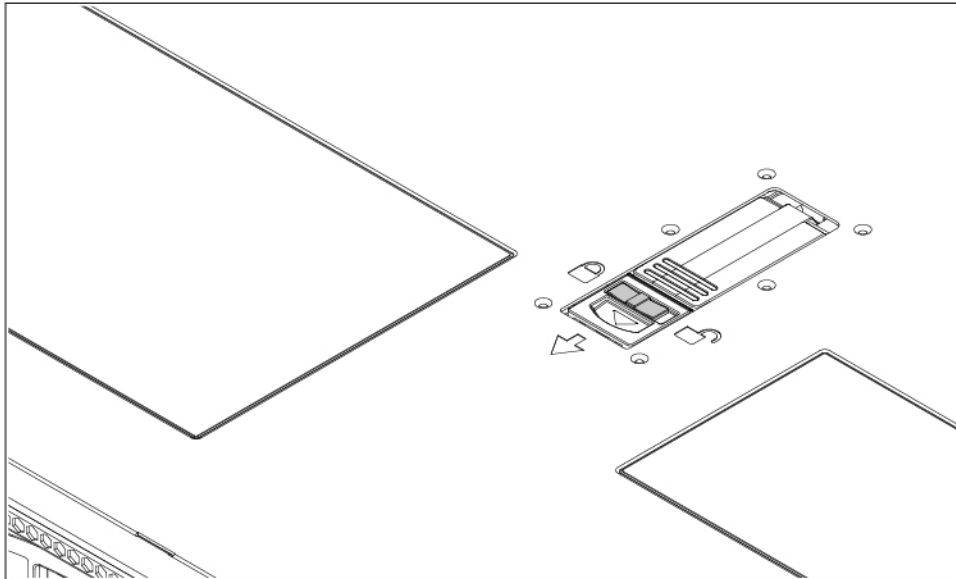
Replace the top cover:

- a) With the latch in the fully open position, place the cover on top of the server about one-half inch (1.27 cm) behind the lip of the front cover panel.
- b) Slide the cover forward until the latch makes contact.
- c) Press the latch down to the closed position. The cover is pushed forward to the closed position as you push down the latch.
- d) Lock the latch by sliding the lock button to sideways to the left.

Locking the latch ensures that the server latch handle does not protrude when you install the blade.



Figure 12: Removing the Top Cover



309157

1	Cover lock	2	Cover latch handle
---	------------	---	--------------------

## Hot Swap vs Hot Plug

Some components can be removed and replaced without shutting down and removing power from the server. This type of replacement has two varieties: hot-swap and hot-plug.

- Hot-swap replacement—You do not have to shut down the component in the software or operating system. This applies to the following components:
  - SAS/SATA hard drives
  - SAS/SATA solid state drives
  - Cooling fan modules
  - Power supplies (when redundant as 1+1)
- Hot-plug replacement—You must take the component offline before removing it for the following component:
  - NVMe PCIe solid state drives

## Removing and Replacing Components



**Warning** Blank faceplates and cover panels serve three important functions: they prevent exposure to hazardous voltages and currents inside the chassis; they contain electromagnetic interference (EMI) that might disrupt other equipment; and they direct the flow of cooling air through the chassis. Do not operate the system unless all cards, faceplates, front covers, and rear covers are in place.

Statement 1029



**Caution** When handling server components, handle them only by carrier edges and use an electrostatic discharge (ESD) wrist-strap or other grounding device to avoid damage.

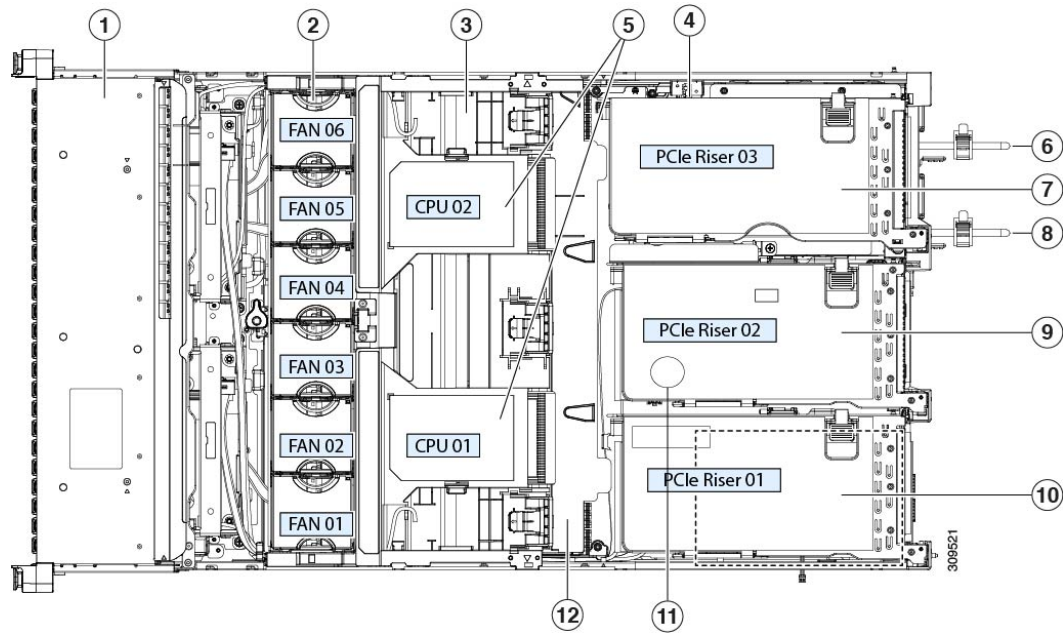


**Tip** You can press the unit identification button on the front panel or rear panel to turn on a flashing, blue unit identification LED on both the front and rear panels of the server. This button allows you to locate the specific server that you are servicing when you go to the opposite side of the rack. You can also activate these LEDs remotely by using the Cisco IMC interface.

## Component Location

This topic shows the locations of the field-replaceable components and service-related items. The view in the following figure shows the server with the top cover removed.

Figure 13: Cisco UCS C245 M6 Server Serviceable Component Locations



1	Front-loading drive bays.	2	Cooling fan modules (six, hot-swappable) Power supplies (hot-swappable when redundant as 1+1)
3	DIMM sockets on motherboard (16 per CPU) See <b>DIMM Population Rules and Memory Performance Guidelines</b> for DIMM slot numbering.  <b>Note</b> An air baffle rests on top of the DIMM and CPUs when the server is operating. The air baffle is not displayed in this illustration.	4	Intrusion switch
5	CPU sockets, 2 CPU sockets are arranged side by side and labeled CPU1 and CPU2 next to the CPU socket.	6	Power Supply Unit (PSU) 1

7	<p>Riser 3—Supports Riser 3A, 3B and 3C. PCIe slots 7 and 8 numbered bottom to top with the following options:</p> <ul style="list-style-type: none"> <li>• Riser 3A—Slot 7 PCIe supports full height, full length PCIe Add-in-card; Slot 8 PCIe supports full height, full length PCIe Add-in-card.</li> <li>• Riser 3B—Slot 7 supports 2.5-inch NVMe SSD; Slot 8 supports 2.5-inch NVMe SSD.</li> <li>• Riser 3C—Slot 7 PCIe supports full height, full length PCIe Add-in-card.</li> </ul>	8	Power Supply Unit (PSU) 2
9	<p>Riser 2—Supports Riser 2A. PCIe slots 4, 5, and 6 numbered bottom to top with the following option:</p> <ul style="list-style-type: none"> <li>• Riser 2A—Slot 4, 5, and 6 PCIe support full height, full length PCIe Add-in-card.</li> </ul>	10	<p>Riser 1—Supports Riser 1A and 1B. PCIe slots 1, 2, and 3 numbered bottom to top with the following options:</p> <ul style="list-style-type: none"> <li>• Riser 1A—Slot 1 PCIe supports full height, full length PCIe Add-in-card; Slot 2 PCIe supports full height, full length PCIe Add-in-card; Slot 3 PCIe supports full height, full length PCIe Add-in-card.</li> <li>• Riser 1B (Storage Option)—Slot 1 PCIe is disabled; Slot 2 supports 2.5-inch NVMe SSD; Slot 3 supports 2.5-inch NVMe SSD.</li> </ul>
11	RTC Battery	12	Internal USB Port

## Replacing Front-Loading SAS/SATA Drives



**Note** You do not have to shut down the server or drive to replace SAS/SATA hard drives or SSDs because they are hot-swappable.

### Front-Loading SAS/SATA Drive Population Guidelines

Cisco UCS C245 M6 Server (UCSC-C245-M6SX) is orderable in one Small form-factor (SFF) drives version, with 24-drive back-plane front panel configuration:

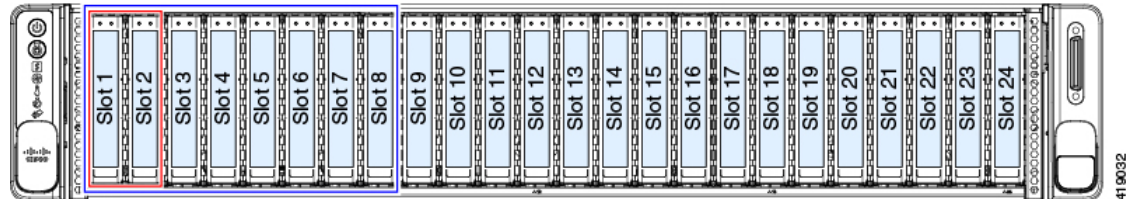
- Front-loading drive bays 1—24 support 2.5-inch SAS/SATA drives.



**Note** Optionally, front-loading drive bays 1 to 4 support 2.5-inch NVMe SSDs (with optional front NVMe cables).

Drive bay numbering is shown in the following figures.

**Figure 14: Small Form-Factor Drive Bay Numbering**



Observe these drive population guidelines for optimum performance:

- When populating drives, add drives to the lowest-numbered bays first.



**Note** For diagrams of which drive bays are controlled by particular controller cables on the backplane, see [Storage Controller Cable Connectors and Backplanes](#), on page 137.

- Keep an empty drive blanking tray in any unused bays to ensure proper airflow.
- You can mix SAS/SATA hard drives and SAS/SATA SSDs in the same server. However, you cannot configure a logical volume (virtual drive) that contains a mix of hard drives and SSDs. That is, when you create a logical volume, it must contain all SAS/SATA hard drives or all SAS/SATA SSDs.

## 4K Sector Format SAS/SATA Drives Considerations

- You must boot 4K sector format drives in UEFI mode, not legacy mode. See the procedures in this section.
- Do not configure 4K sector format and 512-byte sector format drives as part of the same RAID volume.
- For operating system support on 4K sector drives, see the interoperability matrix tool for your server: [Hardware and Software Interoperability Matrix Tools](#)

## Setting Up UEFI Mode Booting in the BIOS Setup Utility

- Step 1** Enter the BIOS setup utility by pressing the **F2** key when prompted during bootup.
- Step 2** Go to the **Boot Options** tab.
- Step 3** Set **UEFI Boot Options** to **Enabled**.
- Step 4** Under **Boot Option Priorities**, set your OS installation media (such as a virtual DVD) as your **Boot Option #1**.
- Step 5** Go to the **Advanced** tab.

- Step 6** Select **LOM** and **PCIe Slot Configuration**.
- Step 7** Set the **PCIe Slot ID: HBA Option ROM** to **UEFI Only**.
- Step 8** Press **F10** to save changes and exit the BIOS setup utility. Allow the server to reboot.
- Step 9** After the OS installs, verify the installation:
- Enter the BIOS setup utility by pressing the **F2** key when prompted during bootup.
  - Go to the Boot Options tab.
  - Under **Boot Option Priorities**, verify that the OS you installed is listed as your **Boot Option #1**.

---

## Setting Up UEFI Mode Booting in the Cisco IMC GUI

- Step 1** Use a web browser and the IP address of the server to log into the Cisco IMC GUI management interface.
- Step 2** Navigate to **Server > BIOS**.
- Step 3** Under Actions, click **Configure BIOS**.
- Step 4** In the Configure BIOS Parameters dialog, select the **Advanced** tab.
- Step 5** Go to the **LOM** and **PCIe Slot Configuration** section.
- Step 6** Set the **PCIe Slot: HBA Option ROM** to **UEFI Only**.
- Step 7** Click **Save Changes**. The dialog closes.
- Step 8** Under BIOS Properties, set **Configured Boot Order** to **UEFI**.
- Step 9** Under Actions, click **Configure Boot Order**.
- Step 10** In the Configure Boot Order dialog, click **Add Local HDD**.
- Step 11** In the Add Local HDD dialog, enter the information for the 4K sector format drive and make it first in the boot order.
- Step 12** Save changes and reboot the server. The changes you made will be visible after the system reboots.

---

## Replacing a Front-Loading SAS/SATA Drive



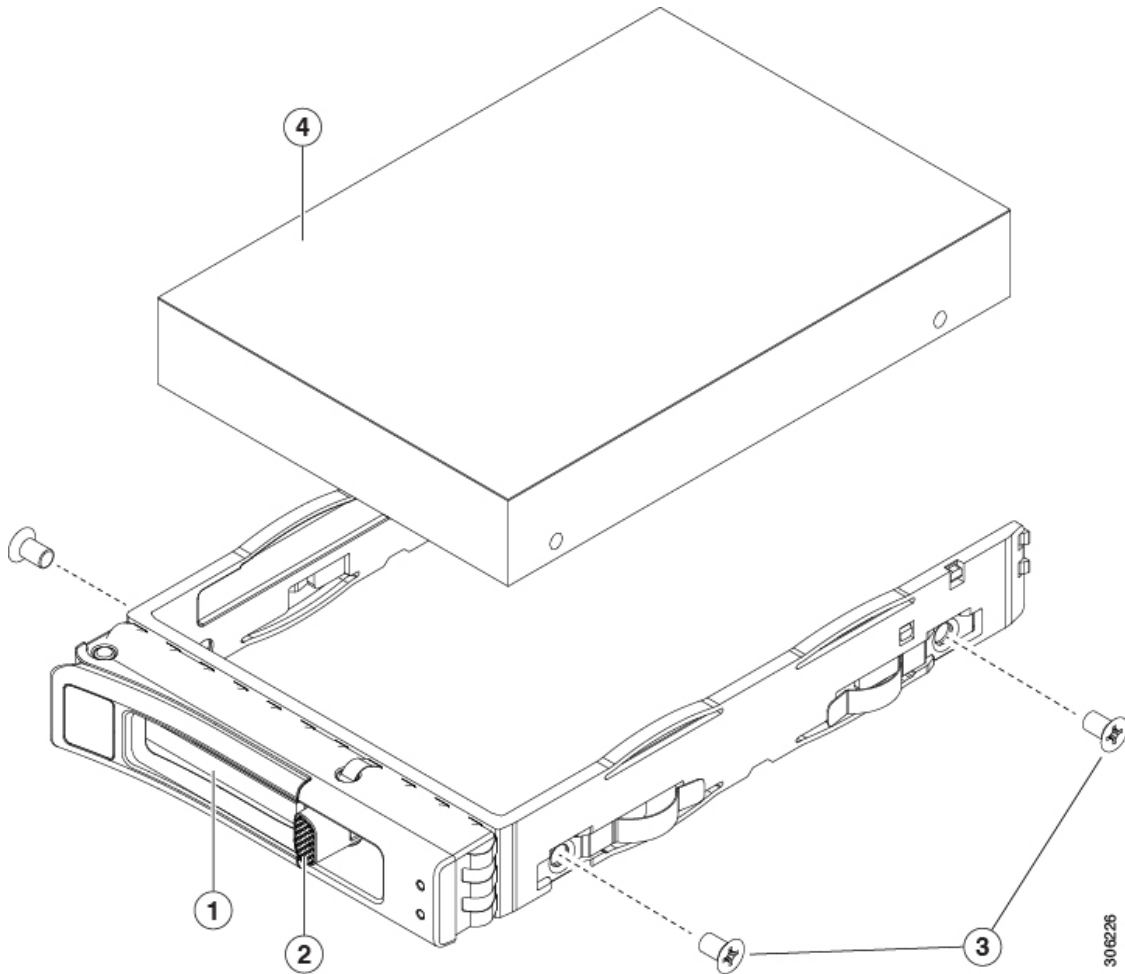
**Note** You do not have to shut down the server or drive to replace SAS/SATA hard drives or SSDs because they are hot-swappable.

Follow this procedure to remove a SAS/SATA drive from a vertical drive bay.

- Step 1** Remove the drive that you are replacing or remove a blank drive tray from the front of the server:
- Press the release button on the face of the drive tray.
  - Grasp and open the ejector lever and then pull the drive tray out of the slot.
  - If you are replacing an existing drive, remove the four drive-tray screws that secure the drive to the tray and then lift the drive out of the tray.
- Step 2** Install a new drive:
- Place a new drive in the empty drive tray and install the four drive-tray screws.

- b) With the ejector lever on the drive tray open, insert the drive tray into the empty drive bay.
- c) Push the tray into the slot until it touches the backplane, and then close the ejector lever to lock the drive in place.

**Figure 15: Replacing a Drive in a Drive Tray**



1	Ejector lever	3	Drive tray screws (two on each side)
2	Release button	4	Drive removed from drive tray

## Replacing Front-Loading NVMe SSDs

This section is for replacing 2.5-inch or 3.5-inch form-factor NVMe solid-state drives (SSDs) in front-panel drive bays.

## Front-Loading NVMe SSD Population Guidelines

Cisco UCS C245 M6 Server (UCSC-C245-M6SX) server supports 2.5 inch NVMe SSDs in the following front slots:

- Front-loading drive bays 1 to 4 support 2.5-inch NVMe SSDs (with optional front NVMe cables).

## Front-Loading NVMe SSD Requirements and Restrictions

Observe these requirements:

- The server must have two CPUs.
- Hot-plug support must be enabled in the system BIOS. If you ordered the system with NVMe drives, hot-plug support is enabled at the factory.

Observe these restrictions:

- NVMe 2.5 inch SSDs support booting only in UEFI mode. Legacy boot is not supported. For instructions on setting up UEFI boot, see [Setting Up UEFI Mode Booting in the BIOS Setup Utility, on page 41](#) or [Setting Up UEFI Mode Booting in the Cisco IMC GUI, on page 42](#).
- You cannot control NVMe PCIe SSDs with a SAS RAID controller because NVMe SSDs interface with the server via the NVMe connectors on the motherboard.
- You can combine NVMe 2.5 inch SSDs and HHHL form-factor SSDs in the same system, but the same partner brand must be used. For example, two *Intel* NVMe SFF 2.5-inch SSDs and two *HGST* HHHL form-factor SSDs is an invalid configuration. A valid configuration is two HGST NVMe SFF 2.5-inch SSDs and two HGST HHHL form-factor SSDs.
- UEFI boot is supported in all supported operating systems. Hot-insertion and hot-removal are supported in all supported operating systems except VMWare ESXi.

## Enabling Hot-Plug Support in the System BIOS

Hot-plug (OS-informed hot-insertion and hot-removal) is disabled in the system BIOS by default.

- If the system was ordered with NVMe PCIe SSDs, the setting was enabled at the factory. No action is required.
- If you are adding NVMe PCIe SSDs after-factory, you must enable hot-plug support in the BIOS. See the following procedures.

### Enabling Hot-Plug Support Using the BIOS Setup Utility

- 
- |               |  |
|---------------|--|
| <b>Step 1</b> | Enter the BIOS setup utility by pressing the <b>F2</b> key when prompted during bootup.  |
| <b>Step 2</b> | Navigate to <b>Advanced &gt; PCI Subsystem Settings &gt; NVMe SSD Hot-Plug Support</b> . |
| <b>Step 3</b> | Set the value to <b>Enabled</b> .  |
| <b>Step 4</b> | Save your changes and exit the utility.  |
-



## Enabling Hot-Plug Support Using the Cisco IMC GUI

- 
- Step 1** Use a browser to log in to the Cisco IMC GUI for the server.
- Step 2** Navigate to **Compute > BIOS > Advanced > PCI Configuration**.
- Step 3** Set NVME SSD Hot-Plug Support to **Enabled**.
- Step 4** Save your changes.
- 

## Replacing a Front-Loading NVMe SSD

This topic describes how to replace 2.5- or form-factor NVMe SSDs in the front-panel drive bays.



---

**Note** OS-surprise removal is not supported. OS-informed hot-insertion and hot-removal are supported on all supported operating systems except VMware ESXi.

---



---

**Note** OS-informed hot-insertion and hot-removal must be enabled in the system BIOS. See [Enabling Hot-Plug Support in the System BIOS, on page 44](#).

---

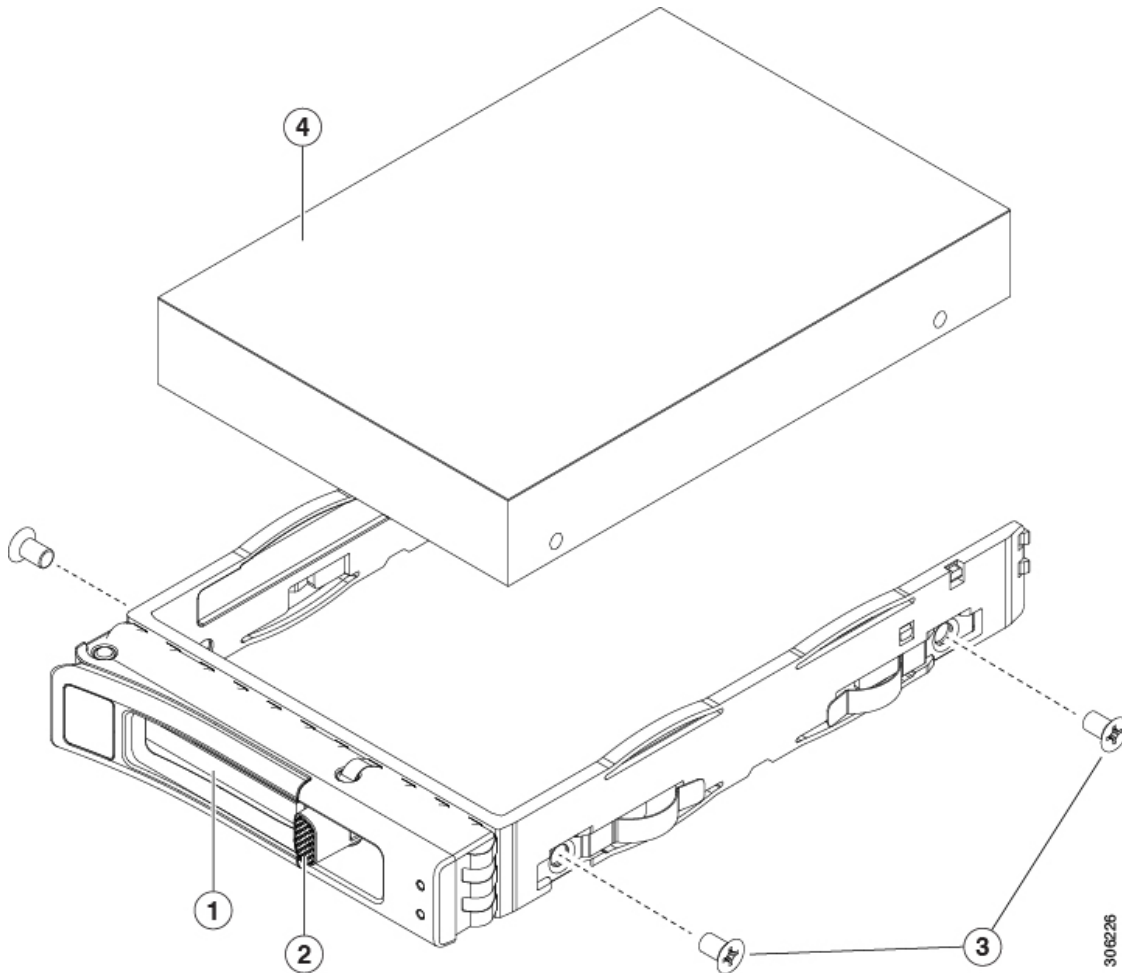
- 
- Step 1** Remove an existing front-loading NVMe SSD:
- Shut down the NVMe SSD to initiate an OS-informed removal. Use your operating system interface to shut down the drive, and then observe the drive-tray LED:
    - Green—The drive is in use and functioning properly. Do not remove.
    - Green, blinking—the driver is unloading following a shutdown command. Do not remove.
    - Off—The drive is not in use and can be safely removed.
  - Press the release button on the face of the drive tray.
  - Grasp and open the ejector lever and then pull the drive tray out of the slot.
  - Remove the four drive tray screws that secure the SSD to the tray and then lift the SSD out of the tray.

**Note** If this is the first time that front-loading NVMe SSDs are being installed in the server, you must install a PCIe cable with PCIe riser 2. See [Component Location, on page 6](#).

- Step 2** Install a new front-loading NVMe SSD:
- Place a new SSD in the empty drive tray and install the four drive-tray screws.
  - With the ejector lever on the drive tray open, insert the drive tray into the empty drive bay.
  - Push the tray into the slot until it touches the backplane, and then close the ejector lever to lock the drive in place.
- Step 3** Observe the drive-tray LED and wait until it returns to solid green before accessing the drive:
- Off—The drive is not in use.
  - Green, blinking—the driver is initializing following hot-plug insertion.

- Green—The drive is in use and functioning properly.

Figure 16: Replacing a Drive in a Drive Tray



1	Ejector lever	3	Drive tray screws (two on each side)
2	Release button	4	Drive removed from drive tray

## Replacing Rear-Loading NVMe SSDs

This section is for replacing 2.5-inch form-factor NVMe solid-state drives (SSDs) in rear-panel PCIe riser slots.

### Rear-Loading NVMe SSD Population Guidelines

Cisco UCS C245 M6 Server (UCSC-C245-M6SX) server supports NVMe SSDs in the following rear slots:

- Riser 1—Supports Riser 1A and 1B. PCIe slots 1, 2, and 3 numbered bottom to top with the following options:
  - Riser 1B (Storage Option)—Slot 1 PCIe is disabled; Slot 2 supports 2.5-inch NVMe SSD; Slot 3 supports 2.5-inch NVMe SSD.
- Riser 3—Supports Riser 3A, 3B and 3C. PCIe slots 7 and 8 numbered bottom to top with the following options:
  - Riser 3B—Slot 7 supports 2.5-inch NVMe SSD; Slot 8 supports 2.5-inch NVMe SSD.

## Rear-Loading NVMe SSD Requirements and Restrictions

Observe these requirements:

- The server must have two CPUs to support all four NVMe SSDs.
- PCIe riser 1B and 3B have connectors for the cable that connect to the front-panel drive controller.
- PCIe cable. This is the cable that carries the PCIe signal from the front-panel drive controller to PCIe riser 1B and 3B.
- Hot-plug support must be enabled in the system BIOS. If you ordered the system with NVMe drives, hot-plug support is enabled at the factory.

Observe these restrictions:

- NVMe SSDs support booting only in UEFI mode. Legacy boot is not supported. For instructions on setting up UEFI boot, see [Setting Up UEFI Mode Booting in the BIOS Setup Utility, on page 41](#) or [Setting Up UEFI Mode Booting in the Cisco IMC GUI, on page 42](#).
- You cannot control NVMe PCIe SSDs with a SAS RAID controller because NVMe SSDs interface with the server via the PCIe bus.
- You can combine NVMe 2.5-inch SSDs and HHHL form-factor SSDs in the same system, but the same partner brand must be used. For example, two *Intel* NVMe SFF 2.5-inch SSDs and two *HGST* HHHL form-factor SSDs is an invalid configuration. A valid configuration is two HGST NVMe SFF 2.5-inch SSDs and two HGST HHHL form-factor SSDs.
- UEFI boot is supported in all supported operating systems. Hot-insertion and hot-removal are supported in all supported operating systems except VMWare ESXi.

## Replacing a Rear-Loading NVMe SSD

This topic describes how to replace 2.5-inch form-factor NVMe SSDs in the rear-panel drive bays.



---

**Note** OS-surprise removal is not supported. OS-informed hot-insertion and hot-removal are supported on all supported operating systems except VMware ESXi.

---



---

**Note** OS-informed hot-insertion and hot-removal must be enabled in the system BIOS. See [Enabling Hot-Plug Support in the System BIOS, on page 44](#).

---

**Step 1** Remove an existing rear-loading NVMe SSD:

- a) Shut down the NVMe SSD to initiate an OS-informed removal. Use your operating system interface to shut down the drive, and then observe the drive-tray LED:
  - Green—The drive is in use and functioning properly. Do not remove.
  - Green, blinking—the driver is unloading following a shutdown command. Do not remove.
  - Off—The drive is not in use and can be safely removed.
- b) Press the release button on the face of the drive tray.
- c) Grasp and open the ejector lever and then pull the drive tray out of the slot.
- d) Remove the four drive tray screws that secure the SSD to the tray and then lift the SSD out of the tray.

**Note** If this is the first time that rear-loading NVMe SSDs are being installed in the server.

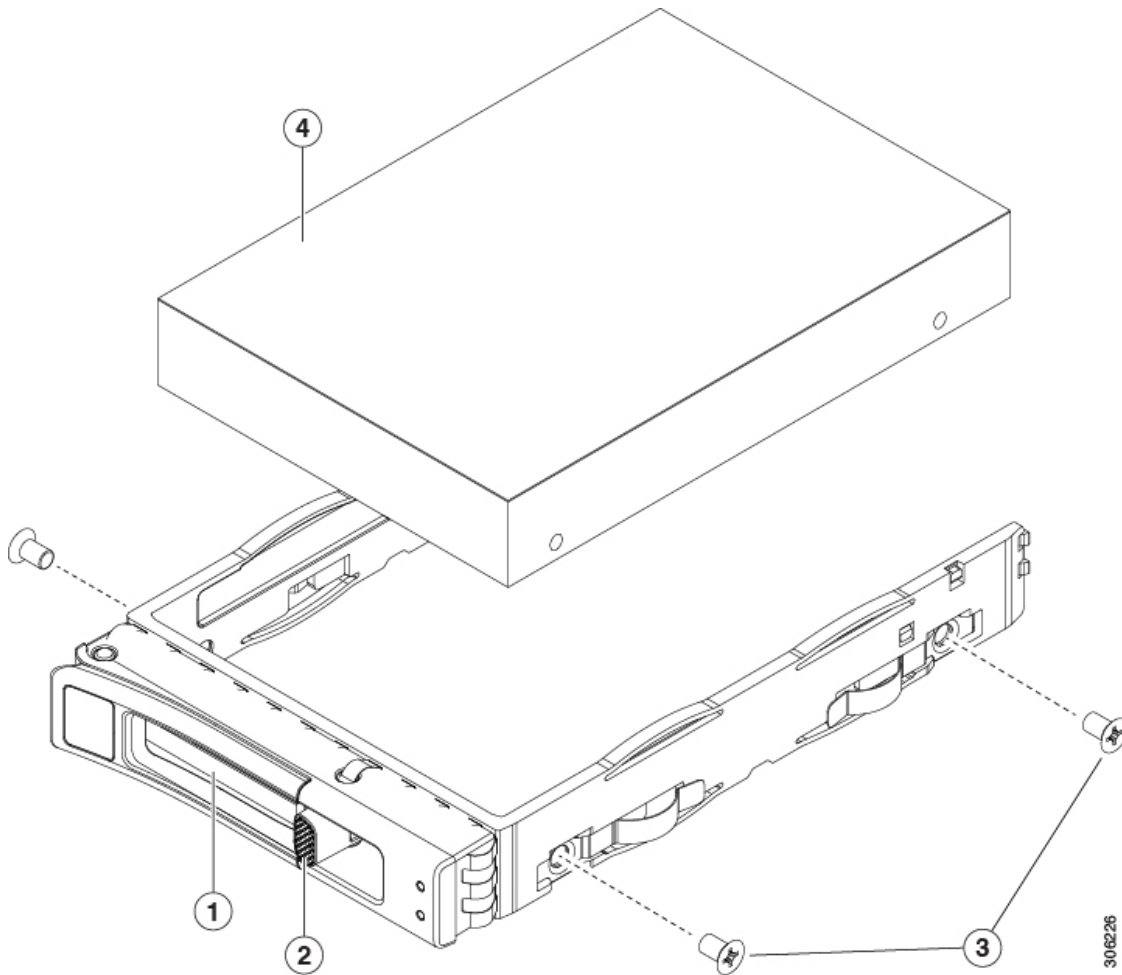
**Step 2** Install a new front-loading NVMe SSD:

- a) Place a new SSD in the empty drive tray and install the four drive-tray screws.
- b) With the ejector lever on the drive tray open, insert the drive tray into the empty drive bay.
- c) Push the tray into the slot until it touches the backplane, and then close the ejector lever to lock the drive in place.

**Step 3** Observe the drive-tray LED and wait until it returns to solid green before accessing the drive:

- Off—The drive is not in use.
- Green, blinking—the driver is initializing following hot-plug insertion.
- Green—The drive is in use and functioning properly.

Figure 17: Replacing a Drive in a Drive Tray



1	Ejector lever	3	Drive tray screws (two on each side)
2	Release button	4	Drive removed from drive tray

## Replacing Fan Modules

The six fan modules in the server are numbered as shown in [Component Location](#), on page 6.



**Tip** There is a fault LED on the top of each fan module. This LED lights green when the fan is correctly seated and is operating OK. The LED lights amber when the fan has a fault or is not correctly seated.



**Caution** You do not have to shut down or remove power from the server to replace fan modules because they are hot-swappable. However, to maintain proper cooling, do not operate the server for more than one minute with any fan module removed.

**Step 1** Remove an existing fan module:

- a) Slide the server out the front of the rack far enough so that you can remove the top cover. You might have to detach cables from the rear panel to provide clearance.

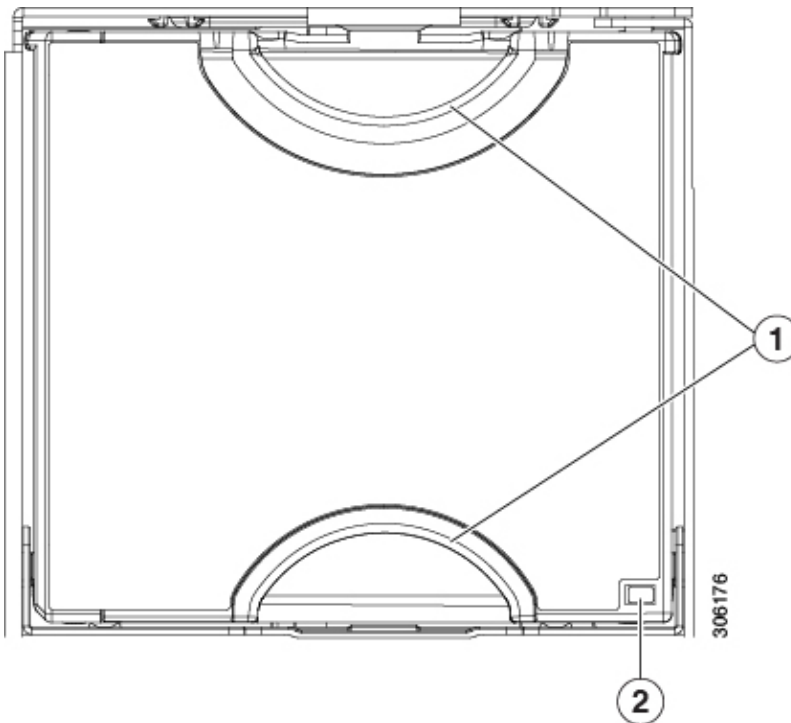
**Caution** If you cannot safely view and access the component, remove the server from the rack.

- b) Remove the top cover from the server as described in [Removing the Server Top Cover, on page 35](#).
- c) Grasp and squeeze the fan module release latches on its top. Lift straight up to disengage its connector from the motherboard.

**Step 2** Install a new fan module:

- a) Set the new fan module in place. The arrow printed on the top of the fan module should point toward the rear of the server.
- b) Press down gently on the fan module to fully engage it with the connector on the motherboard.
- c) Replace the top cover to the server.
- d) Replace the server in the rack, replace cables, and then fully power on the server by pressing the Power button.

**Figure 18: Top View of Fan Module**



<b>1</b>	Fan module release latches	<b>2</b>	Fan module fault LED
----------	----------------------------	----------	----------------------

# Replacing CPUs and Heatsinks

## CPU Configuration Rules

This server has two CPU sockets on the motherboard. Each CPU supports 8 DIMM channels (16 DIMM slots). See [DIMM Population Rules and Memory Performance Guidelines](#), on page 59.

- The server can operate with one CPU or two identical CPUs installed.
- The minimum configuration is that the server must have at least CPU 1 installed. Install CPU 1 first, and then CPU 2.
- The following restrictions apply when using a single-CPU configuration:
  - Any unused CPU socket must have the socket dust cover from the factory in place.
  - The maximum number of DIMMs is 16 (only CPU 1 channels A through H).

## Tools Required For CPU Replacement

You need the following tools and equipment for this procedure:

- T-20 Torx driver (for heatsink and CPU socket screws).
- Heatsink cleaning kit—Supplied with replacement CPU. Orderable separately as Cisco PID UCSX-HSCK=  
One cleaning kit can clean up to four CPUs.
- Thermal interface material (TIM)—Syringe supplied with replacement CPU. Use only if you are reusing your existing heatsink (new heatsinks have a pre-applied pad of TIM). Orderable separately as Cisco PID UCS-CPU-TIM=  
One TIM kit covers one CPU.

See also [Additional CPU-Related Parts to Order with RMA Replacement CPUs or RMA Nodes](#), on page 58.

## Replacing a CPU and Heatsink



### Caution

CPUs and their sockets are fragile and must be handled with extreme care to avoid damaging pins. The CPUs must be installed with heatsinks and thermal interface material to ensure cooling. Failure to install a CPU correctly might result in damage to the server.



**Caution** Always shut down the server before removing it from the chassis, as described in the procedures. Failure to shut down the server before removal results in the corresponding RAID supercap cache being discarded and other data might be lost.

**Step 1** Shut down the server by using the software interface or by pressing the server power button, as described in [Shutting Down and Removing Power From the Server, on page 34](#).

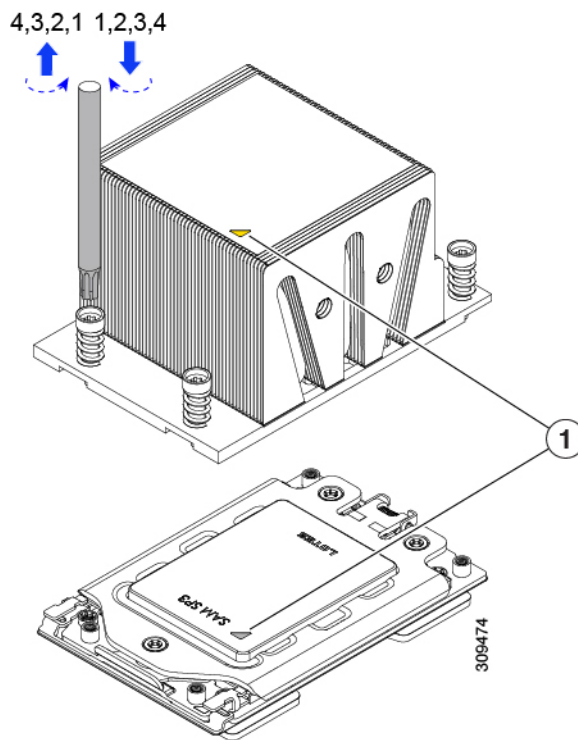
**Step 2** Disconnect any cables from ports on the server or installed cards.

**Step 3** Remove the heatsink from the CPU that you are replacing:

- a) Use a T-20 Torx driver to loosen the four captive screws that secure the heatsink.

**Note** Alternate loosening the heatsink screws evenly so that the heatsink remains level as it is raised. Loosen the heatsink nuts in the order shown on the heatsink label (4, 3, 2, 1).

**Figure 19: Removing the Heatsink**



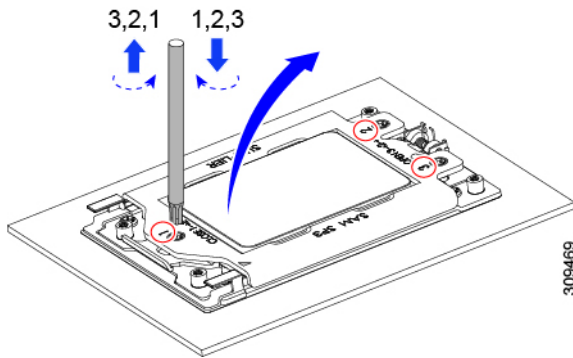
- b) Lift straight up on the heatsink and set it down on an antistatic surface. Use caution to avoid damaging the heatsink-to-CPU surface.

**Step 4** Remove the CPU from the socket:

- a) Use the T-20 Torx driver to loosen the three captive socket-frame screws in this order: 3, 2, 1.

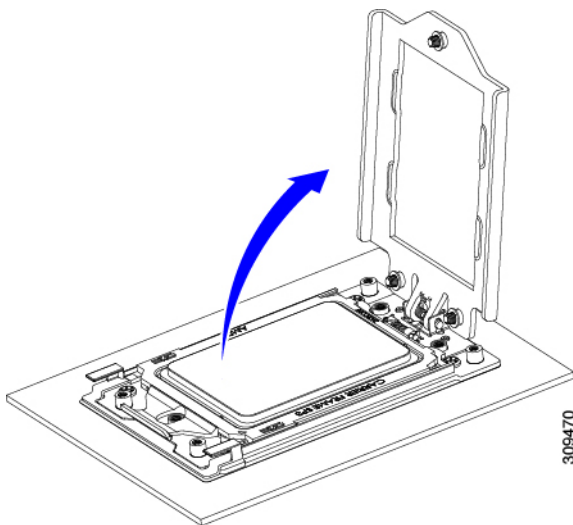


**Figure 20: Loosening the Socket Frame Screws**



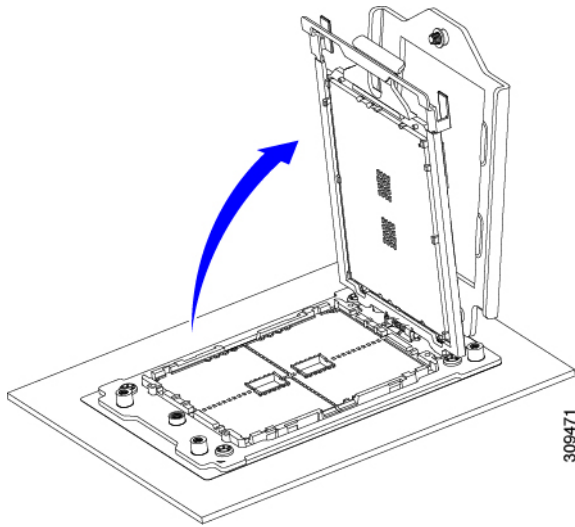
- b) Pivot the hinged socket frame to the upright position.

**Figure 21: Opening the Socket Frame**



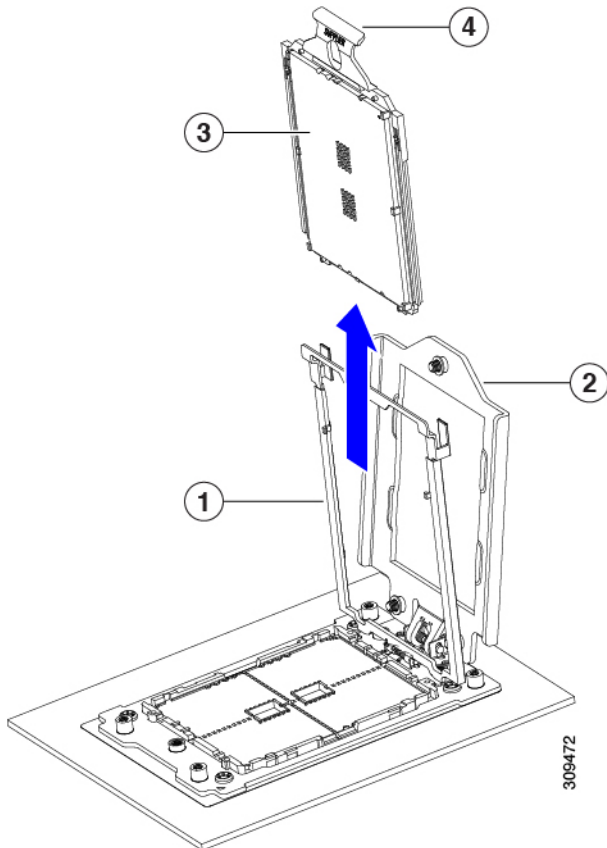
- c) Pivot the rail frame to the upright position.

Figure 22: Opening the Rail Frame



- d) Grasp the CPU only by the handling tab that is on its carrier frame and pull straight up to remove the CPU from the rail frame.

Figure 23: Removing the CPU From the Socket



<b>1</b>	Rail frame in open position	<b>3</b>	CPU in carrier frame
----------	-----------------------------	----------	----------------------

2	Socket frame in open position	4	Handling tab on CPU carrier frame
---	-------------------------------	---	-----------------------------------

**Step 5**

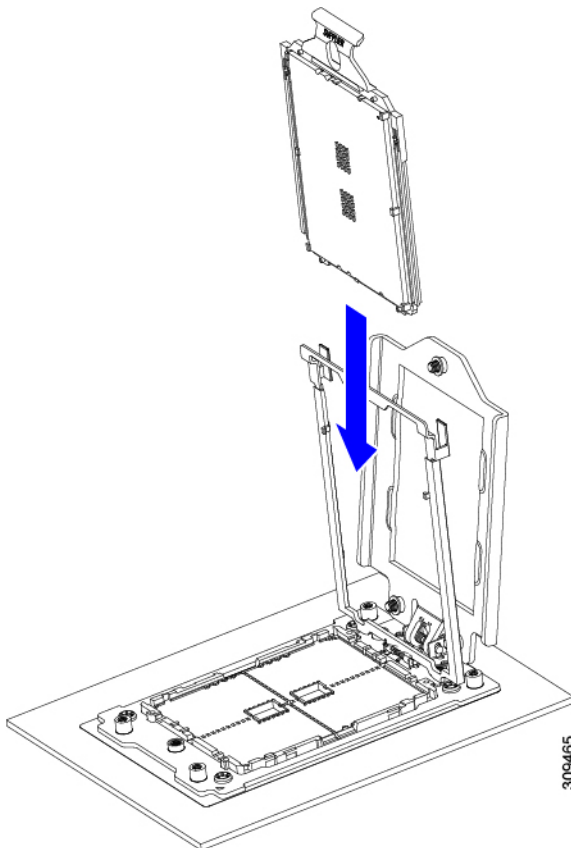
Install the new CPU:

**Caution** The CPU contacts and pins are extremely fragile. In this step, use extreme care to avoid touching or damaging the CPU contacts or the CPU socket pins.

**Note** Ensure that you are following the [CPU Configuration Rules, on page 51](#).

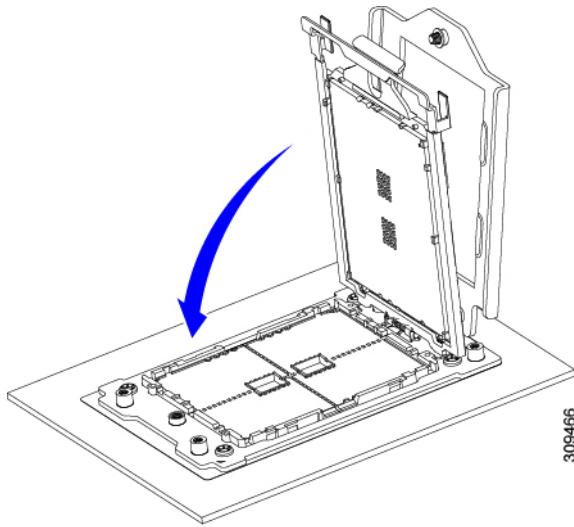
- a) Grasping the CPU only by the handling tab on its carrier frame, carefully slide it down into the open rail frame.

**Figure 24: Inserting the CPU with Carrier Frame**



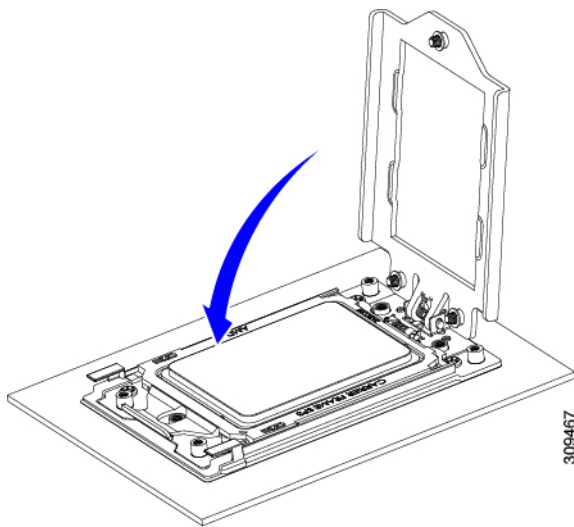
- a) Gently close the rail frame down to the flat, closed position.

**Figure 25: Closing the Rail Frame**



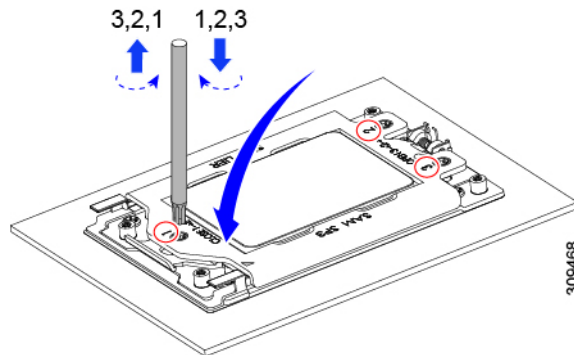
- b) Gently close the socket frame down to the flat, closed position.

**Figure 26: Closing the Socket Frame**



- c) Tighten the three screws on the socket frame in this order: 1, 2, 3.

Figure 27: Closing the Socket Frame

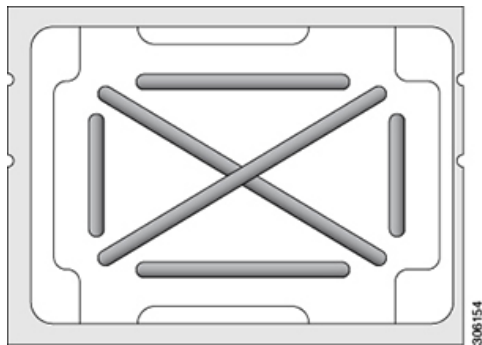


**Step 6** Apply new TIM to the heatsink:

**Note** The heatsink must have new TIM on the heatsink-to-CPU surface to ensure proper cooling and performance.

- If you are installing a new heatsink, it is shipped with a pre-applied pad of TIM. Go to step 7.
  - If you are reusing a heatsink, you must remove the old TIM from the heatsink and then apply new TIM to the CPU surface from the supplied syringe. Continue with step a below.
- a) Apply the cleaning solution that is included with the heatsink cleaning kit (UCSX-HSCK=) to the old TIM on the heatsink and let it soak for a least 15 seconds.
  - b) Wipe all of the TIM off the heatsink using the soft cloth that is included with the heatsink cleaning kit. Be careful to avoid scratching the heatsink surface.
  - c) Using the syringe of TIM provided with the new CPU (UCS-CPU-TIM=), apply 1.5 cubic centimeters (1.5ml) of thermal interface material to the top of the CPU. Use the pattern shown below to ensure even coverage.

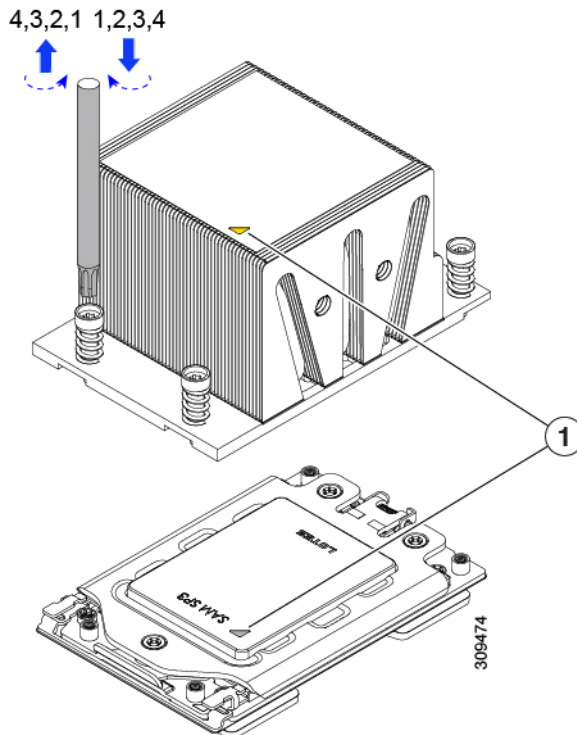
Figure 28: Thermal Interface Material Application Pattern



**Step 7** Install the heatsink to the CPU:

- a) Align the heatsink over the CPU socket. Align the triangle-mark on the heatsink with the triangle-mark on the socket frame, as shown in the following figure.

Figure 29: Heatsink Alignment Marks



1	Triangle marks on front heatsink UCSC-HSHP-C245M6 and CPU socket.
---	---

- b) Use a T-20 Torx driver to tighten the four captive screws that secure the heatsink.

**Caution** Alternate tightening the heatsink screws evenly so that the heatsink remains level while it is lowered. Tighten the heatsink screws in the order shown on the heatsink label (1, 2, 3, 4).

**Step 8** Reconnect any cables that you removed.

**Step 9** Power on the server.

## Additional CPU-Related Parts to Order with RMA Replacement CPUs or RMA Nodes

When a return material authorization (RMA) of the CPU is done on a node, additional parts might not be included with the CPU spare. The TAC engineer might need to add the additional parts to the RMA to help ensure a successful replacement.

- Scenario 1—You are reusing the existing heatsinks or moving CPUs and heatsinks to a new node:
  - Heatsink cleaning kit (UCSX-HSCK=)
    - One cleaning kit can clean up to four CPUs.
  - Thermal interface material (TIM) kit (UCS-CPU-TIM=)

One TIM kit covers one CPU.

- Scenario 2—You are replacing the existing heatsinks:
  - Heatsink: UCSC-HSHP-C245M6=
    - New heatsinks have a pre-applied pad of TIM.
  - Heatsink cleaning kit (UCSX-HSCK=)
    - One cleaning kit can clean up to four CPUs.

A CPU heatsink cleaning kit is good for up to four CPU and heatsink cleanings. The cleaning kit contains two bottles of solution, one to clean the CPU and heatsink of old TIM and the other to prepare the surface of the heatsink.

New heatsink spares come with a pre-applied pad of TIM. It is important to clean any old TIM off of the CPU surface prior to installing the heatsinks. Therefore, even when you are ordering new heatsinks, you must order the heatsink cleaning kit.

## Replacing Memory DIMMs




---

**Caution** DIMMs and their sockets are fragile and must be handled with care to avoid damage during installation.

---




---

**Caution** Cisco does not support third-party DIMMs. Using non-Cisco DIMMs in the server might result in system problems or damage to the motherboard.

---




---

**Note** To ensure the best server performance, it is important that you are familiar with memory performance guidelines and population rules before you install or replace DIMMs.

---

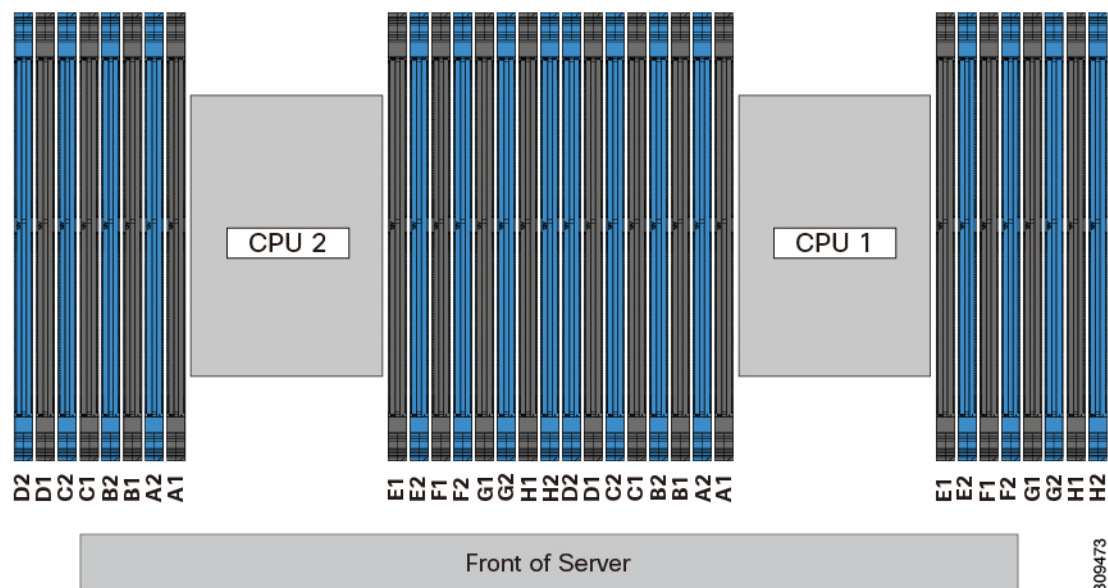
## DIMM Population Rules and Memory Performance Guidelines

This topic describes the rules and guidelines for maximum memory performance.

### DIMM Slot Numbering

The following figure shows the numbering of the DIMM slots on the motherboard.

Figure 30: DIMM Slot Numbering



### DIMM Population Rules

Observe the following guidelines when installing or replacing DIMMs for maximum performance:

- Each CPU supports eight memory channels, A through H.
  - CPU 1 supports channels P1 A1, P1 A2, P1 B1, P1 B2, P1 C1, P1 C2, P1 D1, P1 D2, P1 E1, P1 E2, P1 F1, P1 F2, P1 G1, P1 G2, P1 H1, and P1 H2.
  - CPU 2 supports channels P2 A1, P2 A2, P2 B1, P2 B2, P2 C1, P2 C2, P2 D1, P2 D2, P2 E1, P2 E2, P2 F1, P2 F2, P2 G1, P2 G2, P2 H1, and P2 H2.
- Each channel has two DIMM sockets (for example, channel A = slots A1, A2).
- When both CPUs are installed, populate the DIMM slots of each CPU identically.
- In a single-CPU configuration, populate the channels for CPU1 only (P1 A1 through P1 H2).
- For optimal performance, populate DIMMs in the order shown in the following table, depending on the number of CPUs and the number of DIMMs per CPU. If your server has two CPUs, balance DIMMs evenly across the two CPUs as shown in the table.



**Note** The sections below list recommended configurations. Using 5, 7, 9, 10, or 11 DIMMs per CPU is not recommended.

### Memory Population Order

Memory slots are color coded, blue and black. The color coded channel population order is blue slots first, then black.

The following tables show the memory population order for each memory option.



**Table 5: DIMMs Population Order for 2 CPU Configuration**

Number of DDR4 DIMMs per CPU (Recommended Configurations)	Populate CPU 1 Slot	Populate CPU2 Slots
1	P1_C2	P2_C2
2	P1_C2 P1_D2	P2_C2 P2_D2
4	P1_C2 P1_D2 P1_G2 P1_H2	P2_C2 P2_D2 P2_G2 P2_H2
6	P1_C2 P1_D2 P1_G2 P1_H2 P1_A2 P1_E2	P2_C2 P2_D2 P2_G2 P2_H2 P2_A2 P2_E2
8	P1_C2 P1_D2 P1_G2 P1_H2 P1_A2 P1_E2 P1_B2 P1_F2	P2_C2 P2_D2 P2_G2 P2_H2 P2_A2 P2_E2 P2_B2 P2_F2

<p>10</p>	<p>P1_C2 P1_D2 P1_G2 P1_H2 P1_A2 P1_E2 P1_B2 P1_F2 P1_D1 P1_E1</p>	<p>P2_C2 P2_D2 P2_G2 P2_H2 P2_A2 P2_E2 P2_B2 P2_F2 P2_D1 P2_E1</p>
<p>12</p>	<p>P1_C2 P1_D2 P1_G2 P1_H2 P1_A2 P1_E2 P1_B2 P1_F2 P1_D1 P1_E1 P1_B1 P1_G1</p>	<p>P2_C2 P2_D2 P2_G2 P2_H2 P2_A2 P2_E2 P2_B2 P2_F2 P2_D1 P2_E1 P2_B1 P2_G1</p>

14	P1_C2 P1_D2 P1_G2 P1_H2 P1_A2 P1_E2 P1_B2 P1_F2 P1_D1 P1_E1 P1_B1 P1_G1 P1_C1 P1_F1	P2_C2 P2_D2 P2_G2 P2_H2 P2_A2 P2_E2 P2_B2 P2_F2 P2_D1 P2_E1 P2_B1 P2_G1 P2_C1 P2_F1
16	All populated (A1,A2) through (H1, H2)	All populated (A1,A2) through (H1, H2)

Table 6: DIMMs Population Order for 1 CPU Configuration

Number of DDR4 DIMMs per CPU (Recommended Configurations)	Populate CPU 1 Slot
1	P1_C2
2	P1_C2 P1_D2
4	P1_C2 P1_D2 P1_G2 P1_H2
6	P1_C2 P1_D2 P1_G2 P1_H2 P1_A2 P1_E2

Number of DDR4 DIMMs per CPU (Recommended Configurations)	Populate CPU 1 Slot
8	P1_C2 P1_D2 P1_G2 P1_H2 P1_A2 P1_E2 P1_B2 P1_F2
10	P1_C2 P1_D2 P1_G2 P1_H2 P1_A2 P1_E2 P1_B2 P1_F2 P1_D1 P1_E1
12	P1_C2 P1_D2 P1_G2 P1_H2 P1_A2 P1_E2 P1_B2 P1_F2 P1_D1 P1_E1 P1_B1 P1_G1

Number of DDR4 DIMMs per CPU (Recommended Configurations)	Populate CPU 1 Slot
14	P1_C2 P1_D2 P1_G2 P1_H2 P1_A2 P1_E2 P1_B2 P1_F2 P1_D1 P1_E1 P1_B1 P1_G1 P1_C1 P1_F1
16	All populated (A1,A2) through (H1, H2)

- The maximum combined memory allowed in the 16 DIMM slots controlled by any one CPU is 16 x 256 GB.
- Memory mirroring reduces the amount of memory available by 50 percent because only one of the two populated channels provides data. When memory mirroring is enabled, you must install DIMMs in even numbers of channels.
- NVIDIA M-Series GPUs can support only less-than 1 TB memory in the server.
- NVIDIA P-Series GPUs can support 1 TB or more memory in the server.
- AMD FirePro S7150 X2 GPUs can support only less-than 1 TB memory in the server.
- Observe the DIMM mixing rules shown in the following table.

**Table 7: DIMM Mixing Rules**

DIMM Parameter	DIMMs in the Same Channel	DIMMs in the Same Bank
DIMM Capacity For example, 8GB, 16GB, 32GB, 64GB, 128GB	You can mix different capacity DIMMs in the same channel (for example, A1, A2).	You cannot mix DIMMs with different capacities and Revisions in the same bank (for example A1, B1). The Revision value depends on the manufactures. Two DIMMs with the same PID can have different Revisions.

DIMM speed For example, 2666 GHz	You can mix speeds, but DIMMs will run at the speed of the slowest DIMMs/CPUs installed in the channel.	You cannot mix DIMMs with different speeds and Revisions in the same bank (for example A1, B1). The Revision value depends on the manufactures. Two DIMMs with the same PID can have different Revisions.
DIMM type RDIMMs or LRDIMMs	You cannot mix DIMM types in a channel.	You cannot mix DIMM types in a bank.

### Memory Mirroring

The CPUs in the server support memory mirroring only when an even number of channels are populated with DIMMs. If one or three channels are populated with DIMMs, memory mirroring is automatically disabled.

Memory mirroring reduces the amount of memory available by 50 percent because only one of the two populated channels provides data. The second, duplicate channel provides redundancy.

## Replacing DIMMs

### Identifying a Faulty DIMM

Each DIMM socket has a corresponding DIMM fault LED, directly in front of the DIMM socket. See [Internal Diagnostic LEDs, on page 32](#) for the locations of these LEDs. When the server is in standby power mode, these LEDs light amber to indicate a faulty DIMM.

**Step 1** Remove an existing DIMM:

- Shut down and remove power from the server as described in [Shutting Down and Removing Power From the Server, on page 34](#).
- Slide the server out the front of the rack far enough so that you can remove the top cover. You might have to detach cables from the rear panel to provide clearance.
 

**Caution** If you cannot safely view and access the component, remove the server from the rack.
- Remove the top cover from the server as described in [Removing the Server Top Cover, on page 35](#).
- Remove the air baffle that covers the front ends of the DIMM slots to provide clearance.
- Locate the DIMM that you are removing, and then open the ejector levers at each end of its DIMM slot.

**Step 2** Install a new DIMM:

- Note** Before installing DIMMs, see the memory population rules for this server: [DIMM Population Rules and Memory Performance Guidelines , on page 59](#).
- Align the new DIMM with the empty slot on the motherboard. Use the alignment feature in the DIMM slot to correctly orient the DIMM.
  - Push down evenly on the top corners of the DIMM until it is fully seated and the ejector levers on both ends lock into place.
  - Replace the top cover to the server.

- d) Replace the server in the rack, replace cables, and then fully power on the server by pressing the Power button.

---

## Replacing a Mini-Storage Module

The mini-storage module plugs into a motherboard socket to provide additional internal storage.

- M.2 SSD Carrier—provides two M.2 form-factor SSD sockets.



---

**Note** The Cisco IMC firmware does not include an out-of-band management interface for the M.2 drives installed in the M.2 version of this mini-storage module (UCS-MSTOR-M2). The M.2 drives are not listed in Cisco IMC inventory, nor can they be managed by Cisco IMC. This is expected behavior.

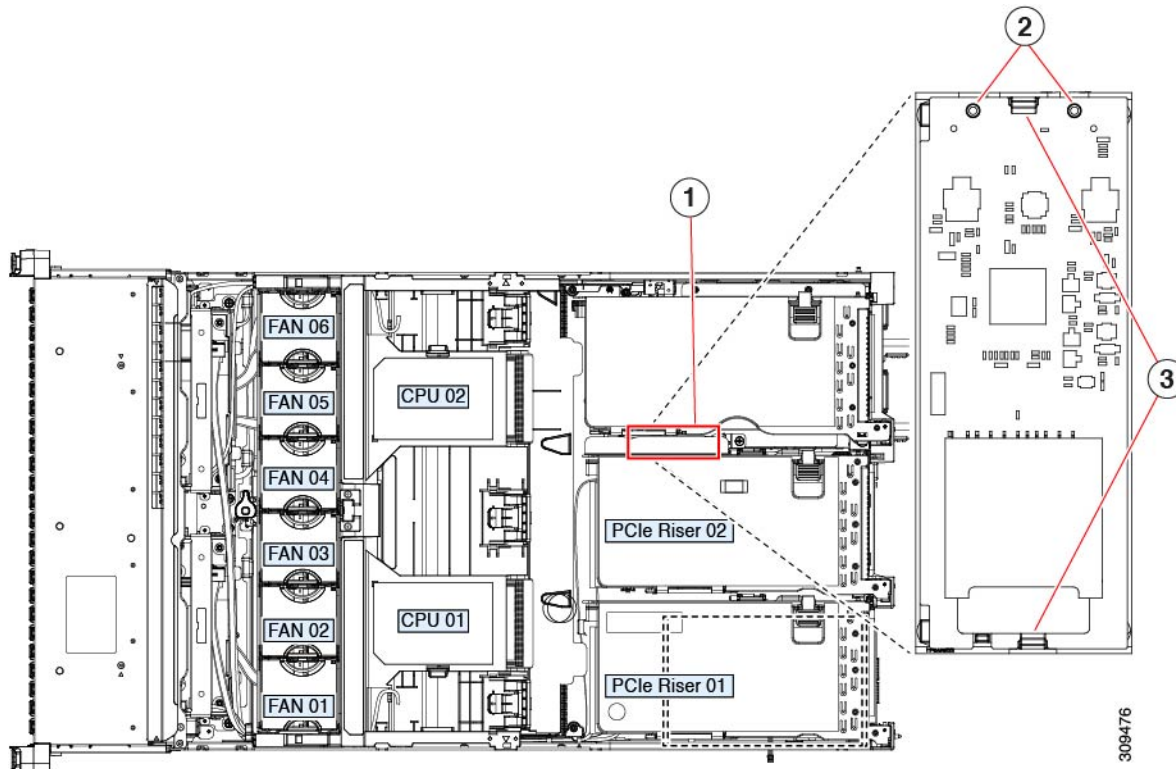
---

## Replacing a Mini-Storage Module Carrier

This topic describes how to remove and replace a mini-storage module carrier. The carrier has one media socket on its top and one socket on its underside. Use the following procedure for any type of mini-storage module carrier (M.2 SSD).

- 
- Step 1** Shut down and remove power from the server as described in [Shutting Down and Removing Power From the Server, on page 34](#).
- Step 2** Slide the server out the front of the rack far enough so that you can remove the top cover. You might have to detach cables from the rear panel to provide clearance.
- Caution** If you cannot safely view and access the component, remove the server from the rack.
- Step 3** Remove the top cover from the server as described in [Removing the Server Top Cover, on page 35](#).
- Step 4** Remove a carrier from its socket:
- Locate the mini-storage module carrier in its socket between Riser 2 and Riser 3.
  - Push outward on the securing clips that holds each end of the carrier.
  - Lift both ends of the carrier to disengage it from the socket on the motherboard.
  - Set the carrier on an anti-static surface.
- Step 5** Install a carrier to its socket:
- Position carrier over socket, with the carrier's connector facing down. Two alignment pegs must match with two holes on the carrier.
  - Gently push down the socket end of the carrier so that the two pegs go through the two holes on the carrier.
  - Push down on the carrier so that the securing clips click over it at both ends.
- Step 6** Replace the top cover to the server.
- Step 7** Replace the server in the rack, replace cables, and then fully power on the server by pressing the Power button.

Figure 31: Mini-Storage Module Carrier Socket



1	Location of socket on motherboard	3	Securing clips
2	Alignment pegs	-	

## Replacing an M.2 SSD in a Mini-Storage Carrier For M.2

This server supports Cisco Boot optimized M.2 RAID controller (holds 2 M.2 SATA SSDs). The UCS-M2-HWRAID controller is available only with 240 GB (UCS-M2-240GB=) and 960 GB (UCS-M2-960GB=) M.2 SSDs. This topic describes how to remove and replace an M.2 SATA SSD in a mini-storage carrier for M.2 (UCS-M2-HWRAID). The carrier has one M.2 SSD socket on its top and one socket on its underside.



**Note** Cisco recommends that you use M.2 SATA SSDs as boot-only devices.

### Population Rules For Mini-Storage M.2 SSDs

- Both M.2 SSDs must be of same capacity; do not mix different capacity SSDs.
- You can use one or two M.2 SSDs in the carrier.



- M.2 socket 1 is on the top side of the carrier; M.2 socket 2 is on the underside of the carrier (the same side as the carrier's motherboard connector).
- Dual SATA M.2 SSDs can be configured in a RAID 1 array through the BIOS Setup Utility's embedded SATA RAID interface.



---

**Note** You cannot control the M.2 SATA SSDs in the server with a HW RAID controller.

---

- 
- Step 1** Power off the server and then remove the mini-storage module carrier from the server as described in [Replacing a Mini-Storage Module Carrier, on page 67](#).
- Step 2** Remove an M.2 SSD:
- a) Use a #1 Phillips-head screwdriver to remove the single screw that secures the M.2 SSD to the carrier.
  - b) Remove the M.2 SSD from its socket on the carrier.
- Step 3** Install a new M.2 SSD:
- a) Insert the new M.2 SSD connector-end into the socket on the carrier with its label side facing up.
  - b) Press the M.2 SSD flat against the carrier.
  - c) Install the single screw that secures the end of the M.2 SSD to the carrier.
- Step 4** Install the mini-storage module carrier back into the server and then power it on as described in [Replacing a Mini-Storage Module Carrier, on page 67](#).
- 

## Replacing a USB Drive



---

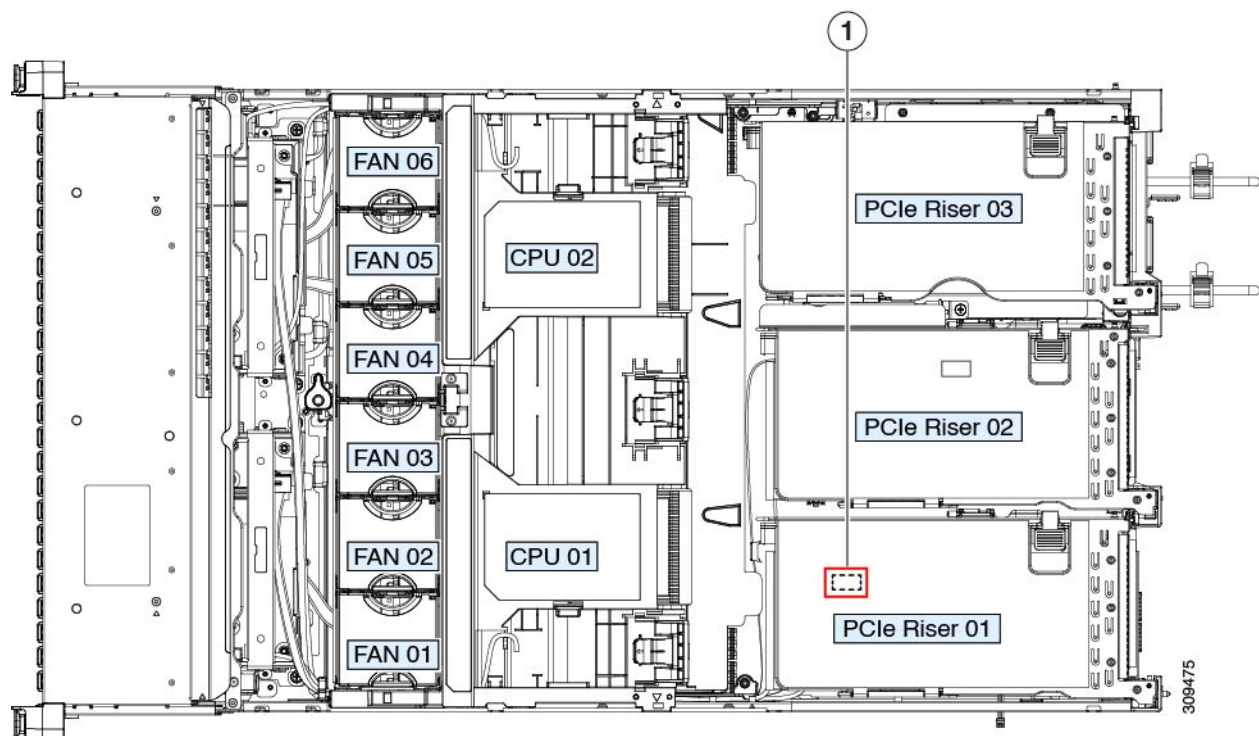
**Caution** We do not recommend that you hot-swap the internal USB drive while the server is powered on because of the potential for data loss.

---

- 
- Step 1** Remove an existing internal USB drive:
- a) Shut down and remove power from the server as described in [Shutting Down and Removing Power From the Server, on page 34](#).
  - b) Slide the server out the front of the rack far enough so that you can remove the top cover. You might have to detach cables from the rear panel to provide clearance.
- Caution** If you cannot safely view and access the component, remove the server from the rack.
- c) Remove the top cover from the server as described in [Removing the Server Top Cover, on page 35](#).
  - d) Locate the USB socket on the motherboard, under Riser 1.
  - e) Grasp the USB drive and pull it vertically to free it from the socket.
- Step 2** Install a new internal USB drive:
- a) Align the USB drive with the socket.

- b) Push the USB drive vertically to fully engage it with the socket.
- c) Replace the top cover to the server.
- d) Replace the server in the rack, replace cables, and then fully power on the server by pressing the Power button.

**Figure 32: Location of Internal USB Port**



1	Location of vertical USB socket on motherboard	-	
---	--	---	--

## Enabling or Disabling the Internal USB Port

The factory default is that all USB ports on the server are enabled. However, the internal USB port can be enabled or disabled in the server BIOS.

- Step 1** Enter the BIOS Setup Utility by pressing the **F2** key when prompted during bootup.
- Step 2** Navigate to the **Advanced** tab.
- Step 3** On the Advanced tab, select **USB Configuration**.
- Step 4** On the USB Configuration page, select **USB Ports Configuration**.
- Step 5** Scroll to **USB Port: Internal**, press **Enter**, and then choose either **Enabled** or **Disabled** from the dialog box.
- Step 6** Press **F10** to save and exit the utility.

# Replacing the RTC Battery



**Warning** There is danger of explosion if the battery is replaced incorrectly. Replace the battery only with the same or equivalent type recommended by the manufacturer. Dispose of used batteries according to the manufacturer's instructions.

[Statement 1015]



**Warning Recyclers:** Do not shred the battery! Make sure you dispose of the battery according to appropriate regulations for your country or locale.

The real-time clock (RTC) battery retains system settings when the server is disconnected from power. The battery type is CR2032. Cisco supports the industry-standard CR2032 battery, which can be purchased from most electronic stores.

## Step 1

Remove the RTC battery:

- a) Shut down and remove power from the server as described in [Shutting Down and Removing Power From the Server, on page 34](#).
- b) Slide the server out the front of the rack far enough so that you can remove the top cover. You might have to detach cables from the rear panel to provide clearance.

**Caution** If you cannot safely view and access the component, remove the server from the rack.

- c) Remove the top cover from the server as described in [Removing the Server Top Cover, on page 35](#).
- d) Remove PCIe riser 1 from the server to provide clearance to the RTC battery socket that is on the motherboard. See [Replacing a PCIe Riser, on page 77](#).
- e) Locate the horizontal RTC battery socket.
- f) Remove the battery from the socket on the motherboard. Gently pry the securing clip to the side to provide clearance, then lift up on the battery.

## Step 2

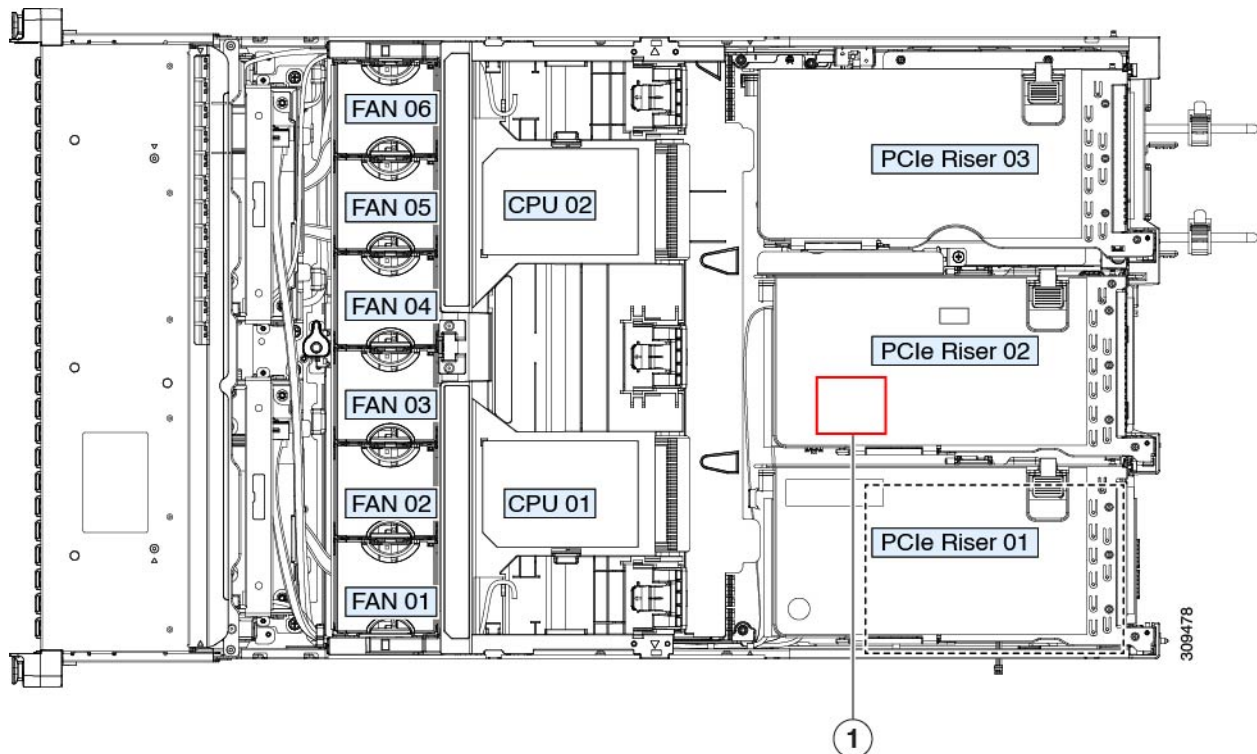
Install a new RTC battery:

- a) Insert the battery into its socket and press down until it clicks in place under the clip.

**Note** The positive side of the battery marked "3V+" should face up.

- b) Replace PCIe riser 1 to the server. See [Replacing a PCIe Riser, on page 77](#).
- c) Replace the top cover to the server.
- d) Replace the server in the rack, replace cables, and then fully power on the server by pressing the Power button.

Figure 33: RTC Battery Location on Motherboard



1	RTC battery in horizontal socket on motherboard	-	
---	---	---	--

## Replacing Power Supplies

When two power supplies are installed they are redundant as 1+1 by default, but they also support cold redundancy mode. Cold redundancy (CR) suspends power delivery on one or more power supplies and forces the remainder of the load to be supplied by the active PSU(s). As a result, total power efficiency is improved by best utilizing the PSU efficiency when compared to load characteristics.

- See also [Power Specifications](#), on page 112
- See also [Rear-Panel LEDs](#), on page 31 for information about the power supply LEDs.

This section includes procedures for replacing AC and DC power supply units.

## Installing DC Power Supplies (First Time Installation)



**Note** This procedure is for installing DC power supplies to the server for the first time. If you are replacing DC power supplies in a server that already has DC power supplies installed, see [Replacing DC Power Supplies, on page 75](#).



**Warning** A readily accessible two-poled disconnect device must be incorporated in the fixed wiring.

Statement 1022



**Warning** This product requires short-circuit (overcurrent) protection, to be provided as part of the building installation. Install only in accordance with national and local wiring regulations.

Statement 1045



**Warning** Installation of the equipment must comply with local and national electrical codes.

Statement 1074



**Note** Do not mix power supply types or wattages in the server. Both power supplies must be identical.



**Caution** As instructed in the first step of this wiring procedure, turn off the DC power source from your facility's circuit breaker to avoid electric shock hazard.

**Step 1** Turn off the DC power source from your facility's circuit breaker to avoid electric shock hazard.

**Note** The required DC input cable is Cisco part CAB-48DC-40A-8AWG. This 3-meter cable has a 3-pin connector on one end that is keyed to the DC input socket on the power supply. The other end of the cable has no connector so that you can wire it to your facility's DC power.

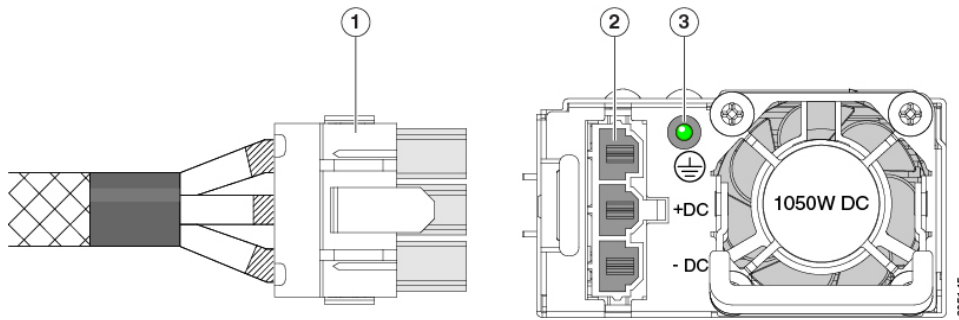
**Step 2** Wire the non-terminated end of the cable to your facility's DC power input source.

**Step 3** Connect the terminated end of the cable to the socket on the power supply. The connector is keyed so that the wires align for correct polarity and ground.

**Step 4** Return DC power from your facility's circuit breaker.

**Step 5** Press the Power button to boot the server to main power mode.

Figure 34: Replacing DC Power Supplies



1	Keyed cable connector (CAB-48DC-40A-8AWG)	3	PSU status LED
2	Keyed DC input socket	-	

**Step 6** See [Grounding for DC Power Supplies, on page 76](#) for information about additional chassis grounding.

## Replacing AC Power Supplies



**Note** If you have ordered a server with power supply redundancy (two power supplies), you do not have to power off the server to replace a power supply because they are redundant as 1+1.



**Note** Do not mix power supply types or wattages in the server. Both power supplies must be identical.

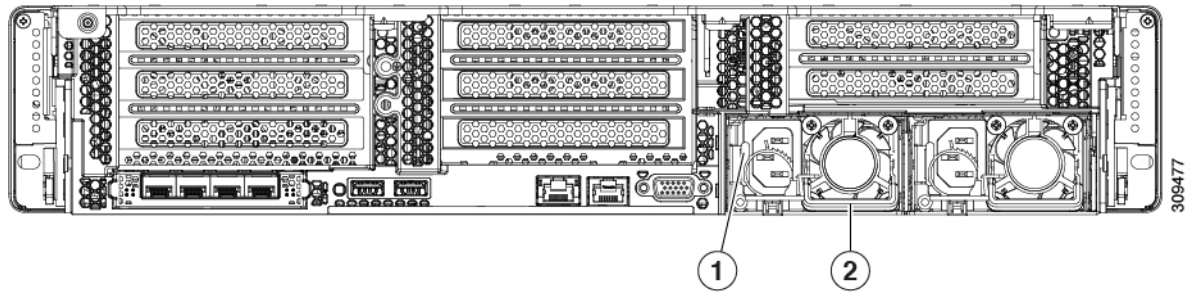
**Step 1** Remove the power supply that you are replacing or a blank panel from an empty bay:

- a) Perform one of the following actions:
  - If your server has only one power supply, shut down and remove power from the server as described in [Shutting Down and Removing Power From the Server, on page 34](#).
  - If your server has two power supplies, you do not have to shut down the server.
- b) Remove the power cord from the power supply that you are replacing.
- c) Grasp the power supply handle while pinching the release lever toward the handle.
- d) Pull the power supply out of the bay.

**Step 2** Install a new power supply:

- a) Grasp the power supply handle and insert the new power supply into the empty bay.
- b) Push the power supply into the bay until the release lever locks.
- c) Connect the power cord to the new power supply.
- d) Only if you shut down the server, press the Power button to boot the server to main power mode.

Figure 35: Replacing AC Power Supplies



1	Power supply release lever	2	Power supply handle
---	----------------------------	---	---------------------

## Replacing DC Power Supplies



**Note** This procedure is for replacing DC power supplies in a server that already has DC power supplies installed. If you are installing DC power supplies to the server for the first time, see [Installing DC Power Supplies \(First Time Installation\)](#), on page 73.



**Warning** A readily accessible two-poled disconnect device must be incorporated in the fixed wiring.  
Statement 1022



**Warning** This product requires short-circuit (overcurrent) protection, to be provided as part of the building installation. Install only in accordance with national and local wiring regulations.  
Statement 1045



**Warning** Installation of the equipment must comply with local and national electrical codes.  
Statement 1074



**Note** If you are replacing DC power supplies in a server with power supply redundancy (two power supplies), you do not have to power off the server to replace a power supply because they are redundant as 1+1.



**Note** Do not mix power supply types or wattages in the server. Both power supplies must be identical.

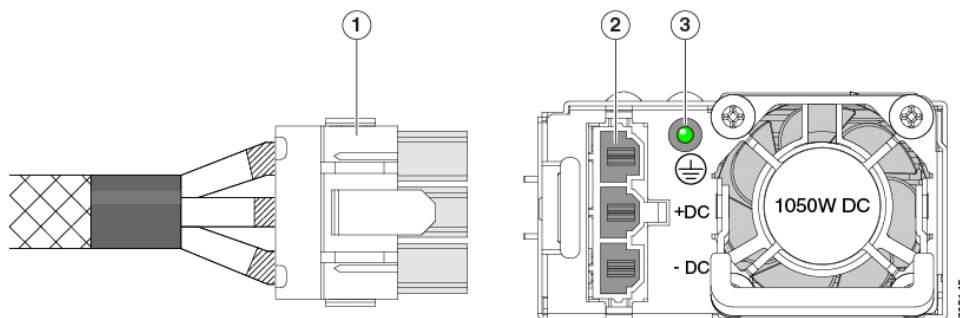
**Step 1** Remove the DC power supply that you are replacing or a blank panel from an empty bay:

- a) Perform one of the following actions:
  - If you are replacing a power supply in a server that has only one DC power supply, shut down and remove power from the server as described in [Shutting Down and Removing Power From the Server, on page 34](#).
  - If you are replacing a power supply in a server that has two DC power supplies, you do not have to shut down the server.
- b) Remove the power cord from the power supply that you are replacing. Lift the connector securing clip slightly and then pull the connector from the socket on the power supply.
- c) Grasp the power supply handle while pinching the release lever toward the handle.
- d) Pull the power supply out of the bay.

**Step 2** Install a new DC power supply:

- a) Grasp the power supply handle and insert the new power supply into the empty bay.
- b) Push the power supply into the bay until the release lever locks.
- c) Connect the power cord to the new power supply. Press the connector into the socket until the securing clip clicks into place.
- d) Only if you shut down the server, press the Power button to boot the server to main power mode.

**Figure 36: Replacing DC Power Supplies**



<b>1</b>	Keyed cable connector (CAB-48DC-40A-8AWG)	<b>3</b>	PSU status LED
<b>2</b>	Keyed DC input socket	-	

## Grounding for DC Power Supplies

AC power supplies have internal grounding and so no additional grounding is required when the supported AC power cords are used.



When using a DC power supply, additional grounding of the server chassis to the earth ground of the rack is available. Two screw holes for use with your dual-hole grounding lug and grounding wire are supplied on the chassis rear panel.



**Note** The grounding points on the chassis are sized for M5 screws. You must provide your own screws, grounding lug, and grounding wire. The grounding lug must be dual-hole lug that fits M5 screws. The grounding cable that you provide must be 14 AWG (2 mm), minimum 60° C wire, or as permitted by the local code.

## Replacing a PCIe Riser

This server has two toolless PCIe risers for horizontal installation of PCIe cards. Each riser is available in multiple versions. See [PCIe Slot Specifications, on page 86](#) for detailed descriptions of the slots and features in each riser version.

**Step 1** Shut down and remove power from the server as described in [Shutting Down and Removing Power From the Server, on page 34](#).

**Step 2** Slide the server out the front of the rack far enough so that you can remove the top cover. You might have to detach cables from the rear panel to provide clearance.

**Caution** If you cannot safely view and access the component, remove the server from the rack.

**Step 3** Remove the top cover from the server as described in [Removing the Server Top Cover, on page 35](#).

**Step 4** Remove the PCIe riser that you are replacing:

- Grasp the flip-up handle on the riser and the blue forward edge, and then lift up evenly to disengage its circuit board from the socket on the motherboard. Set the riser on an antistatic surface.
- If the riser has a card installed, remove the card from the riser. See [Replacing a PCIe Card, on page 88](#).

**Step 5** Install a new PCIe riser:

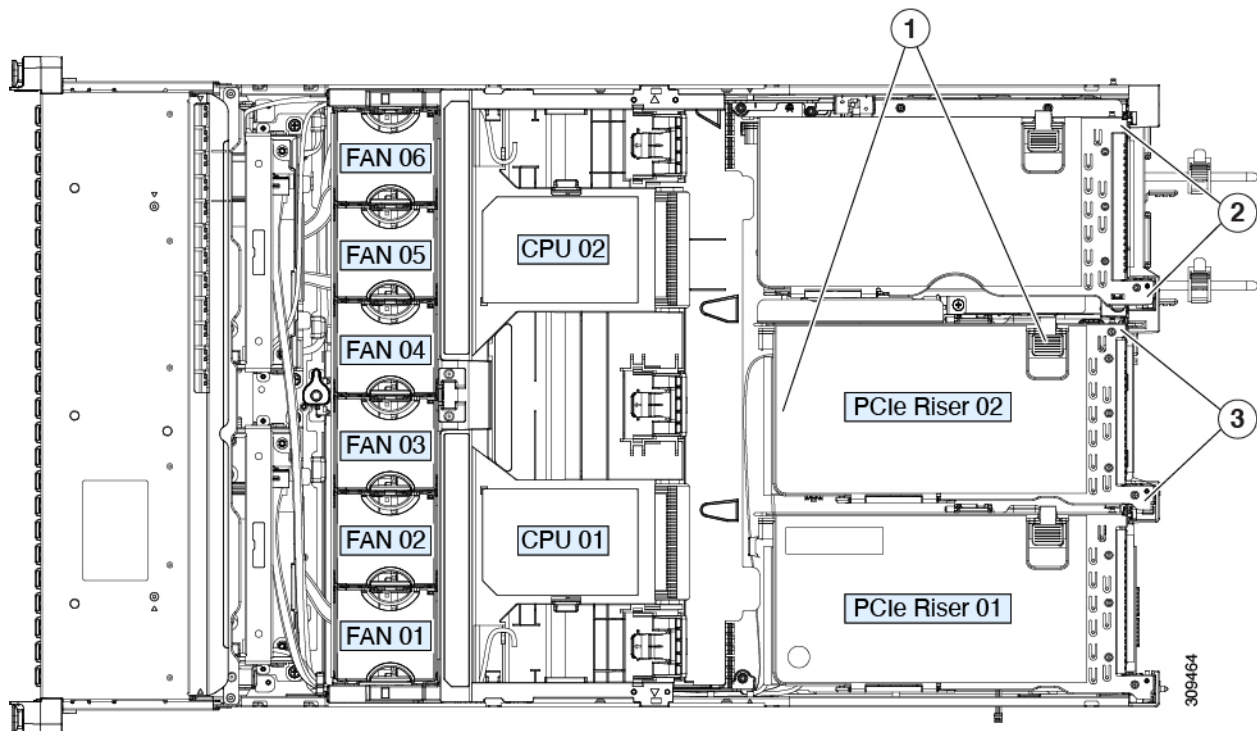
**Note** The PCIe risers are not interchangeable. If you plug a PCIe riser into the wrong socket, the server will not boot. Riser 1 must plug into the motherboard socket labeled “RISER1.” Riser 2 must plug into the motherboard socket labeled “RISER2.”

- If you removed a card from the old PCIe riser, install the card to the new riser. See [Replacing a PCIe Card, on page 88](#).
- Position the PCIe riser over its socket on the motherboard and over its alignment slots in the chassis.
- Carefully push down on both ends of the PCIe riser to fully engage its circuit board connector with the socket on the motherboard.

**Step 6** Replace the top cover to the server.

**Step 7** Replace the server in the rack, replace cables, and then fully power on the server by pressing the Power button.

Figure 37: PCIe Riser Alignment Features



1	Riser handling points (flip-up handle and blue forward edge)	3	Riser 2 alignment features in chassis
2	Riser 3 alignment features in chassis		

## Replacing NVMe Cable

When you order front-facing NVMe drives with or without raid controller (UCSC-RAID-M6SD), an NVMe cable (PID: CBL-SDFNVME-245M6) is included along with the drives.

When you order front-facing NVMe drives with dual SAS HBAs (UCSC-SAS-240M6), an NVMe cable (PID: CBL-FNVME-C245M6) is included along with the drives.

If you decide to add front-facing NVMe drives later, you may need to order the drives as spare and also an NVMe cable (PID: CBL-SDFNVME-245M6= or CBL-FNVME-C245M6=). Spare NVMe cables supports depends on the drive controller installing/installed in the system.

**Step 1** Prepare the server for component installation:

- Shut down and remove power from the server as described in [Shutting Down and Removing Power From the Server, on page 34](#).
- Slide the server out the front of the rack far enough so that you can remove the top cover. You might have to detach cables from the rear panel to provide clearance.

**Caution** If you cannot safely view and access the component, remove the server from the rack.

- c) Remove the top cover from the server as described in [Removing the Server Top Cover, on page 35](#).
- d) Remove Riser 2 and Riser 3 as described in [Replacing a PCIe Riser, on page 77](#).
- e) Remove the air baffle to provide clearance.
- f) Remove the PSU air baffle.
- g) Remove the complete fan module as described in [Replacing Fan Modules, on page 49](#)

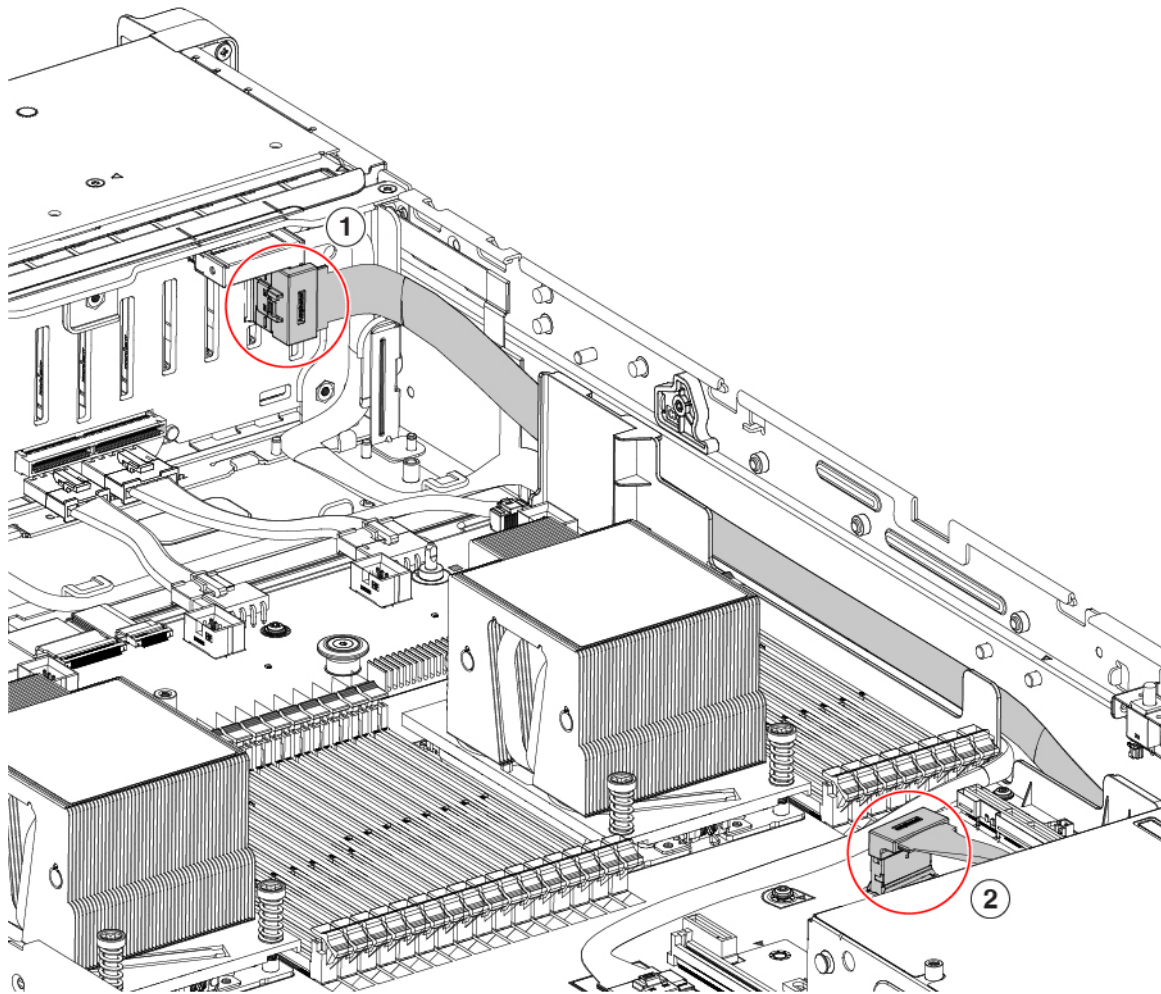
**Step 2**

Replacing the cable for a setup with or without 12G SAS RAID controller (UCSC-RAID-M6SD) configuration:

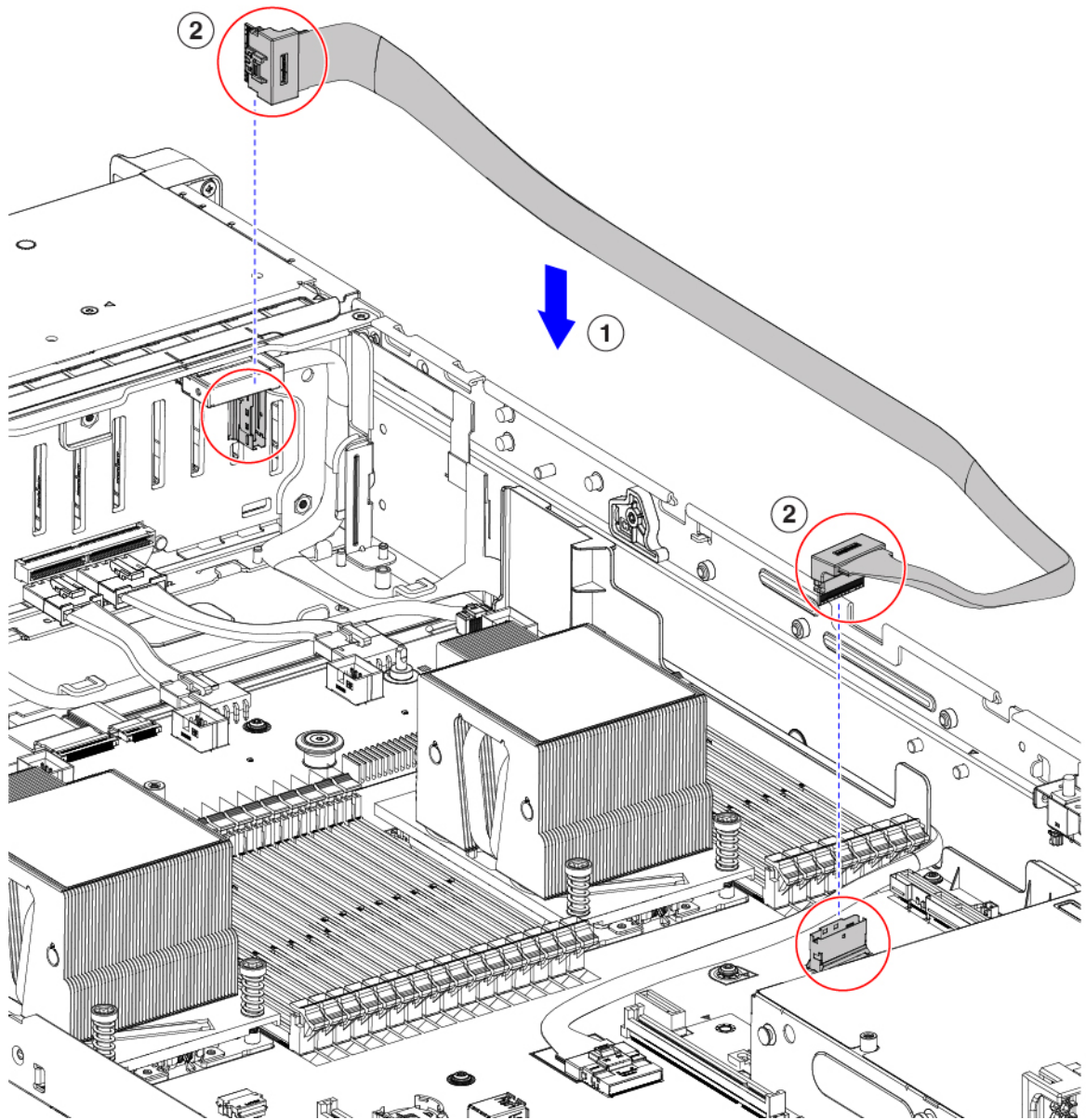
- Required Cable PID: CBL-SDFNVME-245M6=
- This cable set plugs into NVMe-C on motherboard (MB) side, and NVMe-C on backplane (BP) side and controls drives 1-2. Refer the below table and image for cabling.

1	NVMe-C on backplane (BP) side
2	NVMe-C on motherboard (MB)

Figure 38: NVMe-C on MB side and NVMe-C on BP



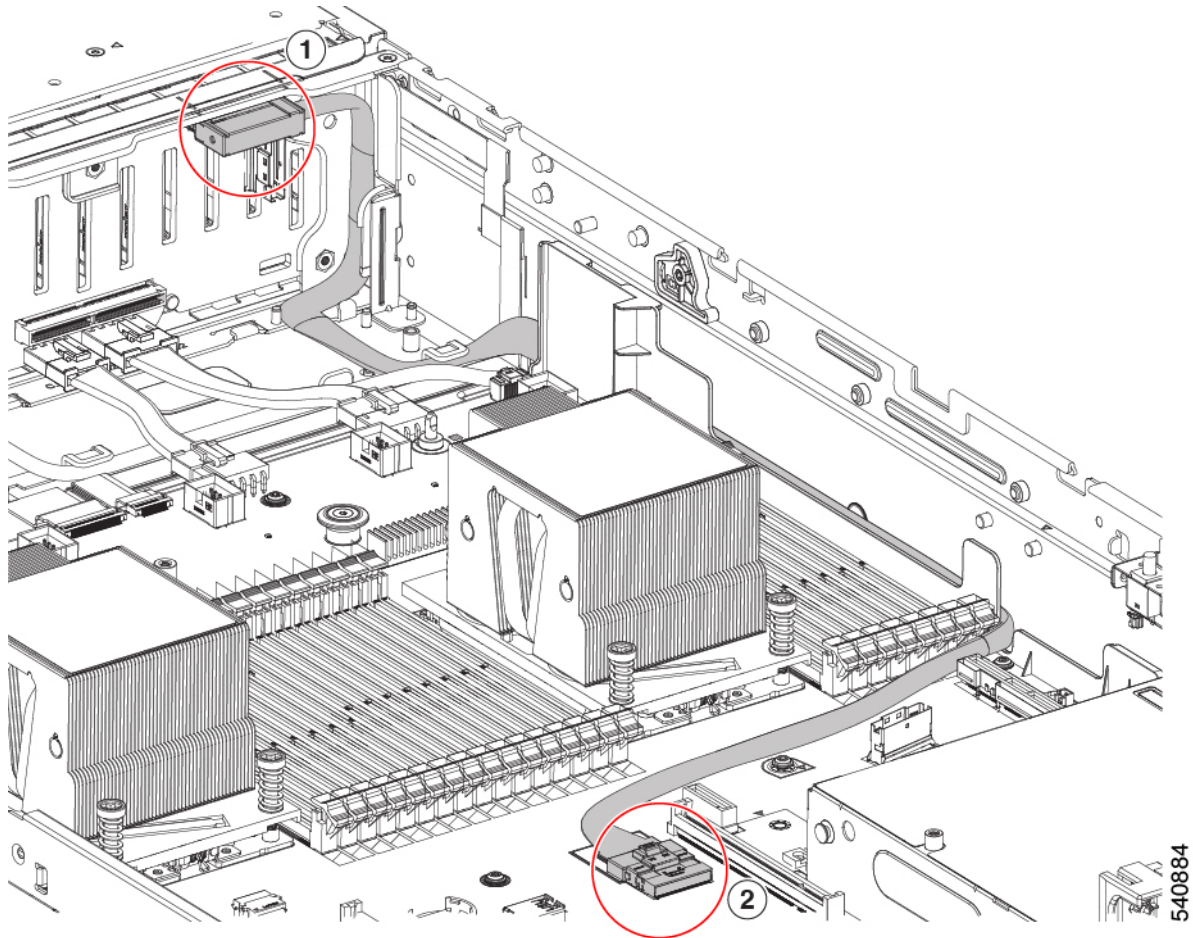
540886



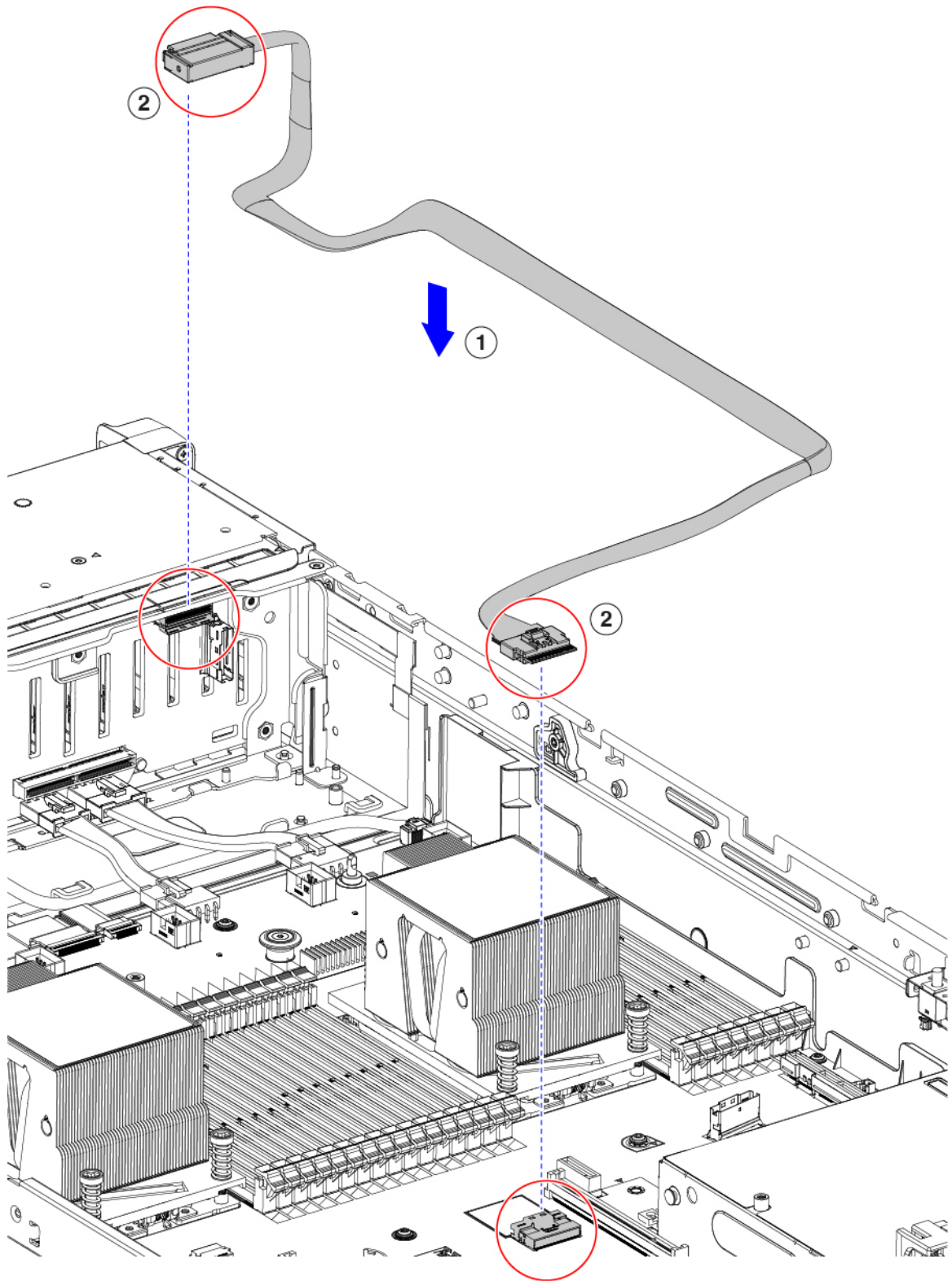
- This cable set plugs into NVMe-B on MB side, and NVMe-D on BP side and controls drives 3-4.

1	NVMe-D on BP side
2	NVMe-B on MB side

Figure 39: NVMe-B on MB side and NVMe-D on BP



540884



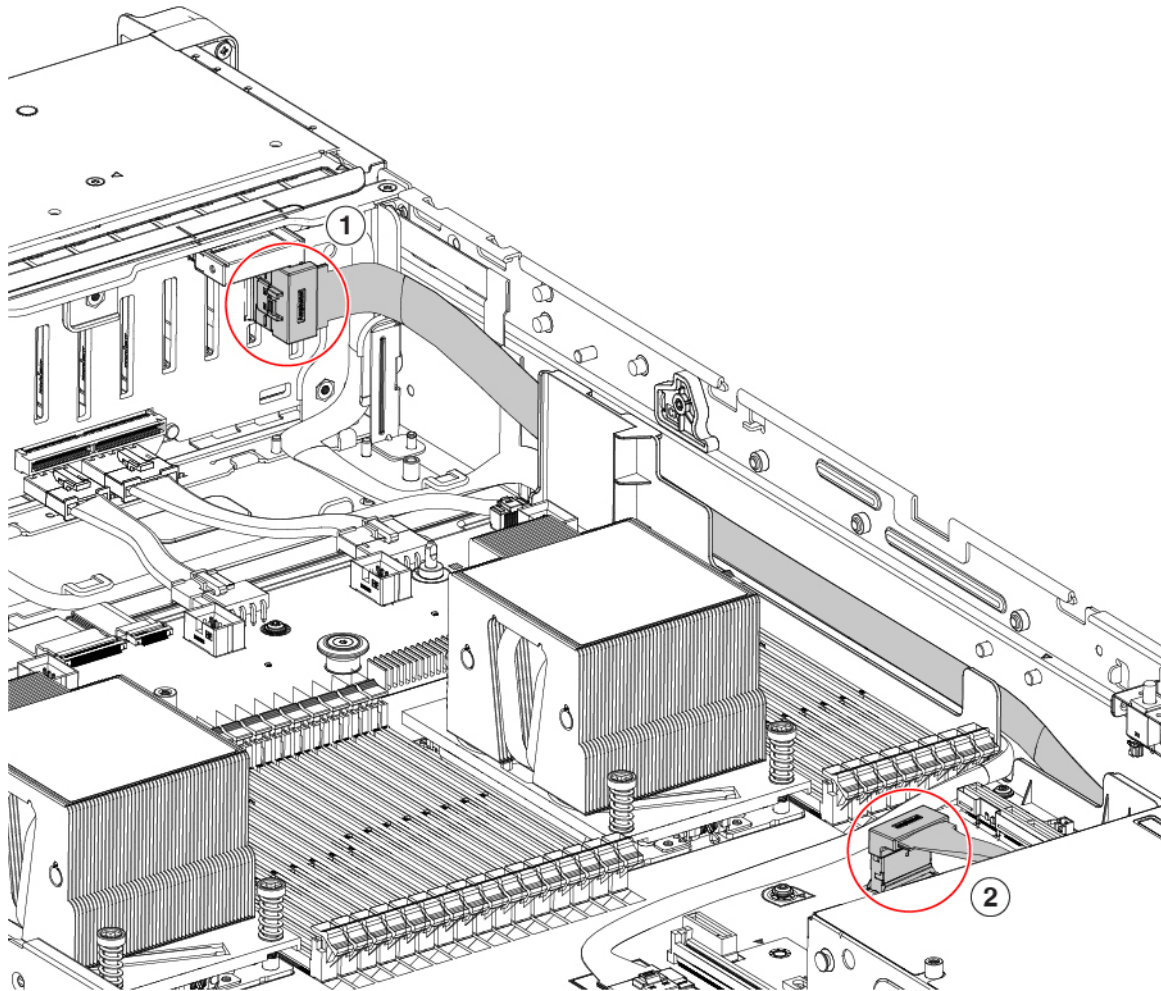
540883

**Step 3** Replacing the cable for a setup with Dual SAS HBA(UCSC-SAS-240M6) configuration:

- Required Cable PID: CBL-FNVME-C245M6=
- This cable plugs into NVMe-C on MB CPU2 to NVMe-C and D on SFF BP and connects to drives HDD1~2 and HDD3~4.

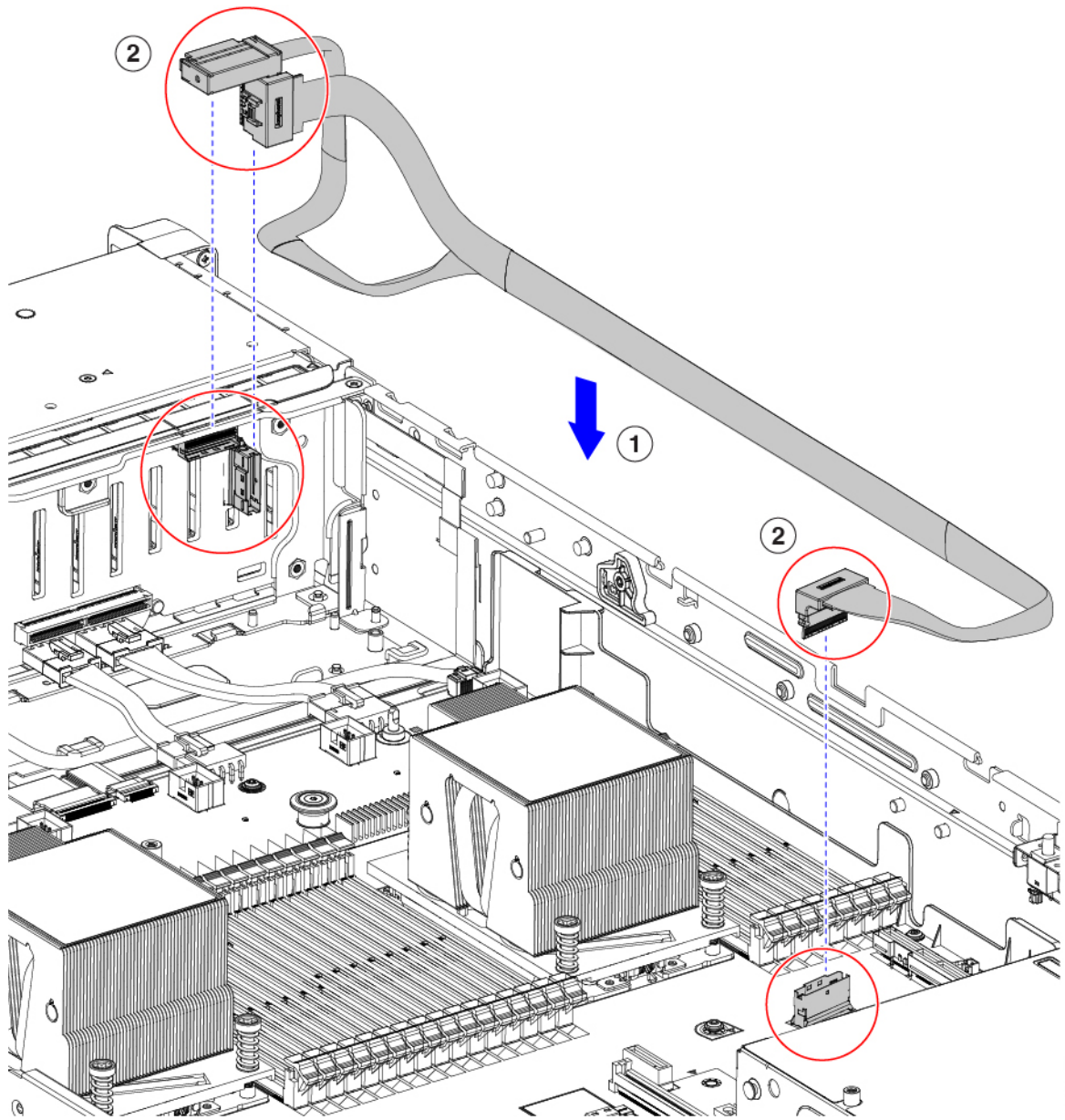
1	NVMe-C and D on SFF BP
2	NVMe-C on MB CPU2

Figure 40: NVMe-C on MB CPU2 to NVMe-C and D on SFF BP



540882





540881

# Replacing a PCIe Card

## PCIe Slot Specifications



**Note** Cisco supports all PCIe cards qualified and sold by Cisco. PCIe cards not qualified or sold by Cisco are the responsibility of the customer. Although Cisco will always stand behind and support the C-Series rack-mount servers, customers using standard, off-the-shelf, third-party cards must go to the third-party card vendor for support if any issue with that particular card occurs.

The server contains three toolless PCIe risers for horizontal installation of PCIe cards. Each riser is orderable in multiple versions.

- Riser 1—Supports Riser 1A and 1B. PCIe slots 1, 2, and 3 numbered bottom to top with the following options:
  - Riser 1A (UCSC-RIS1A-240M6)—Slot 1 PCIe supports full height, full length PCIe Add-in-card; Slot 2 PCIe supports full height, full length PCIe Add-in-card; Slot 3 PCIe supports full height, full length PCIe Add-in-card.
  - Riser 1B (UCSC-RIS1B-245M6) (Storage Option)—Slot 1 PCIe is disabled; Slot 2 supports 2.5-inch NVMe SSD; Slot 3 supports 2.5-inch NVMe SSD.
- Riser 2—Supports Riser 2A. PCIe slots 4, 5, and 6 numbered bottom to top with the following options:
  - Riser 2A (UCSC-RIS2A-240M6)—Slot 4, 5, and 6 PCIe support full height, full length PCIe Add-in-card.
- Riser 3—Supports Riser 3A, 3B and 3C. PCIe slots 7 and 8 numbered bottom to top with the following options:
  - Riser 3A—Slot 7 PCIe supports full height, full length PCIe Add-in-card; Slot 8 PCIe supports full height, full length PCIe Add-in-card.
  - Riser 3B—Slot 7 supports 2.5-inch NVMe SSD; Slot 8 supports 2.5-inch NVMe SSD.
  - Riser 3C—Slot 7 PCIe supports full height, full length PCIe Add-in-card.

The following tables describe the specifications for the slots.

**Table 8: PCIe Riser 1A (UCSC-RIS1A-240M6) PCIe Expansion Slots**

Slot Number	Electrical Lane Width	Connector Length	Maximum Card Length	Card Height (Rear Panel Opening)	NCSI Support	Double-Wide GPU Card Support
1	Gen-3 and Gen-4 x8	x24 connector	¾ length	Full height	Yes <sup>1</sup>	No
2	Gen-3 and Gen-4 x16	x24 connector	Full length	Full height	Yes	Yes

3 <sup>2</sup>	Gen-3 and Gen-4 x8	x16 connector	Full length	Full height	No	No
----------------	--------------------	---------------	-------------	-------------	----	----

<sup>1</sup> NCSI is supported in only one slot at a time. If a GPU card is present in slot 2, NCSI support automatically moves to slot 1.

<sup>2</sup> Slot 3 is not available in a single-CPU system.

**Table 9: PCIe Riser 1B (UCSC-RIS1B-240M6) PCIe Expansion Slots (Storage)**

Slot Number	Electrical Lane Width	Maximum Card Length
1	Disabled	
2	Gen-3 and Gen-4 x4	2.5” drive bay 102
3	Gen-3 and Gen-4 x4	2.5” drive bay 102



**Note** Riser 2 is not available in a single-CPU system.

**Table 10: PCIe Riser 2A (UCSC-RIS2A-240M6) PCIe Expansion Slots**

Slot Number	Electrical Lane Width	Connector Length	Maximum Card Length	Card Height (Rear Panel Opening)	NCSI Support	Double-Wide GPU Card Support
1	Gen-3 and Gen-4 x8	x24 connector	¾ length	Full height	Yes <sup>3</sup>	No
2	Gen-3 and Gen-4 x16	x24 connector	Full length	Full height	Yes	Yes
3 <sup>4</sup>	Gen-3 and Gen-4 x8	x16 connector	Full length	Full height	No	No

<sup>3</sup> NCSI is supported in only one slot at a time. If a GPU card is present in slot 2, NCSI support automatically moves to slot 1.

<sup>4</sup> Slot 3 is not available in a single-CPU system.

**Table 11: PCIe Riser 3A (UCSC-RIS3A-240M6) PCIe Expansion Slots**

Slot Number	Electrical Lane Width	Connector Length	Maximum Card Length	Card Height (Rear Panel Opening)	NCSI Support	Double-Wide GPU Card Support
7	Gen-3 and Gen-4 x8	x24 connector	Full length	Full height	No	No
8	Gen-3 and Gen-4 x8	x24 connector	Full length	Full height	No	No

**Table 12: PCIe Riser 3B (UCSC-RIS3B-240M6) PCIe Expansion Slots (Storage)**

Slot Number	Electrical Lane Width	Maximum Card Length
-------------	-----------------------	---------------------

7	Gen-3 and Gen-4 x4	2.5" drive bay 102
8	Gen-3 and Gen-4 x4	2.5" drive bay 102

**Table 13: PCIe Riser 3C (Not Orderable Separately) PCIe Expansion Slots**

Slot Number	Electrical Lane Width	Connector Length	Maximum Card Length	Card Height (Rear Panel Opening)	NCSI Support	Double-Wide GPU Card Support
7	Gen-3 and Gen-4 x16	x24 connector	Full length	Full height	Yes	Yes
8	Blocked by Double-Wide GPU Card					

## Replacing a PCIe Card



**Note** If you are installing a Cisco UCS Virtual Interface Card, there are prerequisite considerations. See [Cisco Virtual Interface Card \(VIC\) Considerations, on page 90](#).



**Note** RAID controller cards install into a dedicated motherboard socket. See [Replacing Front-Loading SAS/SATA Drives, on page 40](#).



**Note** For instructions on installing or replacing double-wide GPU cards, see [GPU Installation, on page 119](#).

- Step 1** Shut down and remove power from the server as described in [Shutting Down and Removing Power From the Server, on page 34](#).
- Step 2** Slide the server out the front of the rack far enough so that you can remove the top cover. You might have to detach cables from the rear panel to provide clearance.
- Caution** If you cannot safely view and access the component, remove the server from the rack.
- Step 3** Remove the top cover from the server as described in [Removing the Server Top Cover, on page 35](#).
- Step 4** Remove the PCIe card that you are replacing:
- Remove any cables from the ports of the PCIe card that you are replacing.
  - Use two hands to flip up and grasp the blue riser handle and the blue finger grip area on the front edge of the riser, and then lift straight up.
  - On the bottom of the riser, push the release latch that holds the securing plate, and then swing the hinged securing plate open.
  - Open the hinged card-tab retainer that secures the rear-panel tab of the card.

- e) Pull evenly on both ends of the PCIe card to remove it from the socket on the PCIe riser.  
If the riser has no card, remove the blanking panel from the rear opening of the riser.

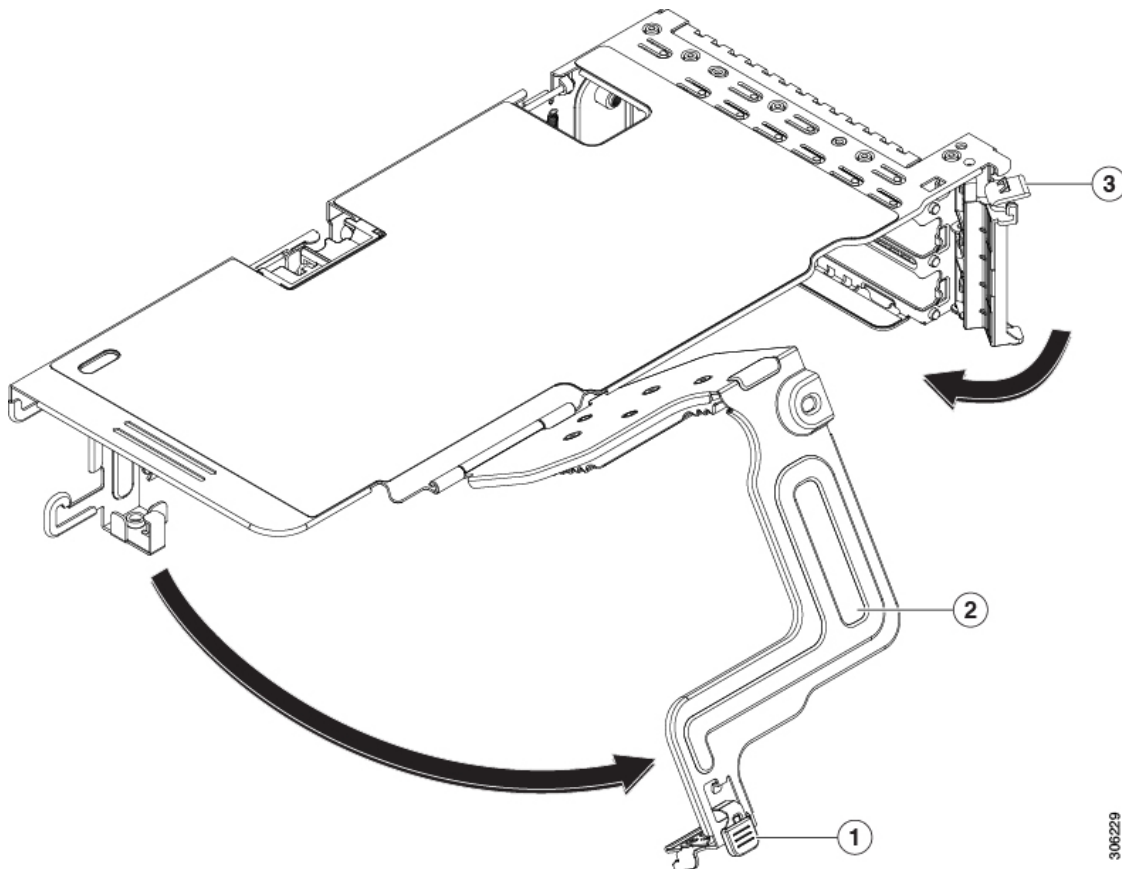
**Step 5** Install a new PCIe card:

- a) With the hinged card-tab retainer open, align the new PCIe card with the empty socket on the PCIe riser.
- b) Push down evenly on both ends of the card until it is fully seated in the socket.
- c) Ensure that the card's rear panel tab sits flat against the riser rear-panel opening and then close the hinged card-tab retainer over the card's rear-panel tab.
- d) Swing the hinged securing plate closed on the bottom of the riser. Ensure that the clip on the plate clicks into the locked position.
- e) Position the PCIe riser over its socket on the motherboard and over the chassis alignment channels.
- f) Carefully push down on both ends of the PCIe riser to fully engage its connector with the sockets on the motherboard.

**Step 6** Replace the top cover to the server.

**Step 7** Replace the server in the rack, replace cables, and then fully power on the server by pressing the Power button.

**Figure 41: PCIe Riser Card Securing Mechanisms**



1	Release latch on hinged securing plate	3	Hinged card-tab retainer
2	Hinged securing plate	-	

## Cisco Virtual Interface Card (VIC) Considerations

This section describes VIC card support and special considerations for this server.



**Note** If you use the *Cisco Card* NIC mode, you must also make a *VIC Slot* setting that matches where your VIC is installed. The options are Riser1, Riser2, and mLOM. See [NIC Mode and NIC Redundancy Settings](#), on page 22 for more information about NIC modes.

**Table 14: VIC Support and Considerations in This Server**

VIC	How Many Supported in Server	Slots That Support VICs	Primary Slot For <i>Cisco Card</i> NIC Mode	Minimum Cisco IMC Firmware
Cisco UCS VIC 1467 UCSC-M-V25-04	1 mLOM	mLOM	mLOM	4.2(1)
Cisco UCS VIC 1477 UCSC-M-V100-04	1 mLOM	mLOM	mLOM	4.2(1)
Cisco UCS VIC 1455 UCSC-PCIE-C25Q-04	2 PCIe	Riser 1 PCIe slot 1 and 2 Riser 2 PCIe slot 4 and 5	Riser 1 PCIe slot 2 Riser 2 PCIe slot 5 <b>Note</b> Cisco PCIe VICs can be installed in slots 1 and 4 if GPUs are installed in slots 2 and 5.	4.2(1)

Cisco UCS VIC 1495 UCSC-PCIE-C100-04	2 PCIe	Riser 1 PCIe slot 1 and 2  Riser 2 PCIe slot 4 and 5	Riser 1 PCIe slot 2 Riser 2 PCIe slot 5  <b>Note</b> Cisco PCIe VICs can be installed in slots 1 and 4 if GPUs are installed in slots 2 and 5.	4.2(1)
---	--------	--	---	--------

- If the server does not have any VIC card, the default NIC mode is set to **Dedicated mode** and NIC redundancy is set to **None**. If the server has a VIC card, the NIC mode is set to **Cisco Card mode** and the NIC redundancy is set to **Active-Active**.

VIC precedence first goes to MLOM, then Riser 1 and then Riser 2.

- A total of 3 VICs are supported in the server: Two PCIe slots and one mLOM slot.



**Note** Single wire management is supported on only one VIC at a time. If multiple VICs are installed on a server, only one slot has NCSI enabled at a time. For single wire management, priority goes to the MLOM slot, then slot 2, then slot 5 for NCSI management traffic. When multiple cards are installed, connect the single-wire management cables in the priority order mentioned above.

- The primary slot for a VIC card in PCIe riser 1 is slot 2. The secondary slot for a VIC card in PCIe riser 1 is slot 1.



**Note** The NCSI protocol is supported in only one slot at a time in each riser. If a GPU card is present in slot 2, NCSI automatically shifts from slot 2 to slot 1.

- The primary slot for a VIC card in PCIe Riser 2 is slot 5. The secondary slot for a VIC card in PCIe riser 2 is slot 4.



**Note** The NCSI protocol is supported in only one slot at a time in each riser. If a GPU card is present in slot 5, NCSI automatically shifts from slot 5 to slot 4.



**Note** PCIe riser 2 is not available in a single-CPU system.

- In a single CPU configuration, only a single plug-in PCIe VIC card may be installed in slots 1, 2, or 3 of riser 1.

## Replacing an mLOM Card

The server supports a modular LOM (mLOM) card to provide additional rear-panel connectivity. The mLOM socket is on the motherboard, under PCIe Riser 1.

The mLOM socket provides a Gen-3 and Gen-4 x16 PCIe lane. The socket remains powered when the server is in 12 V standby power mode and it supports the network communications services interface (NCSI) protocol.



---

**Note** If your mLOM card is a Cisco UCS Virtual Interface Card (VIC), see [Cisco Virtual Interface Card \(VIC\) Considerations, on page 90](#) for more information and support details.

---

**Step 1** Remove any existing mLOM card (or a blanking panel):

- a) Shut down and remove power from the server as described in [Shutting Down and Removing Power From the Server, on page 34](#).
- b) Slide the server out the front of the rack far enough so that you can remove the top cover. You might have to detach cables from the rear panel to provide clearance.

**Caution** If you cannot safely view and access the component, remove the server from the rack.

- c) Remove the top cover from the server as described in [Removing the Server Top Cover, on page 35](#).
- d) Remove PCIe Riser 1 to provide clearance to the mLOM socket on the motherboard. See [Replacing a PCIe Riser, on page 77](#).
- e) Loosen the single captive thumbscrew that secures the mLOM card to the threaded standoff on the chassis floor.
- f) Slide the mLOM card horizontally to free it from the socket, then lift it out of the server.

**Step 2** Install a new mLOM card:

- a) Set the mLOM card on the chassis floor so that its connector is aligned with the motherboard socket.
- b) Push the card horizontally to fully engage the card's edge connector with the socket.
- c) Tighten the captive thumbscrew to secure the card to the chassis floor.
- d) Return the storage controller card to the server. See [Replacing a SAS Storage Controller Card \(RAID or HBA\), on page 92](#).
- e) Replace the top cover to the server.
- f) Replace the server in the rack, replace cables, and then fully power on the server by pressing the Power button.

## Replacing a SAS Storage Controller Card (RAID or HBA)

For hardware-based storage control, the server can use a Cisco modular SAS RAID controller or SAS HBA that plugs into a dedicated, vertical socket on the motherboard.



## Storage Controller Card Firmware Compatibility

Firmware on the storage controller (RAID or HBA) must be verified for compatibility with the current Cisco IMC and BIOS versions that are installed on the server. If not compatible, upgrade or downgrade the storage controller firmware using the Host Upgrade Utility (HUU) for your firmware release to bring it to a compatible level.



**Note** **For servers running in standalone mode only:** After you replace controller hardware (UCSC-RAID-M6HD and UCSC-SAS-M6HD), you must run the Cisco UCS Host Upgrade Utility (HUU) to update the controller firmware, even if the firmware Current Version is the same as the Update Version. This is necessary to program the controller's suboem-id to the correct value for the server SKU. If you do not do this, drive enumeration might not display correctly in the software.

See the HUU guide for your Cisco IMC release for instructions on downloading and using the utility to bring server components to compatible levels: [HUU Guides](#).

## Replacing a SAS Storage Controller Card (RAID or HBA)

The chassis includes a plastic mounting bracket that the card must be attached to before installation.

**Step 1** Prepare the server for component installation:

- Shut down and remove power from the server as described in [Shutting Down and Removing Power From the Server, on page 34](#).
- Slide the server out the front of the rack far enough so that you can remove the top cover. You might have to detach cables from the rear panel to provide clearance.

**Caution** If you cannot safely view and access the component, remove the server from the rack.

- Remove the top cover from the server as described in [Removing the Server Top Cover, on page 35](#).

**Step 2** Remove any existing storage controller card from the server:

**Note** The chassis includes a plastic mounting bracket that the card must be attached to before installation. During replacement, you must remove the old card from the bracket and then install the new card to the bracket before installing this assembly to the server.

- Disconnect SAS/SATA cables and any Supercap cable from the existing card.
- Lift up on the card's blue ejector lever to unseat it from the motherboard socket.
- Lift straight up on the card's carrier frame to disengage the card from the motherboard socket and to disengage the frame from two pegs on the chassis wall.
- Remove the existing card from its plastic carrier bracket. Carefully push the retainer tabs aside and then lift the card from the bracket.

**Step 3** Install a new storage controller card:

- Install the new card to the plastic carrier bracket. Make sure that the retainer tabs close over the edges of the card.
- Position the assembly over the chassis and align the card edge with the motherboard socket. At the same time, align the two slots on the back of the carrier bracket with the pegs on the chassis inner wall.
- Push on both corners of the card to seat its connector in the riser socket. At the same time, ensure that the slots on the carrier frame engage with the pegs on the inner chassis wall.

- d) Fully close the blue ejector lever on the card to lock the card into the socket.
- e) Connect SAS/SATA cables and any Supercap cable to the new card.

If this is a first-time installation, see [Storage Controller Cable Connectors and Backplanes, on page 137](#) for cabling instructions.

**Step 4** Replace the top cover to the server.

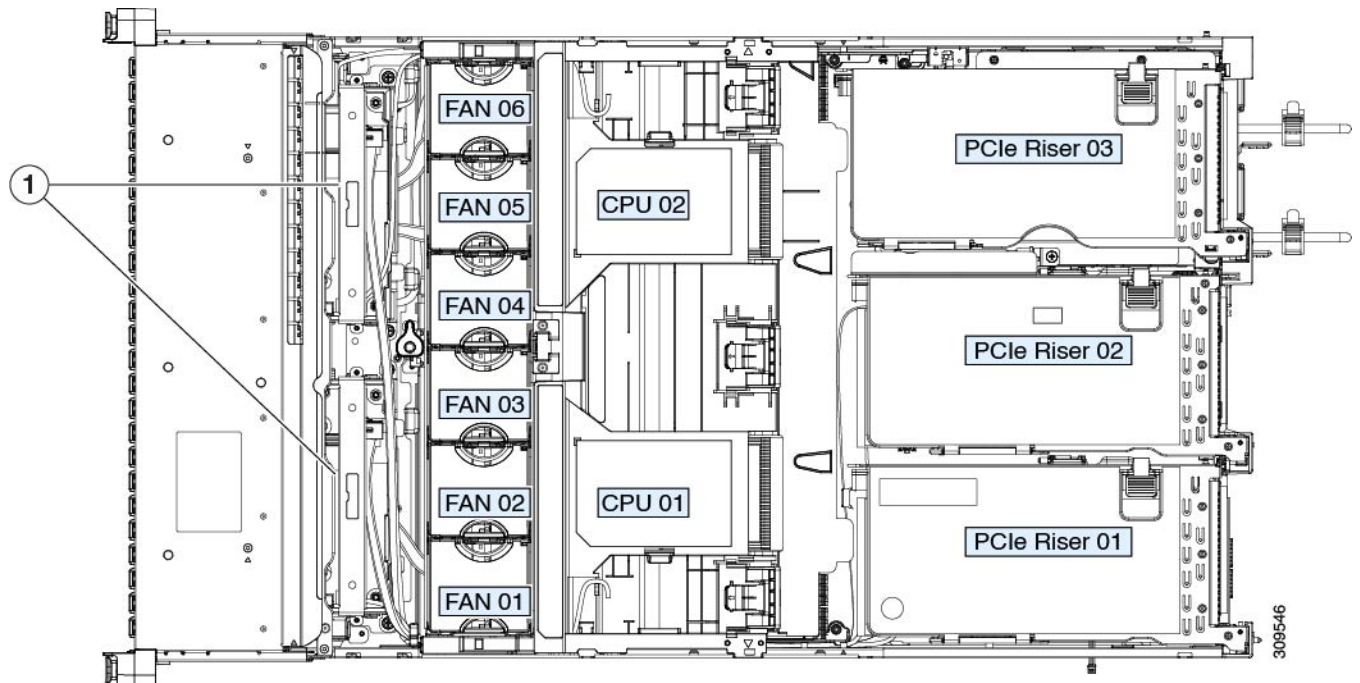
**Step 5** Replace the server in the rack, replace cables, and then fully power on the server by pressing the Power button.

**Step 6** If your server is running in standalone mode, use the Cisco UCS Host Upgrade Utility to update the controller firmware and program the correct suboem-id for the controller.

**Note** **For servers running in standalone mode only:** After you replace controller hardware (UCSC-RAID-M6HD and UCSC-SAS-M6HD), you must run the Cisco UCS Host Upgrade Utility (HUU) to update the controller firmware, even if the firmware Current Version is the same as the Update Version. This is necessary to program the controller's suboem-id to the correct value for the server SKU. If you do not do this, drive enumeration might not display correctly in the software. This issue does not affect servers controlled in UCSM mode.

See the HUU guide for your Cisco IMC release for instructions on downloading and using the utility to bring server components to compatible levels: [HUU Guides](#).

**Figure 42: Replacing a Storage Controller Card**



1	Blue ejector lever on card top edge	2	Pegs on inner chassis wall (two)
---	-------------------------------------	---	----------------------------------

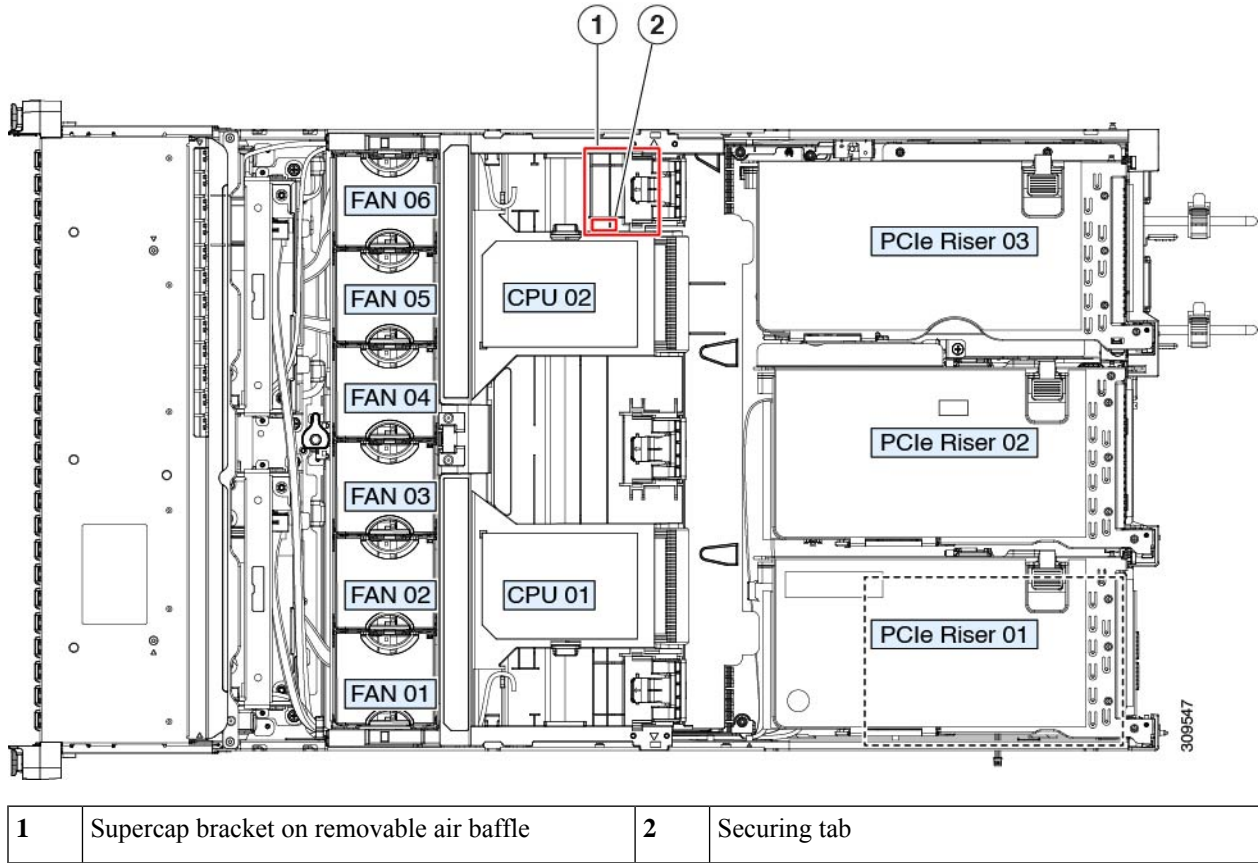
# Replacing the Supercap (RAID Backup)

This server supports installation of one Supercap unit. The unit mounts to a bracket on the removable air baffle.

The Supercap provides approximately three years of backup for the disk write-back cache DRAM in the case of a sudden power loss by offloading the cache to the NAND flash.

- 
- Step 1** Prepare the server for component installation:
- Shut down and remove power from the server as described in [Shutting Down and Removing Power From the Server, on page 34](#).
  - Slide the server out the front of the rack far enough so that you can remove the top cover. You might have to detach cables from the rear panel to provide clearance.  
**Caution** If you cannot safely view and access the component, remove the server from the rack.
  - Remove the top cover from the server as described in [Removing the Server Top Cover, on page 35](#).
- Step 2** Remove an existing Supercap:
- Disconnect the Supercap cable from the existing Supercap.
  - Push aside the securing tab that holds the Supercap to its bracket on the air baffle.
  - Lift the Supercap free of the bracket and set it aside.
- Step 3** Install a new Supercap:
- Set the new Supercap into the mounting bracket.
  - Push aside the black plastic tab on the air baffle and set the Supercap into the bracket. Relax the tab so that it closes over the top edge of the Supercap.
  - Connect the Supercap cable from the RAID controller card to the connector on the Supercap cable.
- Step 4** Replace the top cover to the server.
- Step 5** Replace the server in the rack, replace cables, and then fully power on the server by pressing the Power button.

Figure 43: Supercap Bracket on Air Baffle



## Replacing a Boot-Optimized M.2 RAID Controller Module

The Cisco Boot-Optimized M.2 RAID Controller module connects to the mini-storage module socket on the motherboard. It includes slots for two SATA M.2 drives that can control the SATA M.2 drives in a RAID 1 array and JBOD mode.

### Cisco Boot-Optimized M.2 RAID Controller Considerations

Review the following considerations:



**Note** The Cisco Boot-Optimized M.2 RAID Controller is not supported when the server is used as a compute-only node in Cisco HyperFlex configurations.

- The minimum version of Cisco IMC that support this controller is 4.1(1) and later.
- This controller supports RAID 1 (single volume) and JBOD mode.



**Note** Do not use the server's embedded SW MegaRAID controller to configure RAID settings when using this controller module. Instead, you can use the following interfaces:

- Cisco IMC 4.1(1) and later
  - BIOS HII utility, BIOS 4.1(1) and later
- 
- A SATA M.2 drive in slot 1 (the top) is the first SATA device; a SATA M.2 drive in slot 2 (the underside) is the second SATA device.
    - The name of the controller in the software is UCS-M2-HWRAID.
    - A drive in Slot 1 is mapped as drive 253; a drive in slot 2 is mapped as drive 254.
  - When using RAID, we recommend that both SATA M.2 drives are the same capacity. If different capacities are used, the smaller capacity of the two drives is used to create a volume and the rest of the drive space is unusable.
  - Hot-plug replacement is *not* supported. The server must be powered off.
  - Monitoring of the controller and installed SATA M.2 drives can be done using Cisco IMC. They can also be monitored using other utilities such as UEFI HII, PMCLI, XMLAPI, and Redfish.
  - Updating firmware of the controller and the individual drives:
    - For standalone servers, use the Cisco Host Upgrade Utility (HUU). Refer to the [HUU Documentation](#).
  - The SATA M.2 drives can boot in UEFI mode only. Legacy boot mode is not supported.
  - If you replace a single SATA M.2 drive that was part of a RAID volume, rebuild of the volume is auto-initiated after the user accepts the prompt to import the configuration. If you replace both drives of a volume, you must create a RAID volume and manually reinstall any OS.
  - We recommend that you erase drive contents before creating volumes on used drives from another server. The configuration utility in the server BIOS includes a SATA secure-erase function.
  - The server BIOS includes a configuration utility specific to this controller that you can use to create and delete RAID volumes, view controller properties, and erase the physical drive contents. Access the utility by pressing **F2** when prompted during server boot. Then navigate to **Advanced > Cisco Boot Optimized M.2 RAID Controller**.

## Replacing a Cisco Boot-Optimized M.2 RAID Controller

This topic describes how to remove and replace a Cisco Boot-Optimized M.2 RAID Controller. The controller board has one M.2 socket on its top (Slot 1) and one M.2 socket on its underside (Slot 2).

- Step 1** Shut down and remove power from the server as described in [Shutting Down and Removing Power From the Server](#), on page 34.

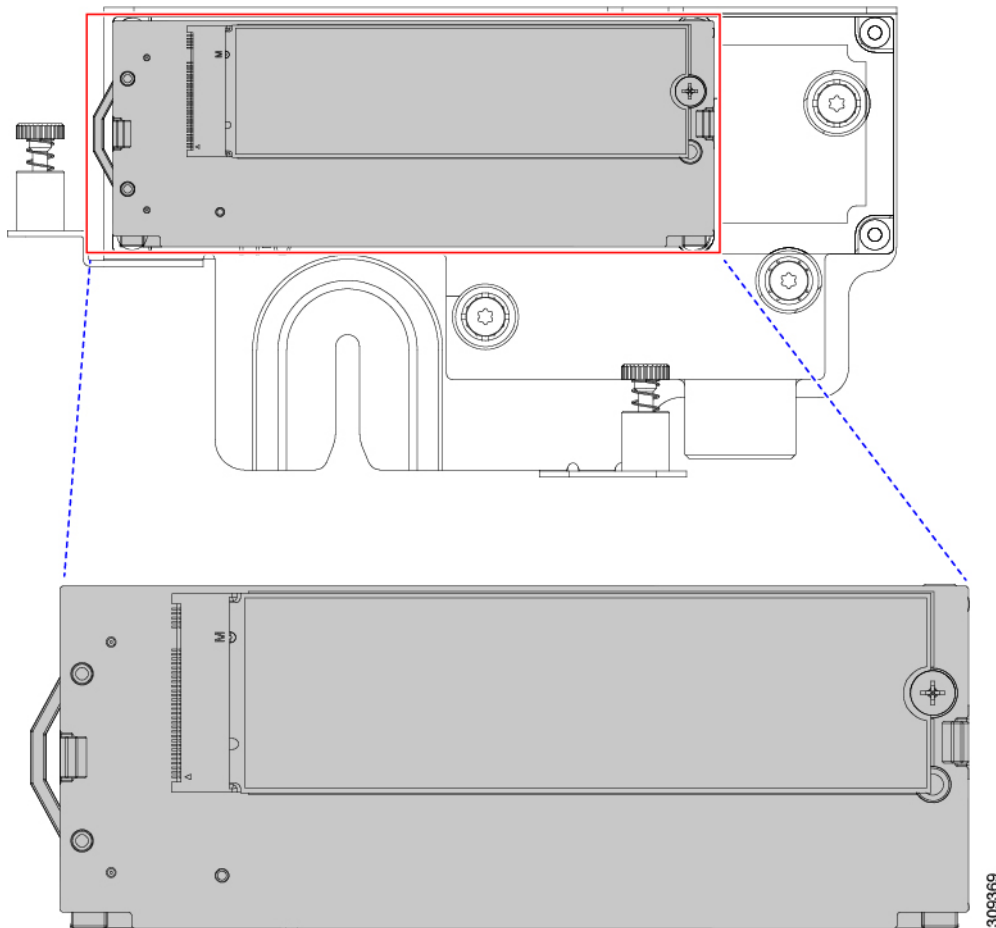
**Step 2** Slide the server out the front of the rack far enough so that you can remove the top cover. You might have to detach cables from the rear panel to provide clearance.

**Caution** If you cannot safely view and access the component, remove the server from the rack.

**Step 3** Remove the top cover from the server as described in [Removing the Server Top Cover](#), on page 35.

**Step 4** Remove a controller from its motherboard socket:

- a) Locate the controller in its socket between PCIe Riser 2 and 3.
- b) Using a #2 Phillips screwdriver, loosen the captive screws and remove the M.2 module.
- c) At each end of the controller board, push outward on the clip that secures the carrier.
- d) Lift both ends of the controller to disengage it from the carrier.



- e) Set the carrier on an anti-static surface.

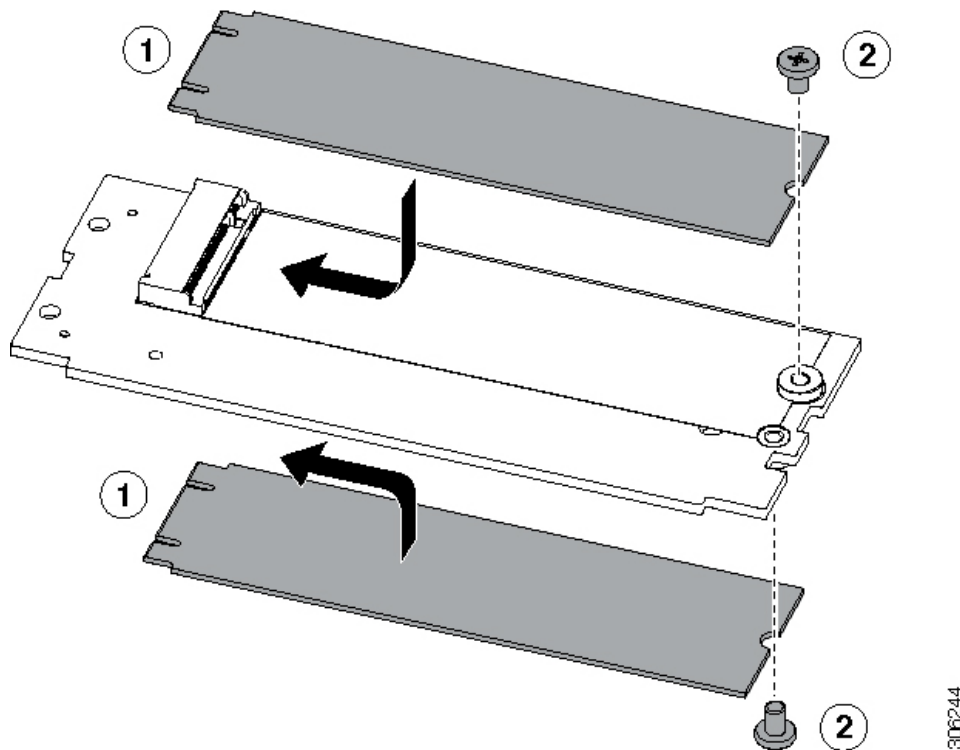
**Step 5** If you are transferring SATA M.2 drives from the old controller to the replacement controller, do that before installing the replacement controller:

**Note** Any previously configured volume and data on the drives are preserved when the M.2 drives are transferred to the new controller. The system will boot the existing OS that is installed on the drives.

- a) Use a #1 Phillips-head screwdriver to remove the single screw that secures the M.2 drive to the carrier.
- b) Lift the M.2 drive from its socket on the carrier.

- c) Position the replacement M.2 drive over the socket on the controller board.
- d) Angle the M.2 drive downward and insert the connector-end into the socket on the carrier. The M.2 drive's label must face up.
- e) Press the M.2 drive flat against the carrier.
- f) Install the single screw that secures the end of the M.2 SSD to the carrier.
- g) Turn the controller over and install the second M.2 drive.

**Figure 44: Cisco Boot-Optimized M.2 RAID Controller, Showing M.2 Drive Installation**



**Step 6** Install the controller to its socket on the motherboard:

- a) Position the controller over the socket, with the controller's connector facing down and at the same end as the motherboard socket. Two alignment pegs must match with two holes on the controller.
- b) Gently push down the socket end of the controller so that the two pegs go through the two holes on the controller.
- c) Push down on the controller so that the securing clips click over it at both ends.

**Step 7** Replace the top cover to the server.

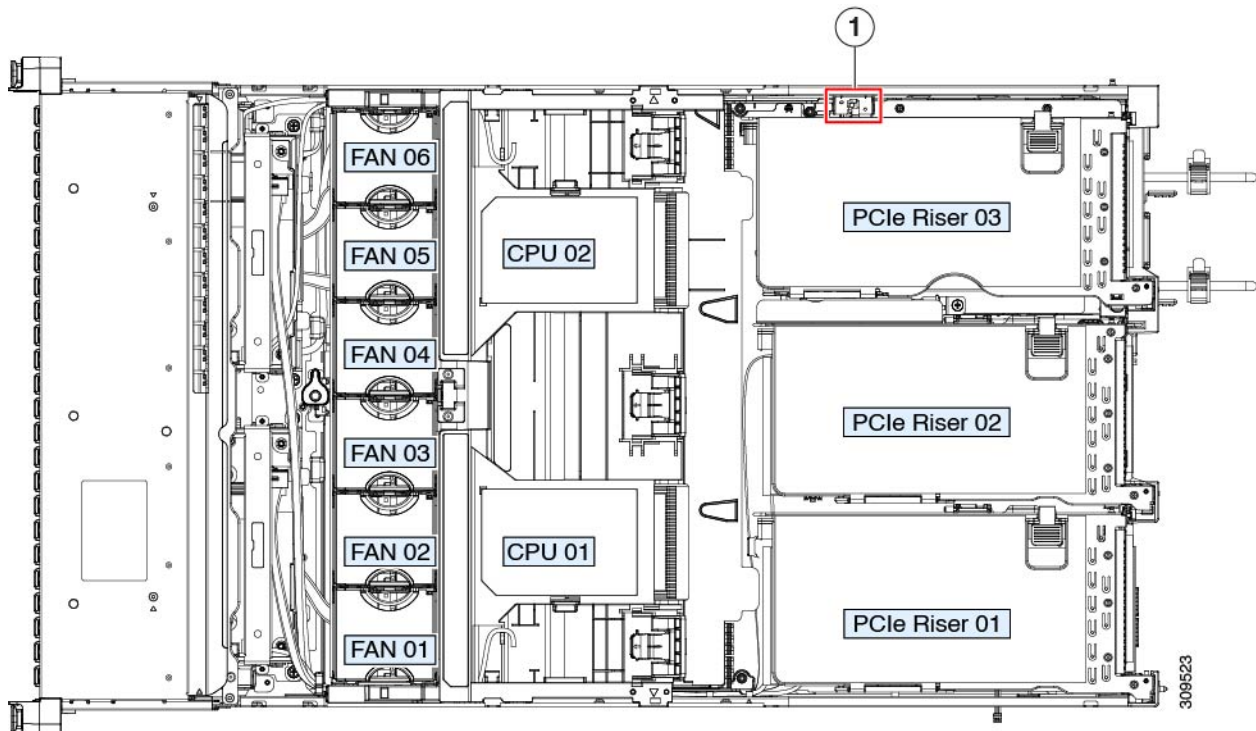
**Step 8** Replace the server in the rack, replace cables, and then fully power on the server by pressing the Power button.

## Replacing a Chassis Intrusion Switch

The chassis intrusion switch is an optional security feature that logs an event in the system event log (SEL) whenever the cover is removed from the chassis.

- Step 1** Prepare the server for component installation:
- Shut down and remove power from the server as described in [Shutting Down and Removing Power From the Server, on page 34](#).
  - Slide the server out the front of the rack far enough so that you can remove the top cover. You might have to detach cables from the rear panel to provide clearance.
- Caution** If you cannot safely view and access the component, remove the server from the rack.
- Remove the top cover from the server as described in [Removing the Server Top Cover, on page 35](#).
- Step 2** Remove an existing intrusion switch:
- Disconnect the intrusion switch cable from the socket on the motherboard.
  - Use a #1 Phillips-head screwdriver to loosen and remove the single screw that holds the switch mechanism to the chassis wall.
  - Slide the switch mechanism straight up to disengage it from the clips on the chassis.
- Step 3** Install a new intrusion switch:
- Slide the switch mechanism down into the clips on the chassis wall so that the screw holes line up.
  - Use a #1 Phillips-head screwdriver to install the single screw that secures the switch mechanism to the chassis wall.
  - Connect the switch cable to the socket on the motherboard.
- Step 4** Replace the cover to the server.
- Step 5** Replace the server in the rack, replace cables, and then fully power on the server by pressing the Power button.

**Figure 45: Replacing a Chassis Intrusion Switch**





1	Intrusion switch location	-	
---	---------------------------	---	--

## Installing a Trusted Platform Module (TPM)

The trusted platform module (TPM) is a small circuit board that plugs into a motherboard socket and is then permanently secured with a one-way screw. The socket location is on the motherboard below PCIe riser 2.

### TPM Considerations

- This server supports either TPM version 1.2 or TPM version 2.0.
- Field replacement of a TPM is not supported; you can install a TPM after-factory only if the server does not already have a TPM installed.
- If there is an existing TPM 1.2 installed in the server, you cannot upgrade to TPM 2.0. If there is no existing TPM in the server, you can install TPM 2.0.
- If the TPM 2.0 becomes unresponsive, reboot the server.

### Installing and Enabling a TPM



**Note** Field replacement of a TPM is not supported; you can install a TPM after-factory only if the server does not already have a TPM installed.

This topic contains the following procedures, which must be followed in this order when installing and enabling a TPM:

1. Installing the TPM Hardware
2. Enabling the TPM in the BIOS
3. Enabling the Intel TXT Feature in the BIOS

### Installing TPM Hardware



**Note** For security purposes, the TPM is installed with a one-way screw. It cannot be removed with a standard screwdriver.

**Step 1** Prepare the server for component installation:

- a) Shut down and remove power from the server as described in [Shutting Down and Removing Power From the Server, on page 34](#).

- b) Slide the server out the front of the rack far enough so that you can remove the top cover. You might have to detach cables from the rear panel to provide clearance.

**Caution** If you cannot safely view and access the component, remove the server from the rack.

- c) Remove the top cover from the server as described in [Removing the Server Top Cover, on page 35](#).

**Step 2** Remove PCIe riser 2 from the server to provide clearance to the TPM socket on the motherboard.

**Step 3** Install a TPM:

- a) Locate the TPM socket on the motherboard.
- b) Align the connector that is on the bottom of the TPM circuit board with the motherboard TPM socket. Align the screw hole on the TPM board with the screw hole that is adjacent to the TPM socket.
- c) Push down evenly on the TPM to seat it in the motherboard socket.
- d) Install the single one-way screw that secures the TPM to the motherboard.

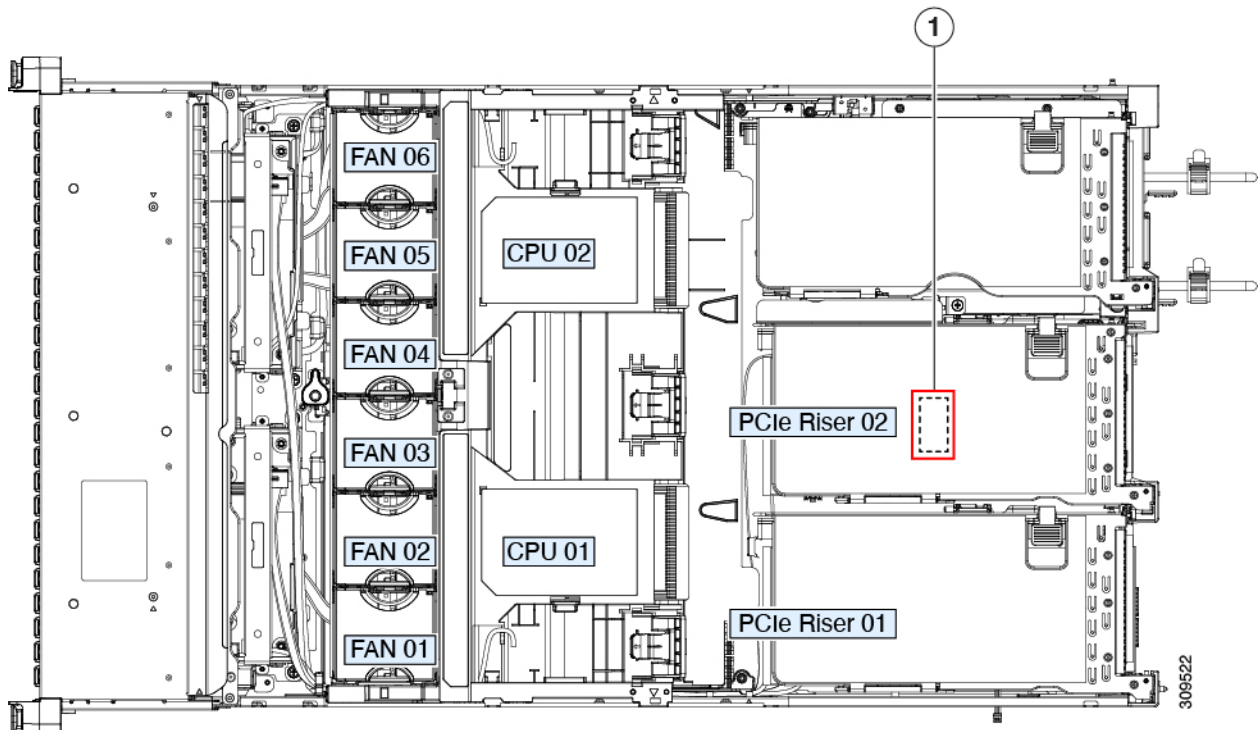
**Step 4** Replace PCIe riser 2 to the server. See [Replacing a PCIe Riser, on page 77](#).

**Step 5** Replace the cover to the server.

**Step 6** Replace the server in the rack, replace cables, and then fully power on the server by pressing the Power button.

**Step 7** Continue with [Enabling the TPM in the BIOS, on page 103](#).

**Figure 46: Location of the TPM Socket**



1	TPM socket location on motherboard, below PCIe riser 2	
---	--	--

## Enabling the TPM in the BIOS

After hardware installation, you must enable TPM support in the BIOS.



**Note** You must set a BIOS Administrator password before performing this procedure. To set this password, press the **F2** key when prompted during system boot to enter the BIOS Setup utility. Then navigate to **Security > Set Administrator Password** and enter the new password twice as prompted.

### Step 1

Enable TPM Support:

- a) Watch during bootup for the F2 prompt, and then press **F2** to enter BIOS setup.
- b) Log in to the BIOS Setup Utility with your BIOS Administrator password.
- c) On the BIOS Setup Utility window, choose the **Advanced** tab.
- d) Choose **Trusted Computing** to open the TPM Security Device Configuration window.
- e) Change TPM SUPPORT to **Enabled**.
- f) Press **F10** to save your settings and reboot the server.

### Step 2

Verify that TPM support is now enabled:

- a) Watch during bootup for the F2 prompt, and then press **F2** to enter BIOS setup.
- b) Log into the BIOS Setup utility with your BIOS Administrator password.
- c) Choose the **Advanced** tab.
- d) Choose **Trusted Computing** to open the TPM Security Device Configuration window.
- e) Verify that TPM SUPPORT and TPM State are Enabled.

## Removing the PCB Assembly (PCBA)

The PCBA is secured to the server's sheet metal. You must disconnect the PCBA from the tray before recycling the PCBA. The PCBA is secured by different types of fasteners.

### Before you begin



**Note For Recyclers Only!** This procedure is not a standard field-service option. This procedure is for recyclers who will be reclaiming the electronics for proper disposal to comply with local eco design and e-waste regulations.

To remove the printed circuit board assembly (PCBA), the following requirements must be met:

- The server must be disconnected from facility power.
- The server must be removed from the equipment rack.
- The server's top cover must be removed. See [Removing the Server Top Cover, on page 35](#).

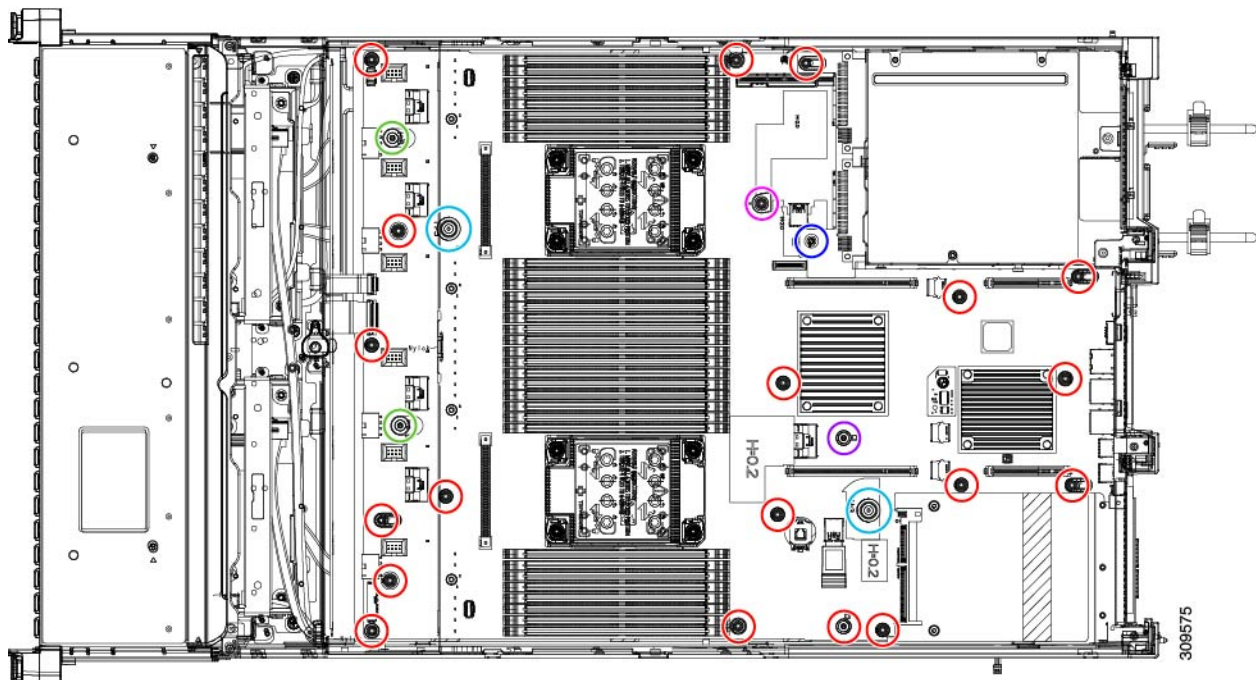
Following tools are required:

- Pliers
- T10 Torx screwdriver
- #2 Phillips screwdriver

**Step 1** Locate the PCBA's mounting screws.

The following figure shows the location of the mounting screws and fasteners.

**Figure 47: Screw Locations for Removing the UCS C245 M6 PCBA**



- Torx T10 - Torque : 10.0 kgf-cm (8.68 in-lbs)
- Torx T10 - Torque : 5.0 kgf-cm (4.34 in-lbs)
- Special fixture - Torque : 10.0 kgf-cm (8.68 in-lbs)
- Special fixture - Torque : 10.0 kgf-cm (8.68 in-lbs)
- #2 PILLIPS (On PSU air duct) - Torque : 5.0 kgf-cm (4.34 in-lbs)
- #2 PILLIPS (On M.2 riser cage) - Torque : 5.0 kgf-cm (4.34 in-lbs)

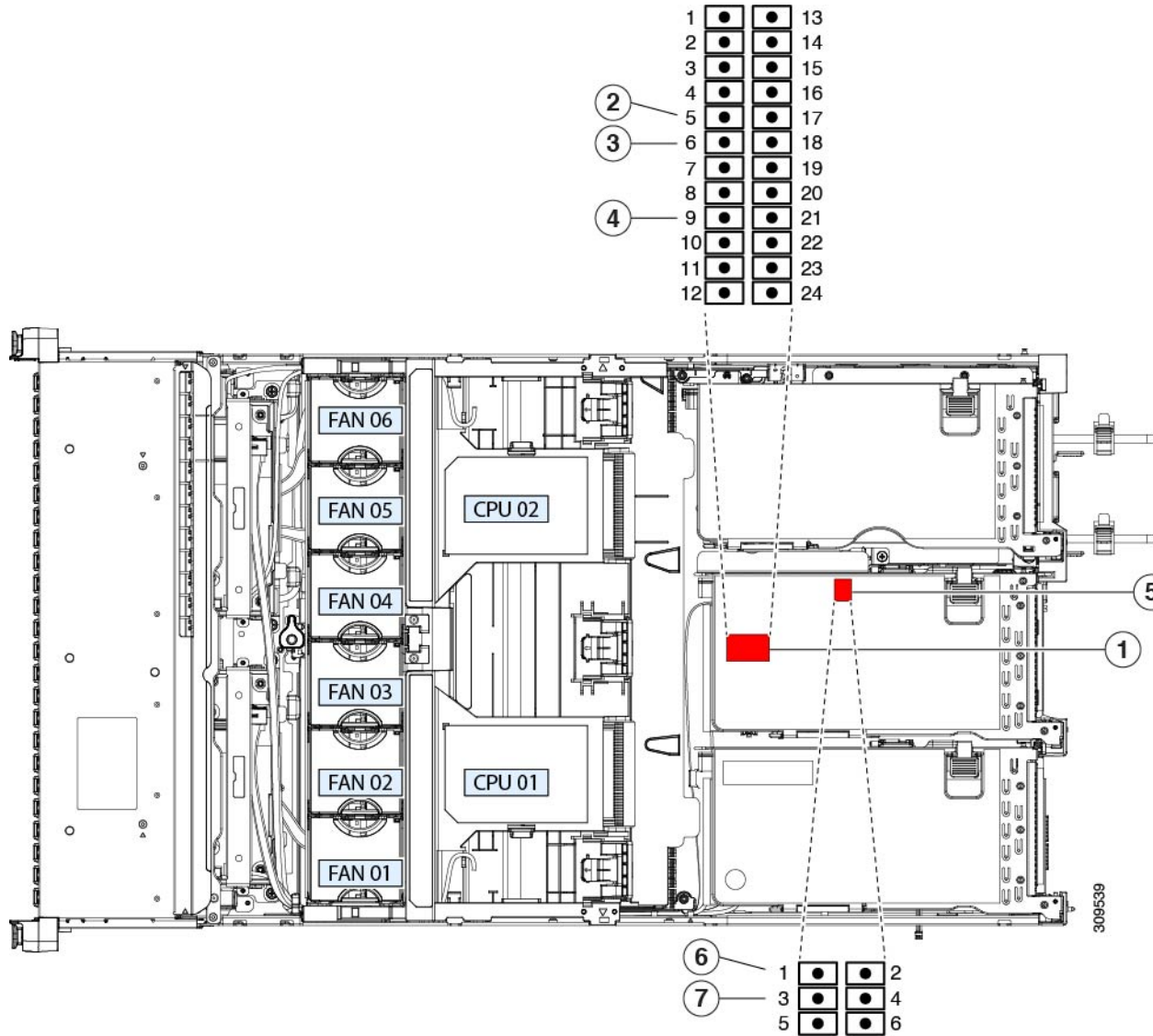
**Step 2** Using the appropriate tools, remove the screws.

**Step 3** Remove the PCBA from the sheetmetal and dispose of each in compliance with your local ewaste and recycling regulations.

# Service Headers and Jumpers

This server includes two blocks of headers (SW4, CN4) that you can jumper for certain service and debug functions.

Figure 48: Location of Service Header Blocks SW4 and CN4



309539

<p><b>1</b> Location of header block SW4</p>	<p><b>5</b> Location of header block CN4</p>
<p><b>2</b> Recover BIOS: SW4 pins 5 - 17 off: Normal; ON: recovery mode</p>	<p><b>6</b> Boot Cisco IMC from alternate image: CN4 pins 1 - 2</p>
<p><b>3</b> Clear BIOS password: SW4 pins 6 - 18 off: normal; ON: clear</p>	<p><b>7</b> System Firmware Secure Erase: CN4 pins 3 - 4</p>

4	Clear CMOS: SW pins 9 - 21 Off: normal; ON: clear		
---	--	--	--

## Using the BIOS Recovery Header (SW4, Pins 5 - 17)

Depending on which stage the BIOS becomes corrupted, you might see different behavior.

- If the BIOS BootBlock is corrupted, you might see the system get stuck on the following message:

```
Initializing and configuring memory/hardware
```

- If it is a non-BootBlock corruption, a message similar to the following is displayed:

```
****BIOS FLASH IMAGE CORRUPTED****
Flash a valid BIOS capsule file using Cisco IMC WebGUI or CLI interface.
IF Cisco IMC INTERFACE IS NOT AVAILABLE, FOLLOW THE STEPS MENTIONED BELOW.
1. Connect the USB stick with bios.cap file in root folder.
2. Reset the host.
IF THESE STEPS DO NOT RECOVER THE BIOS
1. Power off the system.
2. Mount recovery jumper.
3. Connect the USB stick with bios.cap file in root folder.
4. Power on the system.
Wait for a few seconds if already plugged in the USB stick.
REFER TO SYSTEM MANUAL FOR ANY ISSUES.
```




---

**Note** As indicated by the message shown above, there are two procedures for recovering the BIOS. Try procedure 1 first. If that procedure does not recover the BIOS, use procedure 2.

---

### Procedure 1: Reboot With bios.cap Recovery File

**Step 1** Download the BIOS update package and extract it to a temporary location.

**Step 2** Copy the contents of the extracted recovery folder to the root directory of a USB drive. The recovery folder contains the bios.cap file that is required in this procedure.

**Note** The bios.cap file must be in the root directory of the USB drive. Do not rename this file. The USB drive must be formatted with either the FAT16 or FAT32 file system.

**Step 3** Insert the USB drive into a USB port on the server.

**Step 4** Reboot the server.

**Step 5** Return the server to main power mode by pressing the Power button on the front panel.

The server boots with the updated BIOS boot block. When the BIOS detects a valid bios.cap file on the USB drive, it displays this message:

```
Found a valid recovery file...Transferring to Cisco IMC
System would flash the BIOS image now...
System would restart with recovered image after a few seconds...
```

**Step 6** Wait for server to complete the BIOS update, and then remove the USB drive from the server.

**Note** During the BIOS update, Cisco IMC shuts down the server and the screen goes blank for about 10 minutes. Do not unplug the power cords during this update. Cisco IMC powers on the server after the update is complete.

---

## Procedure 2: Use BIOS Recovery Header and bios.cap File

---

**Step 1** Download the BIOS update package and extract it to a temporary location.

**Step 2** Copy the contents of the extracted recovery folder to the root directory of a USB drive. The recovery folder contains the bios.cap file that is required in this procedure.

**Note** The bios.cap file must be in the root directory of the USB drive. Do not rename this file. The USB drive must be formatted with either the FAT16 or FAT32 file system.

**Step 3** Shut down and remove power from the server as described in [Shutting Down and Removing Power From the Server, on page 34](#). Disconnect power cords from all power supplies.

**Step 4** Slide the server out the front of the rack far enough so that you can remove the top cover. You might have to detach cables from the rear panel to provide clearance.

**Caution** If you cannot safely view and access the component, remove the server from the rack.

**Step 5** Remove the top cover from the server as described in [Removing the Server Top Cover, on page 35](#).

**Step 6** Install a two-pin jumper across SW4 pins 5 and 17.

**Step 7** Reconnect AC power cords to the server. The server powers up to standby power mode.

**Step 8** Insert the USB thumb drive that you prepared in Step 2 into a USB port on the server.

**Step 9** Return the server to main power mode by pressing the Power button on the front panel.

The server boots with the updated BIOS boot block. When the BIOS detects a valid bios.cap file on the USB drive, it displays this message:

```
Found a valid recovery file...Transferring to Cisco IMC
System would flash the BIOS image now...
System would restart with recovered image after a few seconds...
```

**Step 10** Wait for server to complete the BIOS update, and then remove the USB drive from the server.

**Note** During the BIOS update, Cisco IMC shuts down the server and the screen goes blank for about 10 minutes. Do not unplug the power cords during this update. Cisco IMC powers on the server after the update is complete.

**Step 11** After the server has fully booted, power off the server again and disconnect all power cords.

**Step 12** Remove the jumper that you installed.

**Note** If you do not remove the jumper, after recovery completion you see the prompt, "Please remove the recovery jumper."

**Step 13** Replace the top cover, replace the server in the rack, replace power cords and any other cables, and then power on the server by pressing the Power button.

---

## Using the Clear BIOS Password Header (SW4, Pins 6 - 18)

You can use this switch to clear the administrator password.

- 
- Step 1** Shut down and remove power from the server as described in [Shutting Down and Removing Power From the Server, on page 34](#). Disconnect power cords from all power supplies.
- Step 2** Slide the server out the front of the rack far enough so that you can remove the top cover. You might have to detach cables from the rear panel to provide clearance.
- Caution** If you cannot safely view and access the component, remove the server from the rack.
- Step 3** Remove the top cover from the server as described in [Removing the Server Top Cover, on page 35](#).
- Step 4** Install a two-pin jumper across SW4 pins 6 and 18.
- Step 5** Reinstall the top cover and reconnect AC power cords to the server. The server powers up to standby power mode, indicated when the Power LED on the front panel is amber.
- Step 6** Return the server to main power mode by pressing the Power button on the front panel. The server is in main power mode when the Power LED is green.
- Note** You must allow the entire server to reboot to main power mode to complete the reset. The state of the jumper cannot be determined without the host CPU running.
- Step 7** Press the Power button to shut down the server to standby power mode, and then remove AC power cords from the server to remove all power.
- Step 8** Remove the top cover from the server.
- Step 9** Remove the jumper that you installed.
- Note** If you do not remove the jumper, the password is cleared every time you power-cycle the server.
- Step 10** Replace the top cover, replace the server in the rack, replace power cords and any other cables, and then power on the server by pressing the Power button.
- 

## Using the Clear CMOS Header (SW4, Pins 9 - 21)

You can use this switch to clear the server's CMOS settings in the case of a system hang. For example, if the server hangs because of incorrect settings and does not boot, use this jumper to invalidate the settings and reboot with defaults.




---

**Caution** Clearing the CMOS removes any customized settings and might result in data loss. Make a note of any necessary customized settings in the BIOS before you use this clear CMOS procedure.

---

- 
- Step 1** Shut down and remove power from the server as described in [Shutting Down and Removing Power From the Server, on page 34](#).
- Step 2** Slide the server out the front of the rack far enough so that you can remove the top cover. You might have to detach cables from the rear panel to provide clearance.
- Caution** If you cannot safely view and access the component, remove the server from the rack.



- Step 3** Remove the top cover from the server as described in [Removing the Server Top Cover, on page 35](#).
- Step 4** To clear the CMOS, SW4, Pins 9-21 need to be in **ON** position for 5-10 seconds and reverted to **OFF** position.
- Step 5** Reinstall the top cover and reconnect AC power cords to the server. The server powers up to standby power mode, indicated when the Power LED on the front panel is amber.
- Step 6** Return the server to main power mode by pressing the Power button on the front panel. The server is in main power mode when the Power LED is green.
- Note** You must allow the entire server to reboot to main power mode to complete the reset. The state of the jumper cannot be determined without the host CPU running.
- Step 7** Press the Power button to shut down the server to standby power mode, and then remove AC power cords from the server to remove all power.
- 

## Using the Boot Alternate Cisco IMC Image Header (CN4, Pins 1 - 2)

You can use this Cisco IMC debug header to force the system to boot from an alternate Cisco IMC image.

---

- Step 1** Shut down and remove power from the server as described in [Shutting Down and Removing Power From the Server, on page 34](#). Disconnect power cords from all power supplies.
- Step 2** Slide the server out the front of the rack far enough so that you can remove the top cover. You might have to detach cables from the rear panel to provide clearance.
- Caution** If you cannot safely view and access the component, remove the server from the rack.
- Step 3** Remove the top cover from the server as described in [Removing the Server Top Cover, on page 35](#).
- Step 4** Install a two-pin jumper across CN4 pins 1 and 2.
- Step 5** Reinstall the top cover and reconnect AC power cords to the server. The server powers up to standby power mode, indicated when the Power LED on the front panel is amber.
- Step 6** Return the server to main power mode by pressing the Power button on the front panel. The server is in main power mode when the Power LED is green.
- Note** When you next log in to Cisco IMC, you see a message similar to the following:
- ```
'Boot from alternate image' debug functionality is enabled.  
CIMC will boot from alternate image on next reboot or input power cycle.
```
- Note** If you do not remove the jumper, the server will boot from an alternate Cisco IMC image every time that you power cycle the server or reboot Cisco IMC.
- Step 7** To remove the jumper, press the Power button to shut down the server to standby power mode, and then remove AC power cords from the server to remove all power.
- Step 8** Remove the top cover from the server.
- Step 9** Remove the jumper that you installed.
- Step 10** Replace the top cover, replace the server in the rack, replace power cords and any other cables, and then power on the server by pressing the Power button.
-

## Using the System Firmware Secure Erase Header (CN4, Pins 3 - 4)

You can use this Cisco IMC debug header to force the Cisco IMC settings back to the defaults.

- 
- Step 1** Shut down and remove power from the server as described in [Shutting Down and Removing Power From the Server, on page 34](#). Disconnect power cords from all power supplies.
- Step 2** Slide the server out the front of the rack far enough so that you can remove the top cover. You might have to detach cables from the rear panel to provide clearance.
- Caution** If you cannot safely view and access the component, remove the server from the rack.
- Step 3** Remove the top cover from the server as described in [Removing the Server Top Cover, on page 35](#).
- Step 4** Install a two-pin jumper across CN4 pins 3 and 4.
- Step 5** Reinstall the top cover and reconnect AC power cords to the server. The server powers up to standby power mode, indicated when the Power LED on the front panel is amber.
- Step 6** Return the server to main power mode by pressing the Power button on the front panel. The server is in main power mode when the Power LED is green.
- Note** When you next log in to Cisco IMC, you see a message similar to the following:
- ```
'CIMC reset to factory defaults' debug functionality is enabled.  
On input power cycle, CIMC will be reset to factory defaults.
```
- Note** If you do not remove the jumper, the server will reset the Cisco IMC to the default settings every time that you power cycle the server. The jumper has no effect if you reboot Cisco IMC.
- Step 7** To remove the jumper, press the Power button to shut down the server to standby power mode, and then remove AC power cords from the server to remove all power.
- Step 8** Remove the top cover from the server.
- Step 9** Remove the jumper that you installed.
- Step 10** Replace the top cover, replace the server in the rack, replace power cords and any other cables, and then power on the server by pressing the Power button.
-



# APPENDIX **A**

## Server Specifications

- [Physical Specifications](#), on page 111
- [Environmental Specifications](#), on page 111
- [Power Specifications](#), on page 112
- [Power Cord Specifications](#), on page 117

## Physical Specifications

The following table lists the physical specifications for the server versions.

**Table 15: Physical Specifications**

Description	Specification
Height	3.42 in. (86.4 mm)
Width	16.9 in. (429.0 mm)
Depth (length)	Server only: 30 in. (740.3 mm) Server with slide rail: 31.5 in (787.4 mm)
Server weight	<ul style="list-style-type: none"><li>• Maximum, fully configured with rail kit: 61.7 lb. (28 kg)</li><li>• Minimum, empty chassis, no rail kit: 35.7 lb. (16.2 kg)</li></ul>

## Environmental Specifications

The following table lists the environmental requirements and specifications for the server.

**Table 16: Physical Specifications**

Description	Specification
-------------	---------------

Temperature, Operating	50 to 95°F (10 to 35°C) Extended environment 41 to 104°F (5 to 40°C) Derate the maximum temperature by 1°C per every 300 meters of altitude above sea level. <b>Note</b> Although the ASHRAE guidelines define multiple classes with different operating ranges, the <i>recommended</i> temperature and humidity operating range is the same for each class. The <i>recommended</i> temperature and humidity ranges are: <ul style="list-style-type: none"><li>• Operating Temperature: 64.4°F to 80.6°F (18°C to 27°C)</li></ul> For general information, see the <a href="#">Cisco Unified Computing System Site Planning Guide: Data Center Power and Cooling</a> .
Temperature, non-operating (when the server is stored or transported)	–40 to 149°F (–40 to 65°C)
Humidity (RH), operating	8 to 90%
Humidity (RH), non-operating (when the server is stored or transported)	5 to 95%
Altitude, operating	0 to 10,000 feet
Altitude, non-operating (when the server is stored or transported)	0 to 39370 feet
Sound power level Measure A-weighted per ISO7779 LwAd (Bels) Operation at 73°F (23°C)	5.8
Sound pressure level Measure A-weighted per ISO7779 LpAm (dBA) Operation at 73°F (23°C)	43

## Power Specifications



**Note** Do not mix power supply types or wattages in the server. Both power supplies must be identical.

You can get more specific power information for your exact server configuration by using the Cisco UCS Power Calculator:

<http://ucspowercalc.cisco.com>

The power specifications for the supported power supply options are listed in the following sections.

## 770 W AC Power Supply

This section lists the specifications for each 770 W AC power supply (Cisco part number UCSC-PSU1-770W).

**Table 17: 770 W AC Specifications**

Description	Specification
AC Input Voltage	Nominal range: 100–120 VAC, 200–240 VAC (Range: 90–132 VAC, 180–264 VAC)
AC Input Frequency	Nominal range: 50 to 60Hz (Range: 47–63 Hz)
Maximum AC Input current	9.5 A at 100 VAC 4.5 A at 208 VAC
Maximum input volt-amperes	950 VA at 100 VAC
Maximum inrush current	15 A (sub-cycle duration)
Maximum hold-up time	12 ms at 770 W
Maximum output power per PSU	770 W
Power supply output voltage	12 VDC
Power supply standby voltage	12 VDC
Efficiency rating	Climate Savers Platinum Efficiency (80Plus Platinum certified)
Form factor	RSP2
Input connector	IEC320 C14

## 1050 W AC Power Supply

This section lists the specifications for each 1050 W AC power supply (Cisco part number UCSC-PSU1-1050W).

**Table 18: 1050 W AC Specifications**

Description	Specification
AC Input Voltage	Nominal range: 100–120 VAC, 200–240 VAC (Range: 90–132 VAC, 180–264 VAC)

AC Input Frequency	Nominal range: 50 to 60Hz (Range: 47–63 Hz)
Maximum AC Input current	12.5 A at 100 VAC 6.0 A at 208 VAC
Maximum input volt-amperes	1250 VA at 100 VAC
Maximum inrush current	15 A (sub-cycle duration)
Maximum hold-up time	12 ms at 1050 W
Maximum output power per PSU	800 W at 100–120 VAC 1050 W at 200–240 VAC
Power supply output voltage	12 VDC
Power supply standby voltage	12 VDC
Efficiency rating	Climate Savers Platinum Efficiency (80Plus Platinum certified)
Form factor	RSP2
Input connector	IEC320 C14

## 1200 W AC Power Supply

This section lists the specifications for each 1050 W AC power supply (Cisco part number UCSC-PSU1-1200W-D).

**Table 19: 1200 W AC Specifications**

Description	Specification
AC input voltage	Range: 100–230 VAC
AC input frequency	Range: 50 to 60Hz
Maximum AC input current	12.97 A at 100 VAC
Maximum input volt-amperes	1345 VA at 208 VAC
Maximum inrush current	20 A
Maximum hold-up time	12 ms at 1200 W
Maximum output power per PSU	1100 W at 100–120 VAC 1200 W at 208–230 VAC
Power supply output voltage	12 VDC
Power supply standby voltage	12 VDC

Efficiency rating	Climate Savers Platinum Efficiency (80Plus Titanium certified)
Form factor	RSP2
Input connector	IEC320 C14

## 1600 W AC Power Supply

This section lists the specifications for each 1600 W AC power supply (Cisco part number UCSC-PSU1-1600W).

**Table 20: 1600 W AC Specifications**

Description	Specification
AC Input Voltage	Nominal range: 200–240 VAC (Range: 180–264 VAC)
AC Input Frequency	Nominal range: 50 to 60Hz (Range: 47–63 Hz)
Maximum AC Input current	9.5 A at 200 VAC
Maximum input volt-amperes	1250 VA at 200 VAC
Maximum inrush current	30 A at 35° C
Maximum hold-up time	80 ms at 1600 W
Maximum output power per PSU	1600 W at 200–240 VAC
Power supply output voltage	12 VDC
Power supply standby voltage	12 VDC
Efficiency rating	Climate Savers Platinum Efficiency (80Plus Platinum certified)
Form factor	RSP2
Input connector	IEC320 C14

## 2300 W AC Power Supply

This section lists the specifications for each 2300 W AC power supply (Cisco part number UCSC-PSU1-2300).

**Table 21: 2300 W AC Specifications**

Description	Specification
-------------	---------------

AC Input Voltage	Nominal range: 100–230 VAC (Range: 90–264 VAC)
AC Input Frequency	Nominal range: 50 to 60Hz (Range: 47–63 Hz)
Maximum AC Input current	13 A at 100 VAC
Maximum input volt-amperes	2515 VA at 208 VAC
Maximum inrush current	30 A at 35° C
Maximum hold-up time	80 ms at 1600 W
Maximum output power per PSU	2300W at 220-240V input and 1200W at 110-120V
Power supply output voltage	12 VDC
Power supply standby voltage	12 VDC
Efficiency rating	Climate Savers Platinum Efficiency (80Plus Platinum certified)
Form factor	RSP2
Input connector	IEC320 C20

## 1050 W DC Power Supply

This section lists the specifications for each 1050 W DC power supply (Cisco part number UCSC-PSUV2-1050DC).

**Table 22: 1050 W DC Specifications**

Description	Specification
DC Input Voltage	Nominal range: -48 to -60 VDC (Range: -40 to -72 VDC)
Maximum DC input current	N32 A at -40 VDC
Maximum input wattage	1234 W
Maximum inrush current	35 A (sub-cycle duration)
Maximum hold-up time	5 ms at 100% load (1050 W main and 36 W standby)
Maximum output power per PSU	1050 W on 12 VDC main power 36 W on 12 VDC standby power
Power supply output voltage	12 VDC
Power supply standby voltage	12 VDC



Efficiency rating	≥ 92% at 50% load
Form factor	RSP2
Input connector	Fixed 3-wire block

## Power Cord Specifications

Each power supply in the server has a power cord. Standard power cords or jumper power cords are available for connection to the server. The shorter jumper power cords, for use in racks, are available as an optional alternative to the standard power cords.

For complete list of supported power cords, see *SELECT INPUT POWER CORD(s)* in [Cisco UCS C245 M6 SFF Rack Server](#)



---

**Note** Only the approved power cords or jumper power cords listed in the server spec sheet are supported.

---





# APPENDIX **B**

## GPU Installation

- [Server Firmware Requirements](#), on page 119
- [GPU Card Configuration Rules](#), on page 119
- [Requirement For All GPUs: Memory-Mapped I/O Greater Than 4 GB](#), on page 120
- [Installing a Single-Wide GPU Card](#), on page 121
- [Installing a Double-Wide GPU Card](#), on page 122
- [Using NVIDIA GRID License Server For P-Series and T-Series GPUs](#), on page 126

## Server Firmware Requirements

The following table lists the minimum server firmware versions for the supported GPU cards.

GPU Card	PID	Type	Number of Supported GPUs*	Cisco IMC/BIOS Minimum Version Required
NVIDIA Tesla A10	UCSC-GPU-A10 or HX-GPU-A10=	Single-wide	5	4.2(2f)
NVIDIA Tesla A16	UCSC-GPU-A16=or HX-GPU-A16=	Double-wide	3	4.2(2f)
NVIDIA Tesla A30	UCSC-GPU-A30=or HX-GPU-A30=	Double-wide	3	4.2(2f)
NVIDIA Tesla A40	UCSC-GPU-A40 or HX-GPU-A40=	Double-wide	3	4.2(2f)
NVIDIA Tesla A100	UCSC-GPU-A100=	Double-wide	3	4.2(2f)
NVIDIA Tesla A100-80	UCSC-GPU-A100-80=	Double-wide	3	4.2(2f)

## GPU Card Configuration Rules

Note the following rules when populating a server with GPU cards.



**Caution** When using NVIDIA Tesla GPU cards in this server, there are special temperature requirements. See [Installing a Double-Wide GPU Card](#), on page 122.

- Use the UCS power calculator at the following link to determine the power needed based on your server configuration: <http://ucspowercalc.cisco.com>
- Up to two double-wide GPU cards are supported in PCIe riser 1, slot 2 and in PCIe riser 2, slot 5.



**Note** Double-wide GPU cards are not supported in all PCIe riser options. Double-wide GPU cards are supported only in the following riser options:

- PCIe riser 1 with Riser 1A (UCSC-RIS1A-240M6)
- PCIe riser 2 with Riser 2A (UCSC-RIS2A-240M6)
- PCIe riser 3 with Riser 3A (UCSC-RIS3A-240M6) or Riser 3C (UCSC-RIS3C-240M6)



**Note** Only with slot 7.

- A double-wide GPU card installed in slot 2 also covers slot 4; a double wide GPU card installed in slot 5 also covers slot 6.
- Do not mix different brands or models of GPU cards in the server.
- You can install a GPU card and a Cisco UCS VIC in the same riser. When you install a GPU card in slot 2, NCSI support in riser 1 automatically moves to slot 1. When you install a GPU card in slot 5, NCSI support in riser 2 automatically moves to slot 4.
- Some GPUs have a limitation on whether they can support 1 TB or more memory in the server.

## Requirement For All GPUs: Memory-Mapped I/O Greater Than 4 GB

All supported GPU cards require enablement of the BIOS setting that allows greater than 4 GB of memory-mapped I/O (MMIO).

In standalone mode, BIOS setting is enabled by default:

**Advanced > PCI Configuration > Memory Mapped I/O Above 4 GB > Enabled**

**Step 1** If you need to change this setting, enter the BIOS Setup Utility by pressing **F2** when prompted during bootup.

**Step 2** Browse to **Advanced > PCI Configuration > Memory Mapped I/O Above 4 GB**.

---

## Installing a Single-Wide GPU Card

Use the following procedure to install or replace the following supported single-wide GPU cards:

---

**Step 1** Shut down and remove power from the server as described in [Shutting Down and Removing Power From the Server](#), on page 34.

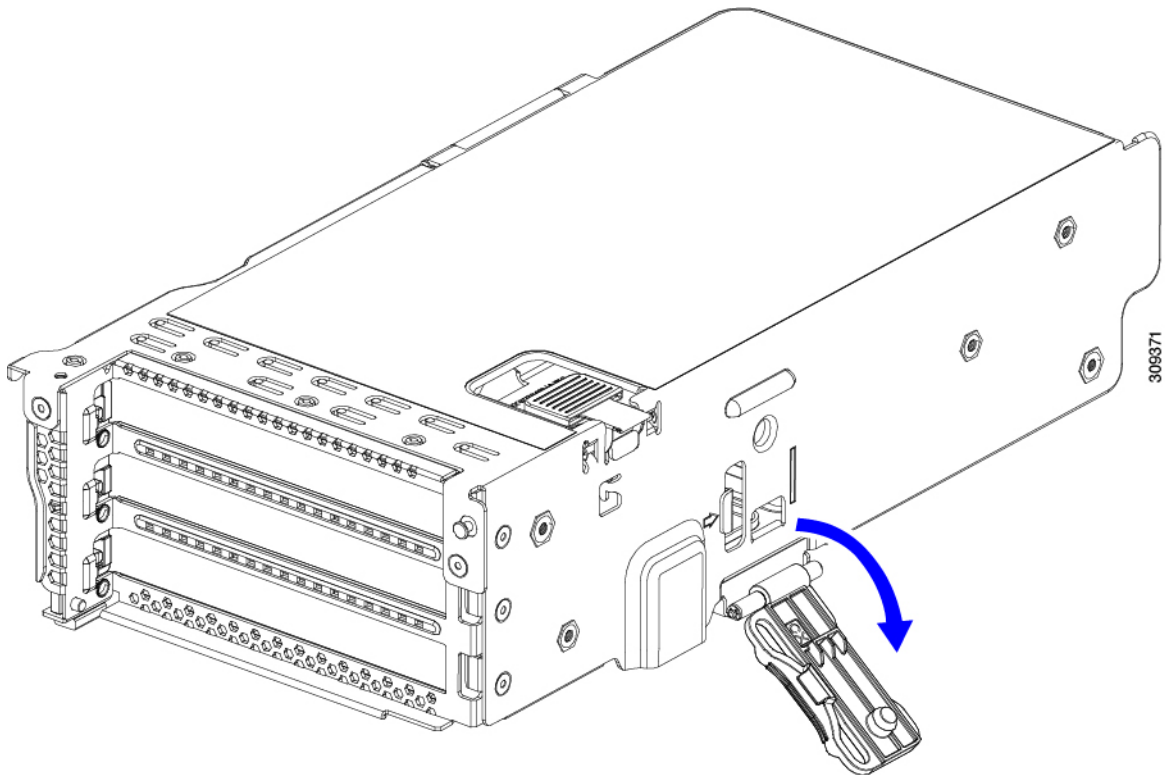
**Step 2** Slide the server out the front of the rack far enough so that you can remove the top cover. You might have to detach cables from the rear panel to provide clearance.

**Caution** If you cannot safely view and access the component, remove the server from the rack.

**Step 3** Remove the top cover from the server as described in [Removing the Server Top Cover](#), on page 35.

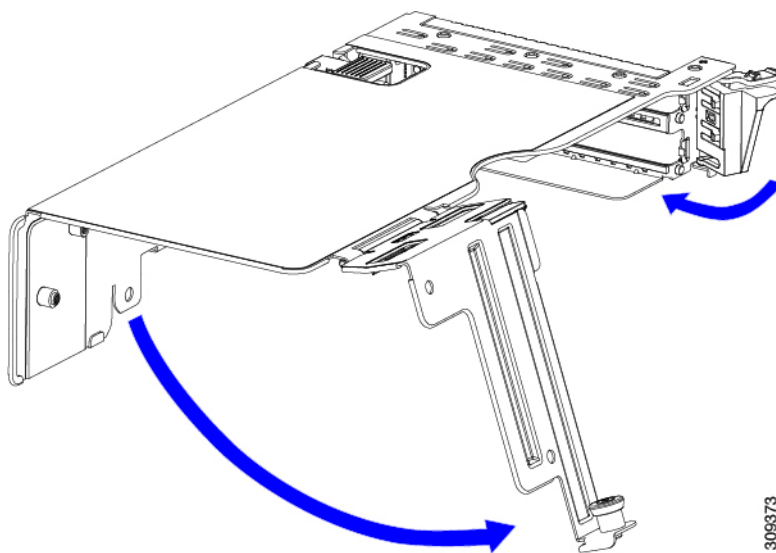
**Step 4** Remove the single-wide GPU card that you are replacing:

- a) Use two hands to flip up and grasp the blue riser handle and the blue finger grip area on the front edge of the riser, and then lift straight up.



- b) On the bottom of the riser, push the release latch that holds the securing plate, and then swing the hinged securing plate open.
- c) Open the hinged card-tab retainer that secures the rear-panel tab of the card.

Figure 49: PCIe Riser Card Securing Mechanisms



1	Release latch on hinged securing plate	3	Hinged card-tab retainer
2	Hinged securing plate	-	

- d) Pull evenly on both ends of the single-wide GPU card to remove it from the socket on the PCIe riser.  
If the riser has no card, remove the blanking panel from the rear opening of the riser.

**Step 5** Install a new single-wide GPU card:

- With the hinged card-tab retainer open, align the new single-wide GPU card with the empty socket on the PCIe riser.
- Push down evenly on both ends of the card until it is fully seated in the socket.
- Ensure that the card's rear panel tab sits flat against the riser rear-panel opening and then close the hinged card-tab retainer over the card's rear-panel tab.
- Swing the hinged securing plate closed on the bottom of the riser. Ensure that the clip on the plate clicks into the locked position.
- Position the PCIe riser over its socket on the motherboard and over the chassis alignment channels.
- Carefully push down on both ends of the PCIe riser to fully engage its connector with the sockets on the motherboard.

**Step 6** Replace the top cover to the server.

**Step 7** Replace the server in the rack, replace cables, and then fully power on the server by pressing the Power button.

**Step 8** Optional: Continue with [Installing Drivers to Support the GPU Cards](#), on page 133.

**Note** If you installed an NVIDIA Tesla M-series or P-Series GPU, you must install GRID licenses to use the GRID features. See [Using NVIDIA GRID License Server For P-Series and T-Series GPUs](#), on page 126.

## Installing a Double-Wide GPU Card

Use the following procedure to install or replace the following supported double-wide GPU card:



**Note** When using double-wide GPU cards in this server, there are special temperature requirements, as described in the table below.

**Table 23: UCS C245 M6 Operating Temperature Requirements For Double-Wide GPU Cards**

GPU Card Type	Maximum Server Operating Temperature (Air Inlet Temperature)
NVIDIA Tesla	30° C (86.0° F)



**Note For NVIDIA GPUs:** The NVIDIA GPU card might be shipped with two power cables: a straight cable and a Y-cable. The straight cable is used for connecting power to the GPU card in this server; do not use the Y-cable, which is used for connecting the GPU card in external devices only (such as the Magma chassis).

In the table below, the cable that is used with the GPU is listed. It is also indicated whether the cable is included in the GPU BOM or must be ordered separately.

- Separate = Cable must be ordered separately when the ordering tool prompts you.
- Included = Cable is included with the GPU; no additional action is needed.

**Table 24: Double-Wide GPU Required Power Cables**

GPU	GPU Power Cable	Cable Included When the GPU Card is Ordered With a System Order?	Cable Included When the GPU Card is Ordered as a Spare?
NVIDIA Tesla A10 24GB	UCS-P100CBL-240M5	Included	Separate
NVIDIA Tesla A100 40GB	UCS-P100CBL-240M5	Included	Separate

**Step 1** Shut down and remove power from the server as described in [Shutting Down and Removing Power From the Server, on page 34](#).

**Step 2** Slide the server out the front of the rack far enough so that you can remove the top cover. You might have to detach cables from the rear panel to provide clearance.

**Caution** If you cannot safely view and access the component, remove the server from the rack.

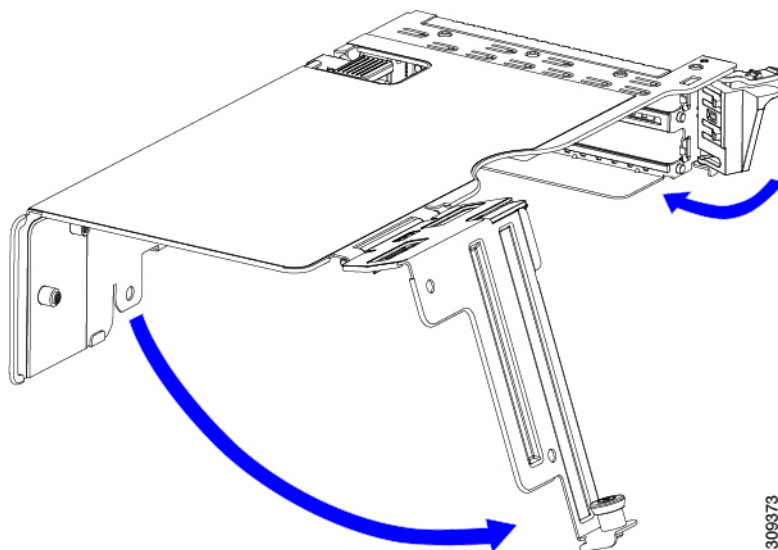
**Step 3** Remove the top cover from the server as described in [Removing the Server Top Cover, on page 35](#).

**Step 4** Remove an existing GPU card:

- Use two hands to grasp the metal bracket of the PCIe riser and lift straight up to disengage its connector from the socket on the motherboard. Set the riser on an antistatic surface.
- On the bottom of the riser, press down on the clip that holds the securing plate.
- Swing open the hinged securing plate to provide access.
- Open the hinged plastic retainer that secures the rear-panel tab of the card.

- e) Disconnect the GPU card's power cable from the power connector on the PCIe riser.
- f) Pull evenly on both ends of the GPU card to remove it from the socket on the PCIe riser.

**Figure 50: PCIe Riser Card Securing Mechanisms**



<b>1</b>	Release latch on hinged securing plate	<b>3</b>	Hinged card-tab retainer
<b>2</b>	Hinged securing plate	-	

**Step 5** Install a new GPU card:

**Note** Observe the configuration rules for this server, as described in [GPU Card Configuration Rules, on page 119](#).

- a) Align the GPU card with the socket on the riser, and then gently push the card's edge connector into the socket. Press evenly on both corners of the card to avoid damaging the connector.
- b) Connect the GPU power cable. The straight power cable connectors are color-coded. Connect the cable's black connector into the black connector on the GPU card and the cable's white connector into the white GPU POWER connector on the PCIe riser.

**Caution** Do not reverse the straight power cable. Connect the *black* connector on the cable to the *black* connector on the GPU card. Connect the *white* connector on the cable to the *white* connector on the PCIe riser.

- c) Close the card-tab retainer over the end of the card.
- d) Swing the hinged securing plate closed on the bottom of the riser. Ensure that the clip on the plate clicks into the locked position.
- e) Position the PCIe riser over its socket on the motherboard and over the chassis alignment channels.
- f) Carefully push down on both ends of the PCIe riser to fully engage its connector with the sockets on the motherboard.

At the same time, align the GPU front support bracket (on the front end of the GPU card) with the securing latch that is on the server's air baffle.

**Step 6** Insert the GPU front support bracket into the latch that is on the air baffle:

- a) Pinch the latch release tab and hinge the latch toward the front of the server.
- b) Hinge the latch back down so that its lip closes over the edge of the GPU front support bracket.



- c) Ensure that the latch release tab clicks and locks the latch in place.

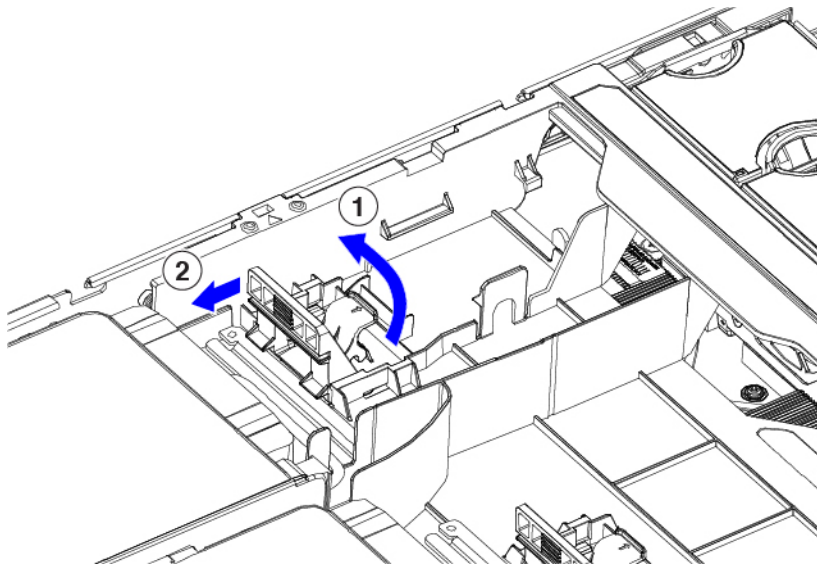
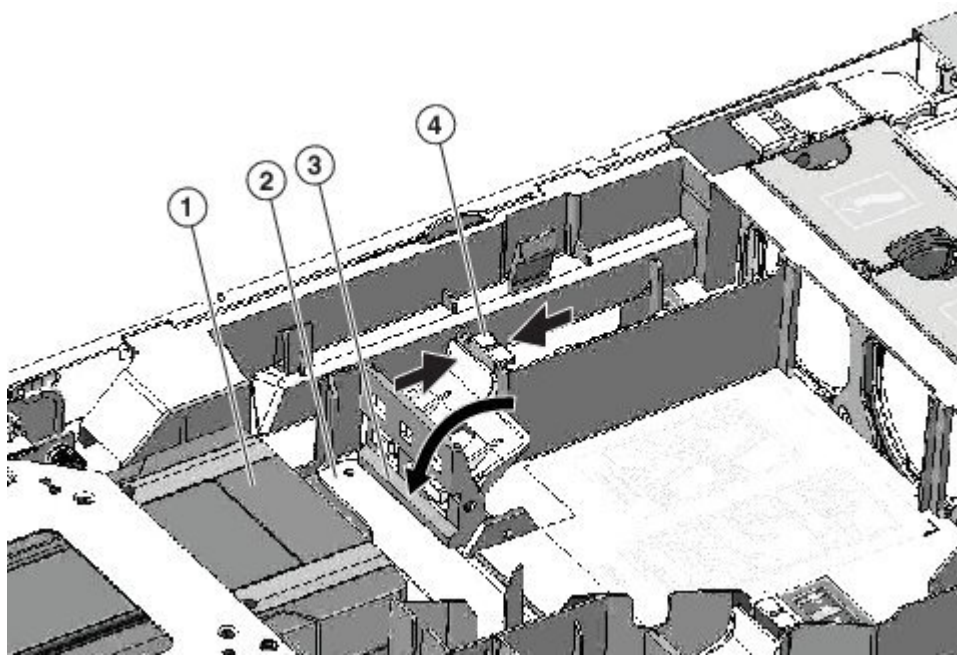


Figure 51: GPU Front Support Bracket Inserted to Securing latch on Air Baffle



1	Front end of GPU card	3	Lip on securing latch
2	GPU front support bracket	4	Securing latch release tab

**Step 7** Replace the top cover to the server.

**Step 8** Replace the server in the rack, replace cables, and then fully power on the server by pressing the Power button.

**Step 9** Optional: Continue with [Installing Drivers to Support the GPU Cards](#), on page 133.

**Note** If you installed an NVIDIA Tesla M-series GPU, you must install GRID licenses to use the GRID features. See [Using NVIDIA GRID License Server For P-Series and T-Series GPUs, on page 126](#).

---

## Using NVIDIA GRID License Server For P-Series and T-Series GPUs

This section applies to NVIDIA Tesla P-Series and T-Series GPUs.

Use the topics in this section in the following order when obtaining and using NVIDIA GRID licenses.

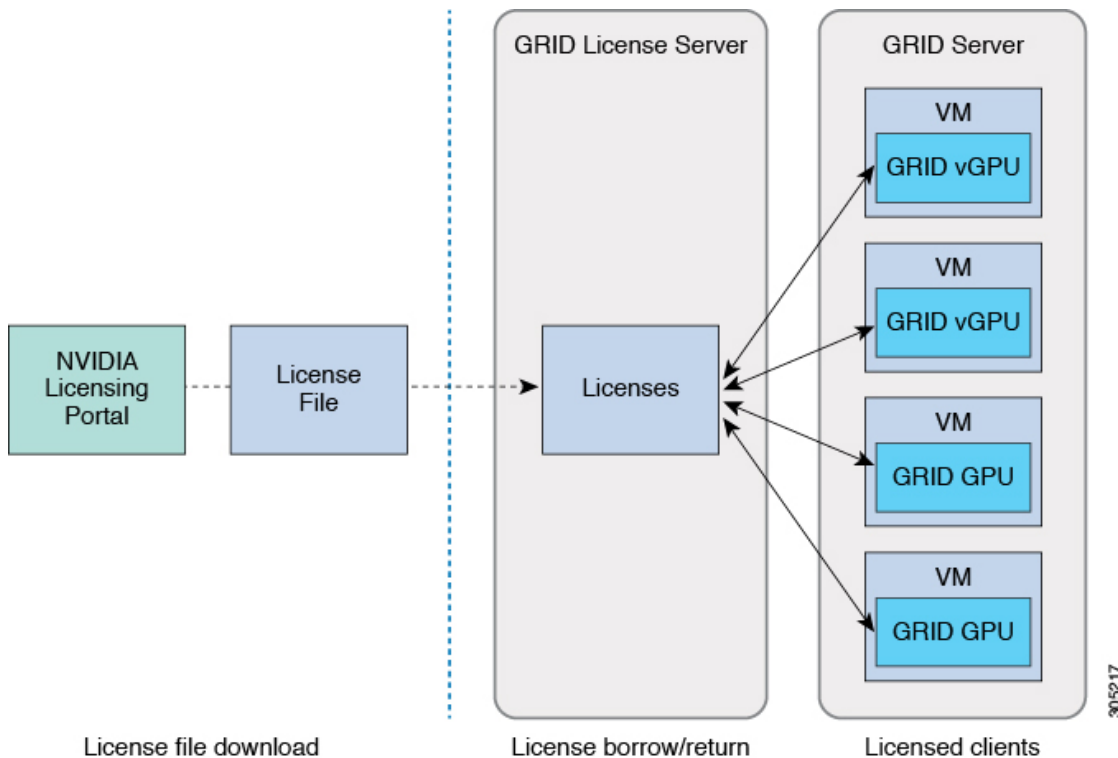
1. Familiarize yourself with the NVIDIA GRID License Server.  
[NVIDIA GRID License Server Overview, on page 126](#)
2. Register your product activation keys with NVIDIA.  
[Registering Your Product Activation Keys With NVIDIA, on page 127](#)
3. Download the GRID software suite.  
[Downloading the GRID Software Suite, on page 128](#)
4. Install the GRID License Server software to a host.  
[Installing NVIDIA GRID License Server Software, on page 128](#)
5. Generate licenses on the NVIDIA Licensing Portal and download them.  
[Installing Licenses From the Licensing Portal, on page 130](#)
6. Manage your GRID licenses.  
[Managing GRID Licenses , on page 131](#)

### NVIDIA GRID License Server Overview

The NVIDIA M-Series GPUs combine Tesla and GRID functionality when the licensed GRID features such as GRID vGPU and GRID Virtual Workstation are enabled. These features are enabled during OS boot by borrowing a software license that is served over the network from the NVIDIA GRID License Server virtual appliance. The license is returned to the license server when the OS shuts down.

You obtain the licenses that are served by the GRID License Server from NVIDIA's Licensing Portal as downloadable license files, which you install into the GRID License Server via its management interface.

Figure 52: NVIDIA GRID Licensing Architecture



There are three editions of GRID licenses, which enable three different classes of GRID features. The GRID software automatically selects the license edition based on the features that you are using.

GRID License Edition	GRID Feature
GRID Virtual GPU (vGPU)	Virtual GPUs for business desktop computing
GRID Virtual Workstation	Virtual GPUs for midrange workstation computing
GRID Virtual Workstation – Extended	Virtual GPUs for high-end workstation computing Workstation graphics on GPU pass-through

## Registering Your Product Activation Keys With NVIDIA

After your order is processed, NVIDIA sends you a Welcome email that contains your product activation keys (PAKs) and a list of the types and quantities of licenses that you purchased.

- 
- Step 1** Select the **Log In** link, or the **Register** link if you do not already have an account.  
The NVIDIA Software Licensing Center > License Key Registration dialog opens.
- Step 2** Complete the License Key Registration form and then click **Submit My Registration Information**.  
The NVIDIA Software Licensing Center > Product Information Software dialog opens.

- Step 3** If you have additional PAKs, click **Register Additional Keys**. For each additional key, complete the form on the License Key Registration dialog and then click **Submit My Registration Information**.
- Step 4** Agree to the terms and conditions and set a password when prompted.
- 

## Downloading the GRID Software Suite

---

- Step 1** Return to the NVIDIA Software Licensing Center > Product Information Software dialog.
- Step 2** Click the **Current Releases** tab.
- Step 3** Click the **NVIDIA GRID** link to access the Product Download dialog. This dialog includes download links for:
- NVIDIA License Manager software
  - The gpumodeswitch utility
  - The host driver software
- Step 4** Use the links to download the software.
- 

## Installing NVIDIA GRID License Server Software

For full installation instructions and troubleshooting, refer to the *NVIDIA GRID License Server User Guide*. Also refer to the *NVIDIA GRID License Server Release Notes* for the latest information about your release.

<http://www.nvidia.com>

### Platform Requirements for NVIDIA GRID License Server

- The hosting platform can be a physical or a virtual machine. NVIDIA recommends using a host that is dedicated only to running the License Server.
- The hosting platform must run a supported Windows OS.
- The hosting platform must have a constant IP address.
- The hosting platform must have at least one constant Ethernet MAC address.
- The hosting platform's date and time must be set accurately.

## Installing GRID License Server on Windows

The License Server requires a Java runtime environment and an Apache Tomcat installation. Apache Tomcat is installed when you use the NVIDIA installation wizard for Windows.

---

- Step 1** Download and install the latest Java 32-bit runtime environment from <https://www.oracle.com/downloads/index.html>.
- Note** Install the 32-bit Java Runtime Environment, regardless of whether your platform is Windows 32-bit or 64-bit.

- Step 2** Create a server interface:
- On the NVIDIA Software Licensing Center dialog, click **Grid Licensing > Create License Server**.
  - On the Create Server dialog, fill in your desired server details.
  - Save the .bin file that is generated onto your license server for installation.
- Step 3** Unzip the NVIDIA License Server installer Zip file that you downloaded previously and run setup.exe.
- Step 4** Accept the EULA for the NVIDIA License Server software and the Apache Tomcat software. Tomcat is installed automatically during the License Server installation.
- Step 5** Use the installer wizard to step through the installation.
- Note** On the Choose Firewall Options dialog, select the ports to be opened in the firewall. NVIDIA recommends that you use the default setting, which opens port 7070 but leaves port 8080 closed.
- Step 6** Verify the installation. Open a web browser on the License Server host and connect to the URL <http://localhost:8080/licserver>. If the installation was successful, you see the NVIDIA License Client Manager interface.
- 

## Installing GRID License Server on Linux

The License Server requires a Java runtime environment and an Apache Tomcat installation. You must install both separately before installing the License Server on Linux.

---

- Step 1** Verify that Java was installed with your Linux installation. Use the following command:
- ```
java -version
```
- If no Java version is displayed, use your Linux package manager to install with the following command:
- ```
sudo yum install java
```
- Step 2** Use your Linux package manager to install the tomcat and tomcat-webapps packages:
- Use the following command to install Tomcat:

```
sudo yum install tomcat
```
  - Enable the Tomcat service for automatic startup on boot:

```
sudo systemctl enable tomcat.service
```
  - Start the Tomcat service:

```
sudo systemctl start tomcat.service
```
  - Verify that the Tomcat service is operational. Open a web browser on the License Server host and connect to the URL <http://localhost:8080>. If the installation was successful, you see the Tomcat webapp.
- Step 3** Install the License Server:
- Unpack the License Server tar file using the following command:

```
tar xzf NVIDIA-linux-2015.09-0001.tgz
```
  - Run the unpacked setup binary as root:

```
sudo ./setup.bin
```
  - Accept the EULA and then continue with the installation wizard to finish the installation.

**Note** On the Choose Firewall Options dialog, select the ports to be opened in the firewall. NVIDIA recommends that you use the default setting, which opens port 7070 but leaves port 8080 closed.

**Step 4** Verify the installation. Open a web browser on the License Server host and connect to the URL <http://localhost:8080/licserver>. If the installation was successful, you see the NVIDIA License Client Manager interface.

---

## Installing GRID Licenses From the NVIDIA Licensing Portal to the License Server

### Accessing the GRID License Server Management Interface

Open a web browser on the License Server host and access the URL <http://localhost:8080/licserver>.

If you configured the License Server host's firewall to permit remote access to the License Server, the management interface is accessible from remote machines at the URL <http://hostname:8080/licserver>

## Reading Your License Server's MAC Address

Your License Server's Ethernet MAC address is used as an identifier when registering the License Server with NVIDIA's Licensing Portal.

---

**Step 1** Access the GRID License Server Management Interface in a browser.

**Step 2** In the left-side License Server panel, select **Configuration**.

The License Server Configuration panel opens. Next to **Server host ID**, a pull-down menu lists the possible Ethernet MAC addresses.

**Step 3** Select your License Server's MAC address from the **Server host ID** pull-down.

**Note** It is important to use the same Ethernet ID consistently to identify the server when generating licenses on NVIDIA's Licensing Portal. NVIDIA recommends that you select one entry for a primary, non-removable Ethernet interface on the platform.

---

## Installing Licenses From the Licensing Portal

**Step 1** Access the GRID License Server Management Interface in a browser.

**Step 2** In the left-side License Server panel, select **Configuration**.

The License Server Configuration panel opens.

**Step 3** Use the License Server Configuration menu to install the .bin file that you generated earlier.

- Click **Choose File**.
- Browse to the license .bin file that you want to install and click **Open**.
- Click **Upload**.

The license file is installed on your License Server. When installation is complete, you see the confirmation message, “Successfully applied license file to license server.”

---

## Viewing Available GRID Licenses

Use the following procedure to view which licenses are installed and available, along with their properties.

- 
- Step 1** Access the GRID License Server Management Interface in a browser.
  - Step 2** In the left-side License Server panel, select **Licensed Feature Usage**.
  - Step 3** Click on a feature in the **Feature** column to see detailed information about the current usage of that feature.
- 

## Viewing Current License Usage

Use the following procedure to view information about which licenses are currently in-use and borrowed from the server.

- 
- Step 1** Access the GRID License Server Management Interface in a browser.
  - Step 2** In the left-side License Server panel, select **Licensed Clients**.
  - Step 3** To view detailed information about a single licensed client, click on its **Client ID** in the list.
- 

## Managing GRID Licenses

Features that require GRID licensing run at reduced capability until a GRID license is acquired.

### Acquiring a GRID License on Windows

---

- Step 1** Open the NVIDIA Control Panel using one of the following methods:
  - Right-click on the Windows desktop and select **NVIDIA Control Panel** from the menu.
  - Open Windows Control Panel and double-click the **NVIDIA Control Panel** icon.
- Step 2** In the NVIDIA Control Panel left-pane under Licensing, select **Manage License**.

The Manage License task pane opens and shows the current license edition being used. The GRID software automatically selects the license edition based on the features that you are using. The default is Tesla (unlicensed).
- Step 3** If you want to acquire a license for GRID Virtual Workstation, under License Edition, select **GRID Virtual Workstation**.
- Step 4** In the **License Server** field, enter the address of your local GRID License Server. The address can be a domain name or an IP address.
- Step 5** In the **Port Number** field, enter your port number of leave it set to the default used by the server, which is 7070.
- Step 6** Select **Apply**.

The system requests the appropriate license edition from your configured License Server. After a license is successfully acquired, the features of that license edition are enabled.

**Note** After you configure licensing settings in the NVIDIA Control Panel, the settings persist across reboots.

---

## Acquiring a GRID License on Linux

---

**Step 1** Edit the configuration file `/etc/nvidia/gridd.conf`:

```
sudo vi /etc/nvidia/gridd.conf
```

**Step 2** Edit the Server URL line with the address of your local GRID License Server.

The address can be a domain name or an IP address. See the example file below.

**Step 3** Append the port number (default 7070) to the end of the address with a colon. See the example file below.

**Step 4** Edit the FeatureType line with the integer for the license type. See the example file below.

- GRID vGPU = 1
- GRID Virtual Workstation = 2

**Step 5** Restart the `nvidia-gridd` service.

```
sudo service nvidia-gridd restart
```

The service automatically acquires the license edition that you specified in the FeatureType line. You can confirm this in `/var/log/messages`.

**Note** After you configure licensing settings in the NVIDIA Control Panel, the settings persist across reboots.

Sample configuration file:

```
# /etc/nvidia/gridd.conf - Configuration file for NVIDIA Grid Daemon
# Description: Set License Server URL
# Data type: string
# Format: "<address>:<port>"
ServerUrl=10.31.20.45:7070

# Description: Set Feature to be enabled
# Data type: integer
# Possible values:
# 1 => for GRID vGPU
# 2 => for GRID Virtual Workstation
FeatureType=2
```

---

## Using gpumodeswitch

The command line utility `gpumodeswitch` can be run in the following environments:

- Windows 64-bit command prompt (requires administrator permissions)
- Linux 32/64-bit shell (including Citrix XenServer dom0) (requires root permissions)





**Note** Consult NVIDIA product release notes for the latest information on compatibility with compute and graphic modes.

The `gpmodeswitch` utility supports the following commands:

- `--listgpumodes`

Writes information to a log file named `listgpumodes.txt` in the current working directory.

- `--gpumode graphics`

Switches to graphics mode. Switches mode of all supported GPUs in the server unless you specify otherwise when prompted.

- `--gpumode compute`

Switches to compute mode. Switches mode of all supported GPUs in the server unless you specify otherwise when prompted.



**Note** After you switch GPU mode, reboot the server to ensure that the modified resources of the GPU are correctly accounted for by any OS or hypervisor running on the server.

## Installing Drivers to Support the GPU Cards

After you install the hardware, you must update to the correct level of server BIOS and then install GPU drivers and other software in this order:

1. Update the server BIOS.
2. Update the GPU drivers.

### 1. Updating the Server BIOS

Install the latest BIOS by using the Host Upgrade Utility.



**Note** You must do this procedure before you update the NVIDIA drivers.

- Step 1** Navigate to the following URL: <http://www.cisco.com/cisco/software/navigator.html>.
- Step 2** Click **Servers–Unified Computing** in the middle column.
- Step 3** Click **Cisco UCS C-Series Rack-Mount Standalone Server Software** in the right-hand column.
- Step 4** Click the name of your model of server in the right-hand column.
- Step 5** Click **Unified Computing System (UCS) Server Firmware**.
- Step 6** Click the release number.
- Step 7** Click **Download Now** to download the `ucs-server platform-huu-version_number.iso` file.
- Step 8** Verify the information on the next page, and then click **Proceed With Download**.

**2. Updating the GPU Card Drivers**

- Step 9** Continue through the subsequent screens to accept the license agreement and browse to a location where you want to save the file.
- Step 10** Use the Host Upgrade Utility to update the server BIOS.  
The user guides for the Host Upgrade Utility are at [Utility User Guides](#).
- 

**2. Updating the GPU Card Drivers**

After you update the server BIOS, you can install GPU drivers to your hypervisor virtual machine.

---

- Step 1** Install your hypervisor software on a computer. Refer to your hypervisor documentation for the installation instructions.
- Step 2** Create a virtual machine in your hypervisor. Refer to your hypervisor documentation for instructions.
- Step 3** Install the GPU drivers to the virtual machine. Download the drivers from either:
- NVIDIA Enterprise Portal for GRID hypervisor downloads (requires NVIDIA login):  
<https://nvidia.flexnetoperations.com/>
  - NVIDIA public driver area: <http://www.nvidia.com/Download/index.aspx>
  - AMD: <http://support.amd.com/en-us/download>
- Step 4** Restart the server.
- Step 5** Check that the virtual machine is able to recognize the GPU card. In Windows, use the Device Manager and look under Display Adapters.
-



# APPENDIX C

## Storage Controller Considerations

- [Supported Storage Controllers and Cables, on page 135](#)
- [Storage Controller Card Firmware Compatibility, on page 136](#)
- [RAID Backup \(Supercap\), on page 136](#)
- [Write-Cache Policy for Cisco 12G SAS Modular RAID Controllers, on page 136](#)
- [Mixing Drive Types in RAID Groups, on page 137](#)
- [Storage Controller Cable Connectors and Backplanes, on page 137](#)

## Supported Storage Controllers and Cables

This server supports a single, PCIe-style, SAS RAID or HBA controller that plugs into a dedicated internal socket.



**Note** NVMe PCIe SSDs cannot be controlled by RAID controller.

This server supports the RAID and HBA controller options and cable requirements shown in the following table.

Controller	Server Version/Maximum Drives Controlled	RAID Levels	Optional Supercap Backup?	Required Cables
Cisco 12G Modular RAID Controller UCSC-RAID-M6 Includes 4GB flash-back write cache (FBWC); controls up to 24 drives.	<ul style="list-style-type: none"> <li>• SFF 24-drives Supports up to 24 internal SAS/SATA drives</li> <li>• Upto 4 front NVMe drives (not managed by the storage controller)</li> <li>• Upto 4 Rear NVMe drives (2 each in Riser 1B and 3B)</li> </ul>	0, 1, 5, 6, 10, 50, 60, SRAID0  JBOD mode is also supported.	Yes	PCIe style controller. Plugs directly in to dedicated slot.

<p>Two Cisco 12G Modular SAS HBA UCSC-SAS-M6</p> <p>Each controller controls up to 12 drives.</p>	<ul style="list-style-type: none"> <li>• SFF 24-drives: Supports up to 16 SAS/SATA internal drives</li> <li>• Upto 4 front NVMe drives (not managed by the storage controller)</li> <li>• Upto 4 Rear NVMe drives (2 each in Riser 1B and 3B)</li> </ul>	<p>JBOD or pass-through mode (not RAID)</p>	<p>Yes</p>	<p>Plugs directly in to dedicated slot.</p>
---	--	---	------------	---

## Storage Controller Card Firmware Compatibility

Firmware on the storage controller (RAID or HBA) must be verified for compatibility with the current Cisco IMC and BIOS versions that are installed on the server. If not compatible, upgrade or downgrade the storage controller firmware using the Host Upgrade Utility (HUU) for your firmware release to bring it to a compatible level.



**Note** For servers running in standalone mode only: After you replace controller hardware (UCSC-RAID-M6, UCSC-RAID-M6HD, UCSC-SAS-M6, or UCSC-SAS-M6HD), you must run the Cisco UCS Host Upgrade Utility (HUU) to update the controller firmware, even if the firmware Current Version is the same as the Update Version. This is necessary to program the controller's suboem-id to the correct value for the server SKU. If you do not do this, drive enumeration might not display correctly in the software. This issue does not affect servers controlled in UCSM mode.

See the HUU guide for your Cisco IMC release for instructions on downloading and using the utility to bring server components to compatible levels: [HUU Guides](#).

## RAID Backup (Supercap)

This server supports installation of one Supercap unit. The unit mounts to a bracket in-line with the fan modules.

The optional SCPM provides approximately three years of backup for the disk write-back cache DRAM in the case of a sudden power loss by offloading the cache to the NAND flash.

For Supercap unit replacement instructions, see [Replacing the Supercap \(RAID Backup\)](#), on page 95.

## Write-Cache Policy for Cisco 12G SAS Modular RAID Controllers

For this server and other Cisco Generation M6 servers, the default write-cache policy for the Cisco Modular RAID controllers is flash-back write cache (FBWC). This utilizes the optimal performance characteristics of the controller.

You can change the write policy using the following methods:

- For standalone servers, use the Cisco IMC interface to set Virtual Drive Properties > Write Policy. See the “Managing Storage Adapters” section in your Cisco IMC Configuration Guide.

[Cisco IMC GUI and CLI Configuration Guides](#)

- Use the LSI Option ROM Configuration Utility.

## Mixing Drive Types in RAID Groups

- When you mix HDDs and SSDs ensure that:
  - all HDDs have their own RAID volume
  - all SSDs have their own RAID volume
- When using a Cisco M6 12G SAS RAID controller or Cisco 12G SAS HBA, you can mix SAS HDDs and SAS/SATA SSDs.
- SED drives can be mixed with the non-SED drives

## Storage Controller Cable Connectors and Backplanes

This section describes cabling for the storage controllers and backplanes. The SAS/SATA cables are factory-installed and are used for all supported internal controllers.

This section also contains diagrams that show the cable-to-drive mapping.

### **Cisco 12G Modular SAS RAID Controller or HBA For Up To 24 Drives (UCSC-RAID-M6HD or UCSC-SAS-M6HD)**

These controller are supported SFF 24-Drives server version.

This HW RAID or HBA option can control up to 24 front-loading SAS/SATA drives in this server version, plus 2 rear-loading SAS/SATA drives.



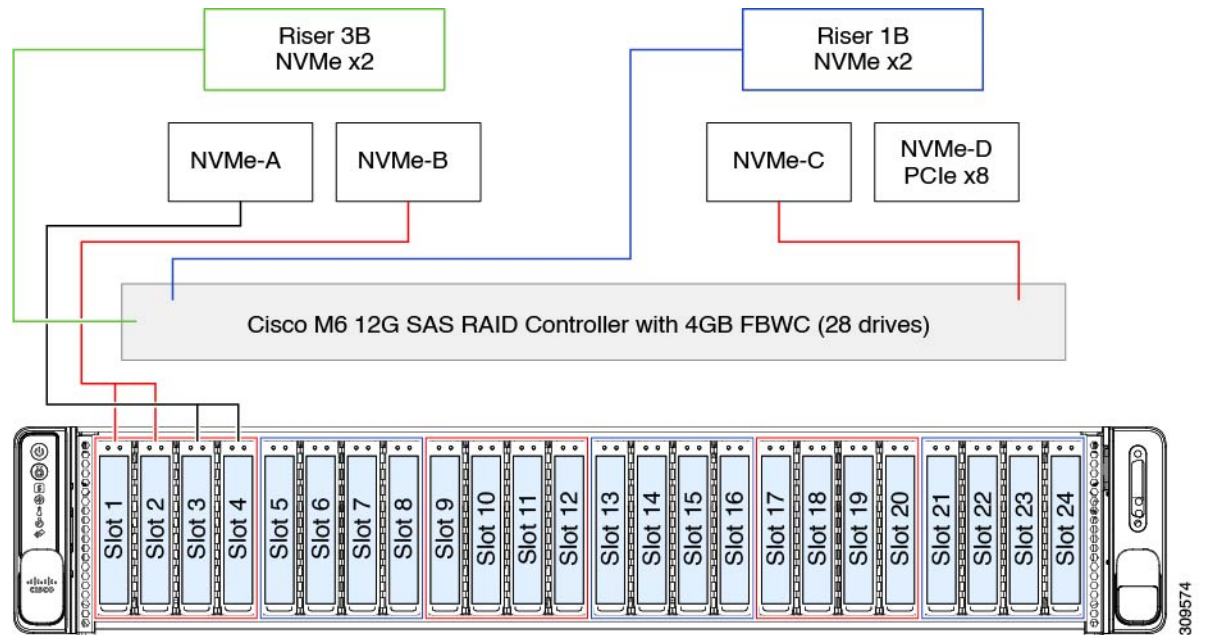
---

**Note** Front NVMe drives are not managed by the RAID controllers.

---

1. Server supports one Cisco M6 12G SAS RAID Controller that connects to the mother board.
  - Front-loading drive bays 1—24 support 2.5-inch SAS/SATA drives
  - Optionally, front-loading drive bays 1 to 4 support 2.5-inch NVMe SSDs (with optional front NVMe cables). These are not managed by the controller.
    - Drives 1 and 2 connect to NVMe connector A. Drives 3 and 4 connect to NVMe connector B.
  - Riser 1B and 3B support up to 2 NVMe SSDs each. These are connected to the controller.

Figure 53: Cisco UCS C245 M6 Block Diagram with Cisco M6 12G SAS RAID Controller



2. Server supports two Cisco M6 12G SAS HBA Controller that connects to the mother board.
  - Front-loading drive bays 1—24 support 2.5-inch SAS/SATA drives
  - Optionally, front-loading drive bays 1 to 4 support 2.5-inch NVMe SSDs (with optional front NVMe cables). These are not managed by the controller.

Drives 1 and 2 connect to NVMe connector A. Drives 3 and 4 connect to NVMe connector B.

  - Riser 1B and 3B support up to 2 NVMe SSDs each. Drives in riser 3B are connected to the slimline 4i connector on the controller on the same side as the riser. Similarly, riser 1B drives are connected to the slimline 4i connector on the controller on the same side.

Figure 54: Cisco UCS C245 M6 Block Diagram with Two Cisco M6 12G SAS HBA Controller

