



Overview

- [Features, on page 1](#)
- [Deployment Options, on page 5](#)
- [Package Contents, on page 5](#)
- [QR Code Sticker, on page 8](#)
- [Serial Number Location, on page 9](#)
- [Front Panel, on page 10](#)
- [Front Panel LEDs, on page 12](#)
- [Rear Panel, on page 18](#)
- [Network Modules, on page 20](#)
- [Hardware Bypass Network Modules, on page 23](#)
- [Power Supply Modules, on page 28](#)
- [Fan Modules, on page 31](#)
- [SSDs, on page 31](#)
- [Supported SFP/SFP+ Transceivers, on page 32](#)
- [Hardware Specifications, on page 34](#)
- [Product ID Numbers, on page 35](#)
- [Power Cord Specifications, on page 38](#)

Features

The Cisco Firepower 2100 series security appliance is a standalone modular security services platform. The series includes the Firepower 2110, 2120, 2130, and 2140. See [Product ID Numbers, on page 35](#) for a list of the product IDs (PIDs) associated with the 2100 series.

The Firepower 2100 series supports Cisco Firepower Threat Defense and Cisco ASA software. See the [Cisco Firepower Compatibility Guide](#) and the [Cisco ASA Compatibility](#) guide, which provide Cisco software and hardware compatibility, including operating system and hosting environment requirements, for each supported version.

The following figures show the Firepower 2100 series.

Figure 1: Firepower 2110 and 2120



Figure 2: Firepower 2130 and 2140



The following table lists the features for the Firepower 2100 series.

Table 1: Firepower 2100 Series Features

Feature	2110	2120	2130	2140
Form factor	1 RU Fits a standard 19-inch (48.3-cm) square-hole rack			
Rack mount	Two 2-post mount brackets (Optional) 4-post Electronic Industries Association (EIA)-310-D rack		4-post EIA-310-D rack (Optional) Two 2-post mount brackets	
Airflow	Front to rear Cold aisle to hot aisle			
Intel x86 processor	Single 4-core at 1.8 G	Single 6-core at 1.9 G	Single 8-core at 2.0 G	Single 16-core at 1.3 G
Intel x86 memory	16 GB DDR4 DRAM		32 GB DDR4 DRAM	64 GB DDR4 DRAM
Cavium Network Processor Unit (NPU)	Single 6-core at 1.2 G	Single 8-core at 1.2 G	Single 12-core at 1.2 G	Single 16-core at 1.8 G
Cavium NPU RAM	8 G		16G	
Flash	8 G (nominal)			

Feature	2110	2120	2130	2140
Maximum number of interfaces	16		24	
Management port	1 Gigabit Ethernet (10 M/100 M/1 G Base-T)			
Console port	RJ-45 serial port			
USB port	USB 2.0 Type A (500 mA)			
Network ports	12 fixed RJ-45 1 G/100 M/10 M ports (named Ethernet 1/1 through 1/12)			
Small form-factor pluggable (SFP) ports	Four fixed 1-G SFP ports		Four fixed 1-G/10-G SFP+ ports	
Pullout asset card	Displays serial number			
Grounding lug	On rear panel			
Locator beacon	On front panel			
Power switch	On rear panel			
Network module slots	No		One <i>Not</i> hot-swappable	
Network modules	—		<ul style="list-style-type: none"> • 8-port 1-Gigabit Ethernet SFP • 8-port 10-Gigabit Ethernet SFP+ • 8-port 1-Gigabit Ethernet copper with hardware bypass • 6-port 1-Gigabit Ethernet SX fiber SFP (built-in) with hardware bypass • 6-port 10-Gigabit Ethernet SR fiber SFP+ (built-in) with hardware bypass • 6-port 10-Gigabit Ethernet LR fiber SFP+ (built-in) with hardware bypass 	
AC power supply	One fixed AC power supply module		Two power supply slots Ships with one 400-W AC power supply module Hot-swappable	Two power supply slots Ships with two 400-W AC power supply modules Hot-swappable
DC power supply	No		Yes (optional)	
Redundant power	No		Yes	

Feature	2110	2120	2130	2140
Fan	Two fixed fans Internal component only; not field-replaceable		One hot-swappable fan tray with four fans	
Storage	Two SSD slots (100 GB) Ships with one 100-GB SSD installed in slot 1 Note We may ship larger capacity SSDs depending on component supply availability. The larger capacity SSDs are formatted to 100-GB for the Firepower 2110 and 2120. Slot 2 is reserved for the Malware Storage Pack (MSP).		Two SSD slots (200 GB) Ships with one 200-GB SSD installed in slot 1 Note We may ship larger capacity SSDs depending on component supply availability. The larger capacity SSDs are formatted to 200-GB for the Firepower 2130 and 2140. Slot 2 is reserved for the MSP.	
MSP	Installed in SSD slot 2			
Security standards certifications	<ul style="list-style-type: none"> • Common Criteria Certification for the Network Device Collaborative Protection Profile (NDcPPv2.2E), VPN Gateway Module (VPNGW_MOD_v1.1), and Firewall Module (FW_MOD_v1.4e) for ASA 9.16.x. • Common Criteria Certification for the Network Device Collaborative Protection Profile (NDcPPv2.2E), IPS Extended Package (IPSEP v2.11), Firewall Collaborative Protection Profile Module (MOD_FW_v1.4e), and Virtual Private Network Gateway Protection Profile Module (MOD_VPNGW_v1.1) on ASA 9.12.x, FTD 6.4.x and FX-OS 2.6.x • Federal Information Processing Standards (FIPS) 410-2 (FTD 6.4.x, FX-OS 2.6.x, and ASA 9.12.x) • Department of Defense Information Network Approved Product List (DoDIN APL) • US Government Compliance for IPv6 (USGv6) (FTD 6.4.x and ASA 9.12.x) • USGv6 Certification Approval under the R1 Profile for the Product Classification NPP (FTD 7.0.x) <p>Note See Install the FIPS Opacity Shield in a Two-Post Rack and Install the FIPS Opacity Shield in a Four-Post Rack for the procedures for installing the FIPS shield and for configuring the 2100 for FIPS mode.</p>			
Network Equipment Building Systems (NEBS) certification	—	—	Certified	—

Deployment Options

Here are some examples of how you can deploy the Firepower 2100:

- As a firewall:
 - At the enterprise Internet edge deployed in a high availability configuration
 - At branch offices in either a high availability pair or standalone
- As a device that provides additional application control, URL filtering, or IPS/threat-centric capabilities:
 - Behind an enterprise internet edge firewall in an inline in a transparent bump-in-the-wire configuration or as a standalone (requires hardware fail open network module support)
 - Deployed passively off a SPAN port on a switch or a tap on a network, or standalone
- As a VPN device:
 - For remote access VPN
 - For site-to-site VPN

Package Contents

The following figure shows the package contents for the Firepower 2110 and 2120. The contents are subject to change and your exact contents will contain additional or fewer items depending on whether you order the optional parts. See [Product ID Numbers, on page 35](#) for a list of the PIDs associated with the Firepower 2110 and 2120 package contents.



Note There are three sets of four screws that you can use to secure the chassis to your rack. Chose the screws that fit your rack.

Figure 3: Firepower 2110 and 2120 Package Contents

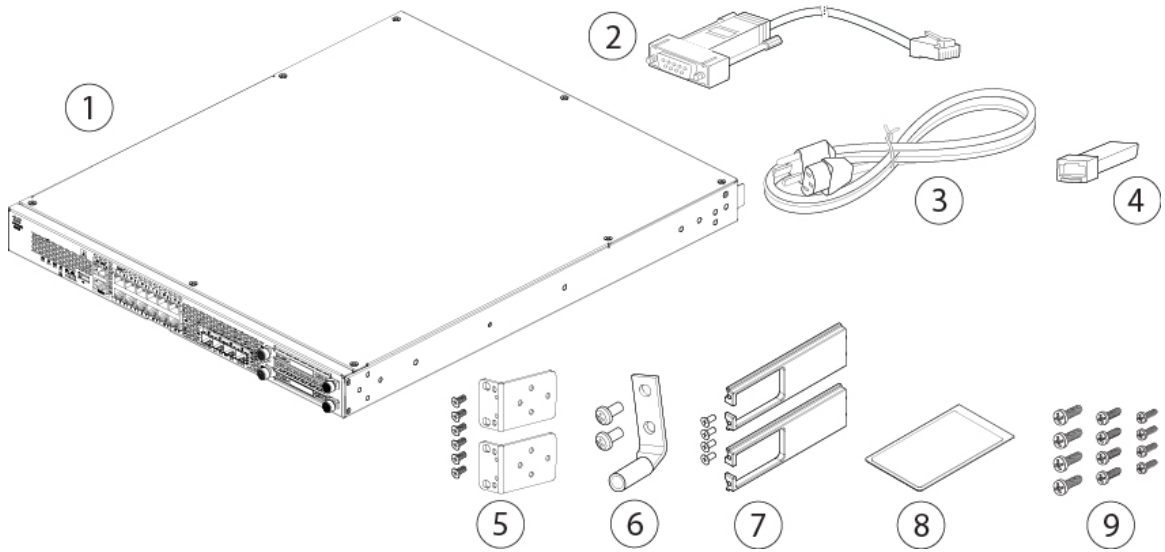

<p>1 Firepower 2110 or 2120 chassis</p>	<p>2 Console cable RJ-45 to DB-9 (part number 72-3383-01)</p>
<p>3 One power cord (country-specific) See Power Cord Specifications, on page 38 for the list of supported power cords.</p>	<p>4 SFP transceiver (Optional; in package if ordered)</p>
<p>5 Two rack-mount brackets (part number 700-106374-01) and six Phillips 8-32 x 0.281-inch screws (part number 48-101518-01)</p>	<p>6 One ground lug kit (part number 69-100359-01)</p> <ul style="list-style-type: none"> • One #6 AWG, 90 degree, #10 post ground lug (part number 32-0608-01) • Two 10-32 x 0.38-inch Phillips screws
<p>7 Cable management bracket kit (part number 69-100376-01)</p> <ul style="list-style-type: none"> • Two cable management brackets (part number 700-106377-01) • Four 8-32 x 0.375-inch Phillips screws (part number 48-2696-01) <p>(Optional; in package if ordered)</p>	<p>8 <i>Cisco Secure Firepower 2100</i></p> <p>This document has a URL and QR code that point to the Digital Documentation Portal. The portal contains links to the Product Information page, the Hardware Installation Guide, the Regulatory and Safety Information Guide, the Getting Started Guide, and the Easy Deployment Guide.</p>

9	<p>Rack-mount screws:</p> <ul style="list-style-type: none"> • Four 12-24 x 0.75-inch Phillips screws (part number 648-0440-01) for securing the chassis to your rack • Four 10-32 x 0.75-inch Phillips screws (part number 48-0441-01) for securing the chassis to your rack • Four M6 x 1 x 19-mm Phillips screws (part number 48-101022-01) for securing the chassis to your rack 	
----------	---	--

The following figure shows the package contents for the Firepower 2130 and 2140. The contents are subject to change and your exact contents will contain additional or fewer items depending on whether you order the optional parts. See [Product ID Numbers, on page 35](#) for a list of the product IDs (PIDs) associated with the Firepower 2130 and 2140 package contents.

Figure 4: Firepower 2130 and 2140 Package Contents

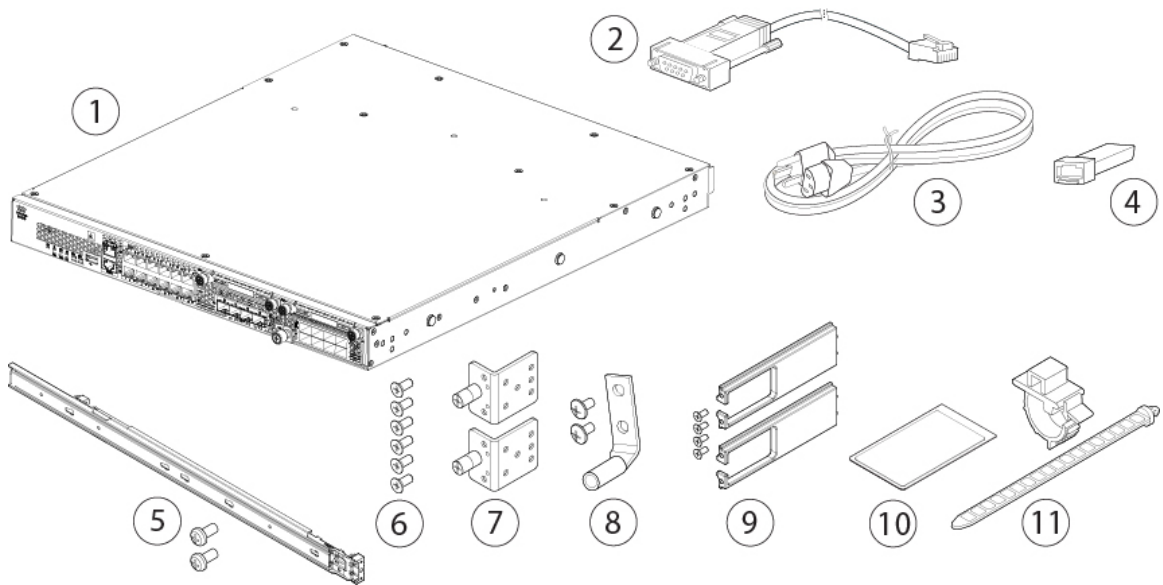

1	<p>Firepower 2130 or 2140 chassis</p>	2	<p>Console cable RJ-45 to DB-9 (part number 72-3383-01)</p>
3	<p>One or two power cords (country-specific) See Power Cord Specifications, on page 38 for a list of supported power cords.</p>	4	<p>SFP transceiver (Optional; in package if ordered)</p>
5	<p>Slide rail kit (part number 800-103711-01)</p> <ul style="list-style-type: none"> • Left and right slide rails • Two M3 x 0.5 x 6-mm Phillips screws (part number 48-101144-01) 	6	<p>Six 8-32 x 0.25-inch slide rail locking bracket Phillips screws (part number 48-101429-01)</p>

7	Two slide rail locking brackets (part number 700-105350-01)	8	One ground lug kit (part number 69-100359-01) <ul style="list-style-type: none"> • One #6 AWG, 90 degree, #10 post ground lug (part number 32-0608-01) • Two 10-32 x 0.38-inch Phillips screws
9	Cable management bracket kit (part number 69-100376-01) <ul style="list-style-type: none"> • Two cable management brackets (part number 700-106377-01) • Four 8-32 x 0.375-inch Phillips screws (part number 48-2696-01) (Optional; in package if ordered)	10	<i>Cisco Secure Firepower 2100</i> This document has a URL and QR code that point to the Digital Documentation Portal. The portal contains links to the Product Information page, the Hardware Installation Guide, the Regulatory and Safety Information Guide, the Getting Started Guide, and the Easy Deployment Guide.
11	Two power supply module tie wraps and clamps (part number 52-100162-01)	—	—

QR Code Sticker

The QR code sticker on the front panel of the chassis points to the [Easy Deployment Guide for Cisco Secure Firewall 1000, 2100, and 3100 Series](#) that explains low touch provisioning (LTP). LTP allows anyone to connect a new Firepower 2100 to a network so that the IT department can onboard the device to CDO and configure it remotely. CDO supports Firepower Threat Defense (FTD) version 6.7 and later.

The following figure shows the QR code sticker.

Figure 5: QR Code Sticker



The following figure shows the placement of the QR code sticker on the front panel of the Firepower 2100 chassis.

Figure 6: QR Code Sticker on the Firepower 2100 Front Panel

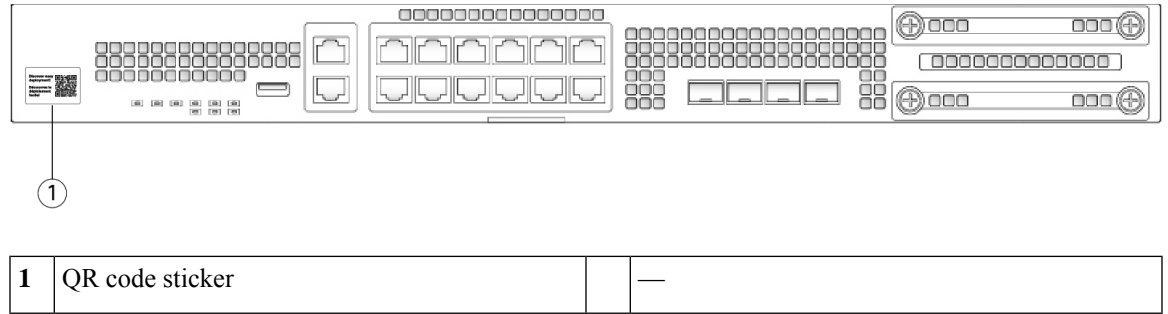

Serial Number Location

The serial number for the Firepower 2100 series chassis is located on the pullout asset card on the front panel.

Figure 7: Serial Number on the Chassis

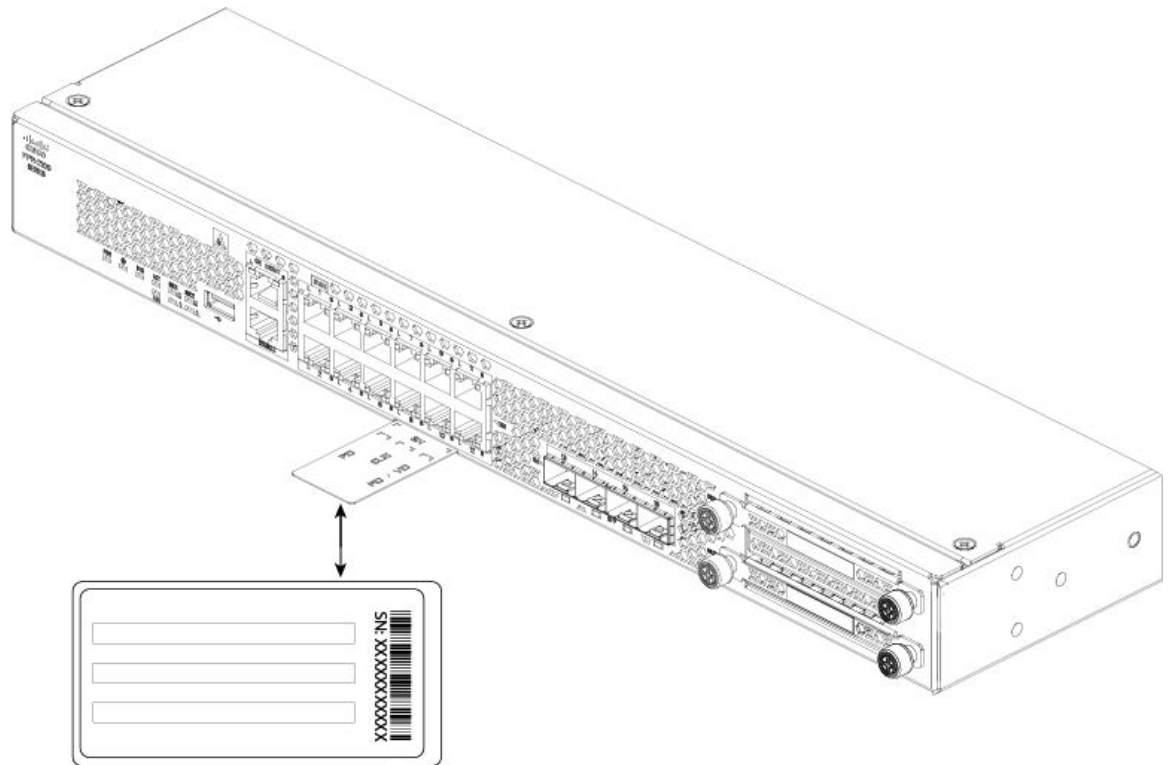

You can also view additional model information on the compliance label located on the bottom of the chassis.

Figure 8: Compliance Label on the Chassis

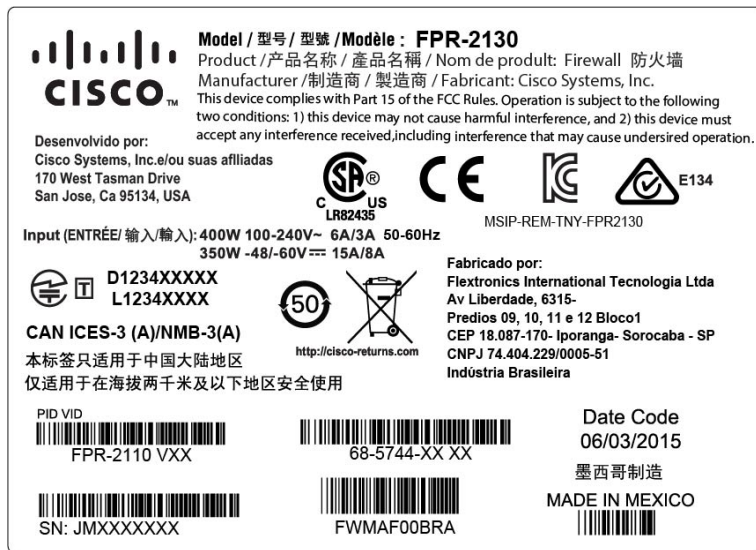

Front Panel

The following figure shows the front panel of the Firepower 2110 and 2120. See [Front Panel LEDs, on page 12](#) for a description of the LEDs.

Figure 9: Firepower 2110 and 2120 Front Panel

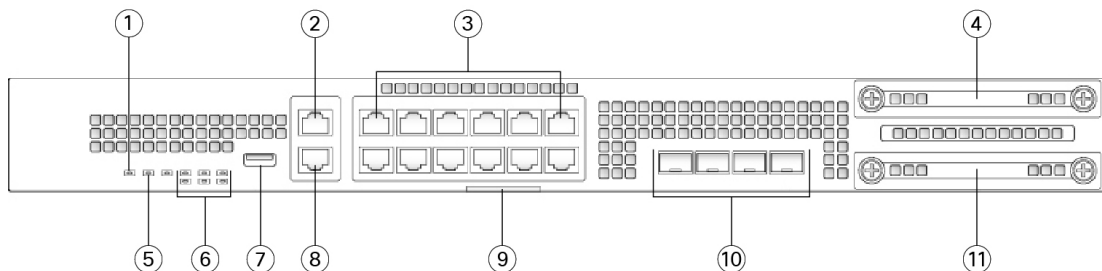

<p>1 Power LED</p>	<p>2 Gigabit Ethernet management port:</p> <ul style="list-style-type: none"> • Firepower Threat Defense—Management 0 (also referred to as Management 1/1 and Diagnostic 1/1) • ASA—Management 1/1
<p>3 12 RJ-45 1 G/100 M/10 M auto duplex/auto MDI-X Base-T ports</p> <p>Ethernet 1/1 through 1/12 labeled top to bottom, left to right</p>	<p>4 SSD 1 (slot 1)</p>

5	Locator LED	6	System LEDs
7	Type A USB 2.0 port	8	RJ-45 console port
9	Pullout asset card with chassis serial number	10	Four fixed SFP (1 Gb) ports Fiber ports 1/13 through 1/16 labeled left to right
11	SSD (slot 2)		—

The following figure shows the front panel of the Firepower 2130 and 2140. See [Front Panel LEDs](#), on page 12 for a description of the LEDs.

Figure 10: Firepower 2130 and 2140 Front Panel

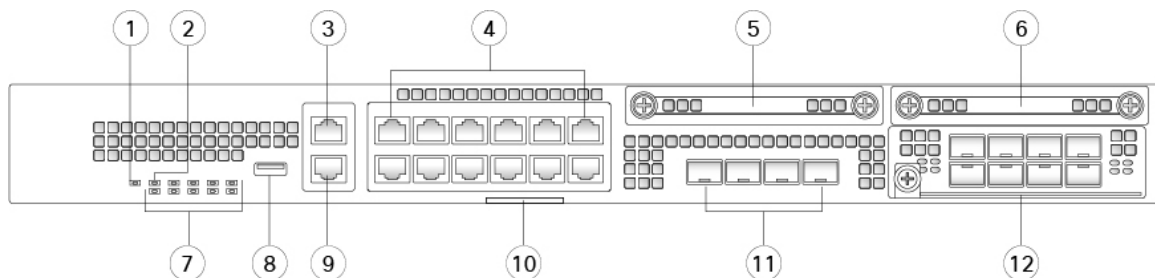

1	Power LED	2	Locator LED
3	Gigabit Ethernet management port: <ul style="list-style-type: none"> • Firepower Threat Defense—Management 0 (also referred to as Management 1/1 and Diagnostic 1/1) • ASA—Management 1/1 	4	12 RJ-45 1 G/100 M/10 M auto duplex/auto MDI-X Base-T ports Ethernet 1/1 through 1/12 labeled top to bottom, left to right
5	SSD 1	6	SSD 2
7	System LEDs	8	Type A USB 2.0 port
9	RJ-45 console port	10	Pullout asset card with chassis serial number
11	Four fixed SFP+ (1 Gb/10 Gb) ports Fiber ports 1/13 through 1/16 labeled left to right	12	Network module (network module slot 1)

Management Port

The Firepower 2100 chassis has an RJ-45 copper management port.

RJ-45 Console Port

The Firepower 2100 chassis has a standard RJ-45 console port. You can use the CLI to configure your 2100 through the RJ-45 serial console port by using a terminal server or a terminal emulation program on a computer.

The RJ-45 (8P8C) port supports RS-232 signaling to an internal UART controller. The console port does not have any hardware flow control, and does not support a remote dial-in modem. The baud rate is 9600. You can use the standard cable found in your accessory kit to convert the RJ-45 to DB-9 if necessary.

Type A USB Port

You can use the external Type A USB port to attach a data-storage device. The external USB drive identifier is `usbA:`. The Type A USB port supports the following:

- Hot swapping
- USB drive formatted with FAT32
- Boot kickstart image from ROMMON for discovery recovery purposes
- Copy files to and from `workspace:/` and `volatile:/` within local-mgmt. The most relevant files are:
 - Core files
 - Ethalyzer packet captures
 - Tech-support files
 - Security module log files
- Platform bundle image upload using **download image usbA:**

The Type A USB port does *not* support Cisco Secure Package (CSP) image upload support.

Network Ports

The Firepower 2100 chassis has 12 fixed RJ-45 1 G/100 M/10 M) ports. They are numbered from top to bottom, left to right starting with 1 and are named Ethernet 1/1 through Ethernet 1/12.

The Firepower 2110 and 2120 also have four fixed SFP (1 Gb) ports, and the Firepower 2130 and 2140 have four fixed SFP+ (1 Gb/10 Gb) ports. They are fiber ports numbered left to right (1/13 through 1/16).

Each port has LEDs that represent Link/Activity status.

Front Panel LEDs

The following figure shows the Firepower 2110 and 2120 front panel LEDs.

Figure 11: Firepower 2110 and 2120 Front Panel LEDs

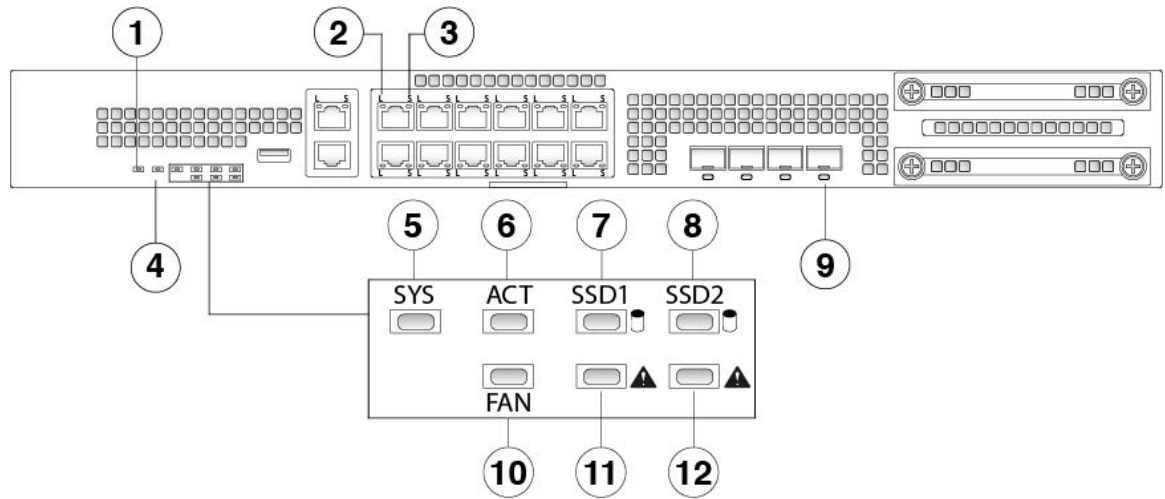

<p>1 PWR</p> <ul style="list-style-type: none"> • Off—Input power is not detected. Standby power is off. • Green, flashing—System has detected a power switch toggle event, and initiated the shutdown sequence. <p>Note If the power switch is in the OFF position, the system powers off after shutdown is completed. Do not remove the AC or DC power source while this LED is blinking so that the system has time to perform a graceful shutdown.</p> <ul style="list-style-type: none"> • Amber—System is powering up (before the BIOS boots). This takes one to five seconds at most. • Green—System is fully powered up. 	<p>2 Ethernet Link</p> <ul style="list-style-type: none"> • Green—The link partner is detected; no activity. • Green, flashing—Network activity is detected.
<p>3 Ethernet Speed</p> <ul style="list-style-type: none"> • Green, flashing—The number of flashes determines link speed; 1 flash=10 Mbit, 2=100 Mbit, 3=1 Gbit. 	<p>4 Locator</p> <ul style="list-style-type: none"> • Off—Locate is off. • Blue—Locate is on. <p>Note The Locator LED helps you locate a unit that needs physical service attention. This feature is activated in the software.</p>

<p>5 SYS (Health)</p> <ul style="list-style-type: none"> • Off—System has not booted up yet. • Green, flashing quickly—System is booting up. • Green—Normal system function. • Amber—System boot up has failed. • Amber, flashing—Alarm condition, system needs service or attention and may not boot properly. • Green, flashing slowly (twice in 5 seconds)—Cloud connected. <p>Note Cisco Defense Orchestrator (CDO) is valid for FTD 6.7 and later.</p> <ul style="list-style-type: none"> • Green and amber, flashing—Cloud connection failure. • Green—Cloud disconnected. <p>Note The CDO LED pattern applies to low touch provisioning (LTP). See the Firepower Easy Deployment Guide for Cisco Firepower 1000 or 2100 Firewalls for more information.</p>	<p>6 ACT (Role of a high-availability pair)</p> <ul style="list-style-type: none"> • Off—Unit is not configured or enabled in a high-availability pair. • Green—Unit is in active mode. • Amber—Unit is in standby mode.
<p>7 SSD1</p> <ul style="list-style-type: none"> • Off—SSD is not present. • Green—SSD is present; no activity. • Green, flashing—SSD is active. 	<p>8 SSD2</p> <ul style="list-style-type: none"> • Off—SSD is not present. • Green—SSD is present; no activity. • Green, flashing—SSD is active.

<p>9 Fiber Port</p> <ul style="list-style-type: none"> • Green—Port is enabled, the link partner is detected. • Amber—Port is enabled, but the link partner is not detected. • Green, flashing—Port is enabled; network activity is detected. 	<p>10 FAN</p> <ul style="list-style-type: none"> • Off—Environmental subsystem is not active yet. • Green—Fans are running normally. It may take up to one minute for the LED status to turn green after power is on. • Amber—One fan has failed. The system can continue to operate normally, but fan service is required. • Amber, flashing—Two or more fans have failed, or the fan tray has been removed from the system. Immediate attention is required.
<p>11 SSD1 Alert Status</p> <ul style="list-style-type: none"> • Off—SSD has normal activity. • Amber—SSD failure. 	<p>12 SSD2 Alert Status</p> <ul style="list-style-type: none"> • Off—SSD has normal activity. • Amber—SSD failure.

The following figure shows the Firepower 2130 and 2140 front panel LEDs.

Figure 12: Firepower 2130 and 2140 Front Panel LEDs

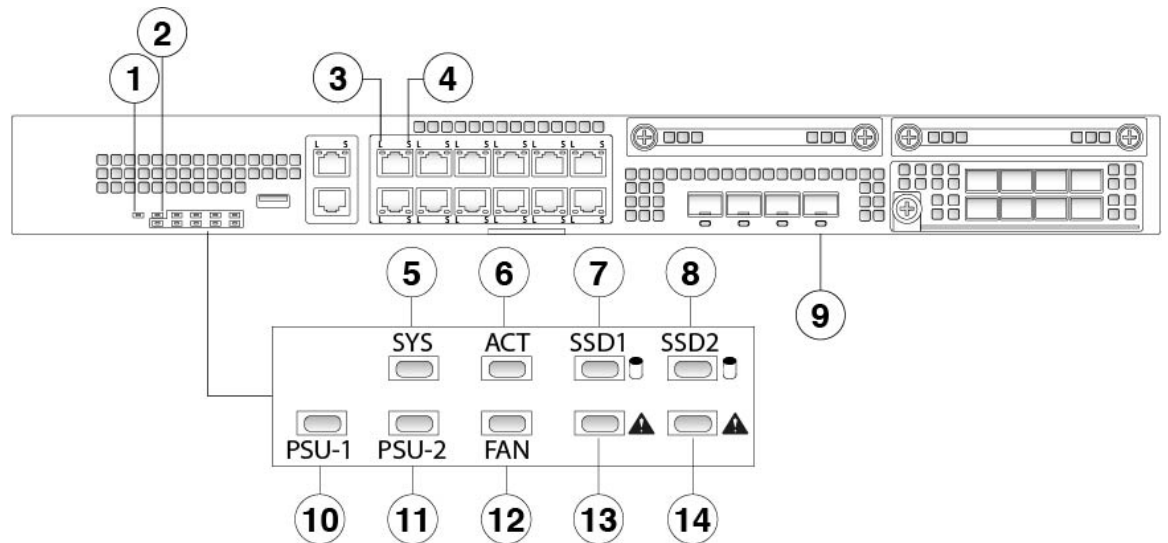

<p>1 Power</p> <ul style="list-style-type: none"> • Off—Input power is not detected. Standby power is off. • Green, flashing—The system has detected a power switch toggle event, and initiated the shutdown sequence. If the power switch is in the OFF position, the system powers off after shutdown is completed. Do not remove the AC or DC power source while this LED is blinking so that the system has time to perform a graceful shutdown. • Amber—The system is powering up (before the BIOS boots). This takes one to five seconds at most. • Green—The system is fully powered up. 	<p>2 Locator</p> <ul style="list-style-type: none"> • Off—Locate is off. • Blue—Locate is on. <p>Note The Locator LED helps you locate a unit that needs physical service attention. This feature is activated in the software.</p>
<p>3 Ethernet Link</p> <ul style="list-style-type: none"> • Green—The link partner is detected; no activity. • Green, flashing—Network activity is detected. 	<p>4 Ethernet Speed</p> <ul style="list-style-type: none"> • Green, flashing—The number of flashes determines link speed; 1 flash=10 Mbit, 2=100 Mbit, 3=1 Gbit.

<p>5 SYS (Health)</p> <ul style="list-style-type: none"> • Off—System has not booted up yet. • Green, flashing quickly—System is booting up. • Green—Normal system function. • Amber—System boot up has failed. • Amber, flashing—Alarm condition, system needs service or attention and may not boot properly. • Green, flashing slowly (twice in 5 seconds)—Cloud connected. <p>Note Cisco Defense Orchestrator (CDO) is valid for FTD 6.7 and later.</p> <ul style="list-style-type: none"> • Green and amber, flashing—Cloud connection failure. • Green—Cloud disconnected. <p>Note The CDO LED pattern applies to low touch provisioning (LTP). See the Firepower Easy Deployment Guide for Cisco Firepower 1000 or 2100 Firewalls for more information.</p>	<p>6 ACT (Role of a high-availability pair)</p> <ul style="list-style-type: none"> • Off—The unit is not configured or enabled in a high-availability pair. • Green—The unit is in active mode. • Amber—The unit is in standby mode.
<p>7 SSD1</p> <ul style="list-style-type: none"> • Off—The SSD is not present. • Green—The SSD is present; no activity. • Green, flashing—The SSD is active. 	<p>8 SSD2</p> <ul style="list-style-type: none"> • Off—The SSD is not present. • Green—The SSD is present; no activity. • Green, flashing—The SSD is active.
<p>9 Fiber Port</p> <ul style="list-style-type: none"> • Green—Port is enabled, the link partner is detected. • Amber—Port is enabled, but the link partner is not detected. • Green, flashing—Port is enabled; network activity is detected. 	<p>10 PSU-1</p> <ul style="list-style-type: none"> • Off—The power supply module is not present or not detected. • Green—The power supply module is present and working properly. • Amber—The power supply module is present but a fault or problem has been detected.

<p>11 PSU-2</p> <ul style="list-style-type: none"> • Off—The power supply module is not present or not detected. • Green—The power supply module is present and working properly. • Amber—The power supply module is present but a fault or problem has been detected. 	<p>12 FAN</p> <ul style="list-style-type: none"> • Off—The environmental subsystem is not active yet. • Green—The fans are running normally. It may take up to one minute for the LED status to turn green after power is on. • Amber—One fan has failed. The system can continue to operate normally, but fan service is required. • Amber, flashing—Two or more fans have failed, or the fan tray has been removed from the system. Immediate attention is required.
<p>13 SSD1 Alert Status</p> <ul style="list-style-type: none"> • Off—SSD has normal activity. • Amber—SSD failure. 	<p>14 SSD2 Alert Status</p> <ul style="list-style-type: none"> • Off—SSD has normal activity. • Amber—SSD failure.

Rear Panel

The following figure shows the rear panel of the Firepower 2110 and 2120.

Figure 13: Firepower 2110 and 2120 Rear Panel

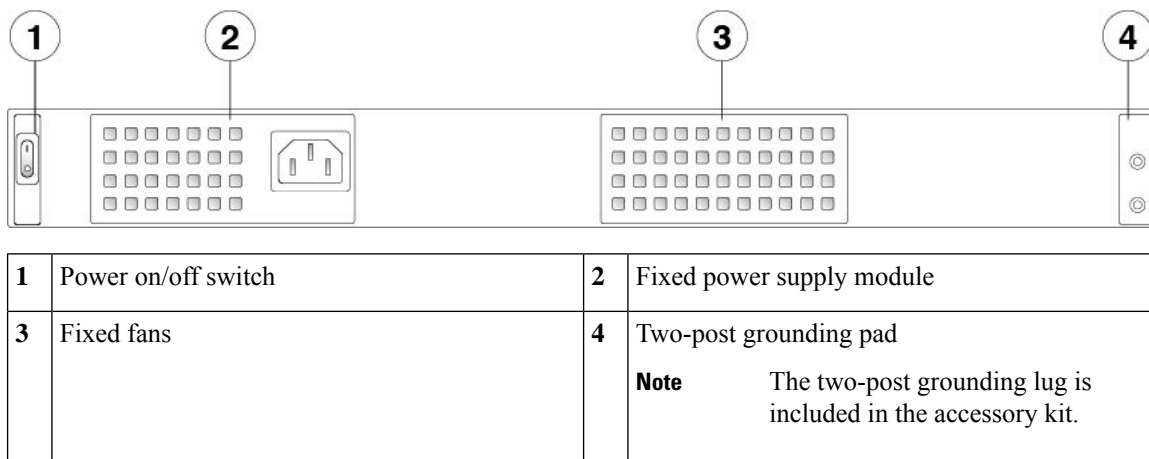

The following figure shows the rear panel of the Firepower 2130 and 2140.

Figure 14: Firepower 2130 and 2140 Rear Panel

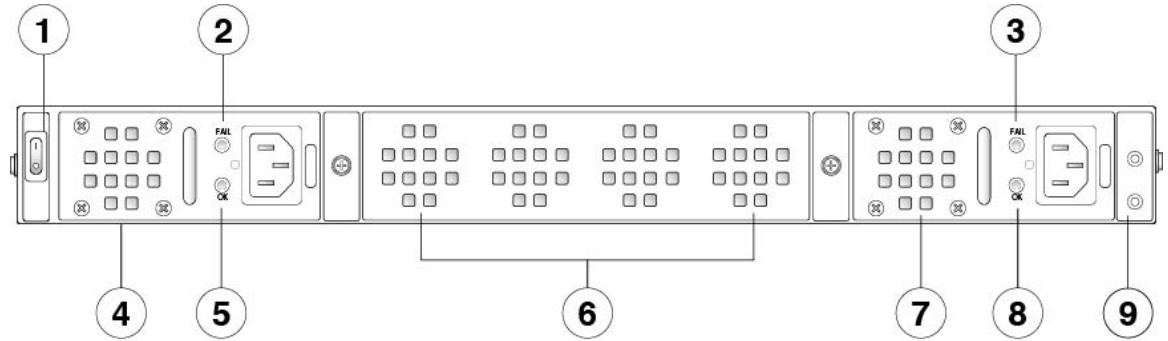

1	Power on/off switch	2	Power supply module 1 FAIL LED
3	Power supply module 2 FAIL LED	4	Power supply module 1
5	Power supply module 1 OK LED	6	Fan tray
7	Power supply module 2	8	Power supply module 2 OK LED
9	Two-post grounding pad		
	Note The two-post grounding lug is included in the accessory kit.		

Power Switch

The power switch is located to the left of power supply module 1 on the rear of the chassis. It is a toggle switch that controls power to the system. If the power switch is in standby position, only the 3.3-V standby power is enabled from the power supply module and the 12-V main power is OFF. When the switch is in the ON position, the 12-V main power is turned on and the system boots.

Before you move the power switch to the OFF position, use the **shutdown** commands so that the system can perform a graceful shutdown. This may take several minutes to complete. After the graceful shutdown is complete, the console displays `It is safe to power off now.` The front panel blue locator beacon LED lights up indicating the system is ready to be powered off. You can now move the switch to the OFF position. The front panel PWR LED flashes momentarily and turns off.

See [Front Panel LEDs, on page 12](#) for the PWR LED description. See the [FXOS Configuration Guide](#) for more information on using the **shutdown** commands.



Note On the Firepower 2130 and 2140, the OK LEDs on the rear power supplies flash after the switch is turned off; this is expected behavior.



Caution If you move the power switch to the OFF position before the **shutdown** command sequence is complete or if you remove the system power cords before the graceful shutdown is complete, disk corruption can occur.



Note After removing power from the chassis by unplugging the power cord, wait at least 10 seconds before turning power back ON.

For More Information

- See [Remove and Replace the Power Supply Module](#) for the procedure for removing and replacing the power supply module in the Firepower 2130 and 2140.
- See [Remove and Replace the Fan Tray](#) for the procedure for removing and replacing the fan tray in the Firepower 2130 and 2140.
- See [Ground the Chassis](#) for the procedure for using the grounding lug to ground the chassis.
- See [Power Supply Modules, on page 28](#) for a description of the power supply module LEDs.
- See [Front Panel LEDs, on page 12](#) for a description of the fan LEDs.

Network Modules

The Firepower 2130 and 2140 contain one network module slot that provides optical or electrical network interfaces. Network modules are optional, removable I/O modules that provide either additional ports or different interface types. The Firepower network module plugs into the chassis on the front panel.

For More Information

- See [10-Gb Network Module, on page 20](#) for a description of the 10-Gb network module.
- See [1-Gb Network Module, on page 22](#) for a description of the 1-Gb network module.
- See [Supported SFP/SFP+ Transceivers, on page 32](#) for a list of supported SFPs.
- See [Install, Remove, and Replace the Network Module](#) for the procedure for removing and replacing network modules.

10-Gb Network Module

The following figure shows the front panel of the 10-Gb network module (FPR2K-NM-8X10G). The FPR2K-NM-8X10G is a single-wide module that supports hot swapping. The eight ports are numbered from top to bottom, left to right.



Note Make sure you have the correct firmware package and software version installed to support this network module. See [Cisco FXOS Troubleshooting Guide for the Firepower 1000/2100 with Firepower Threat Defense](#) for the procedure to verify your firmware package and software version. See [Cisco Firepower 2100 ASA Platform Mode FXOS Configuration Guide](#) for the procedure to upgrade the firmware package for the Firepower 2100 running ASA with FXOS. See the [Cisco Firepower Compatibility Guide](#) and the [Cisco ASA Compatibility](#) guide, which provide Cisco software and hardware compatibility, including operating system and hosting environment requirements, for each supported version



Note The FPR2K-NM-8X10G is NEBS-compliant.



Note You can fit four copper SFPs in either the top row of ports or the bottom row of ports. Both rows cannot be populated at the same time, because of the port row spacing.

Figure 15: FPR2K-NM-8X10G

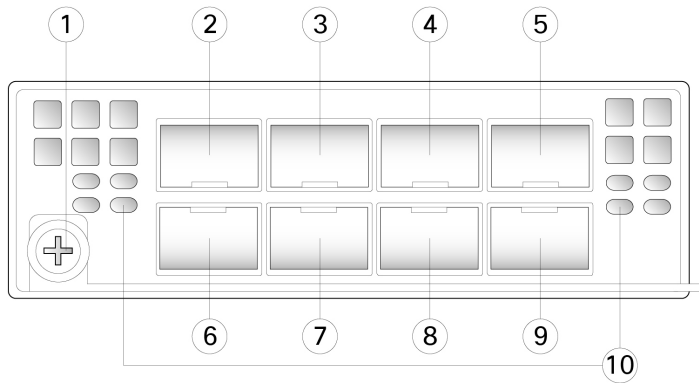

1	Captive screw/handle	2	Ethernet X/1
3	Ethernet X/3	4	Ethernet X/5
5	Ethernet X/7	6	Ethernet X/2
7	Ethernet X/4	8	Ethernet X/6
9	Ethernet X/8	10	Network activity LEDs <ul style="list-style-type: none"> • Off—No connection or port is not in use. • Amber—No link or network failure. • Green—Link up. • Green, flashing—Network activity.

For More Information

- For a list of copper SFPs, see [Supported SFP/SFP+ Transceivers, on page 32](#).

1-Gb Network Module

The following figure shows the front panel of the 1-Gb network module (FPR2K-NM-8X1G). The FPR2K-NM-8X1G is a single-wide module that supports hot swapping. The eight ports are numbered from top to bottom, left to right.



Note Make sure you have the correct firmware package and software version installed to support this network module. See [Cisco FXOS Troubleshooting Guide for the Firepower 1000/2100 with Firepower Threat Defense](#) for the procedure to verify your firmware package and software version. See [Cisco Firepower 2100 ASA Platform Mode FXOS Configuration Guide](#) for the procedure to upgrade the firmware package for the Firepower 2100 running ASA with FXOS. See the [Cisco Firepower Compatibility Guide](#) and the [Cisco ASA Compatibility guide](#), which provide Cisco software and hardware compatibility, including operating system and hosting environment requirements, for each supported version



Note The FPR2K-NM-8X1G is NEBS-compliant.



Note You can fit four copper SFPs in either the top row of ports or the bottom row of ports. Both rows cannot be populated at the same time, because of the port row spacing.

Figure 16: FPR2K-NM-8X1G

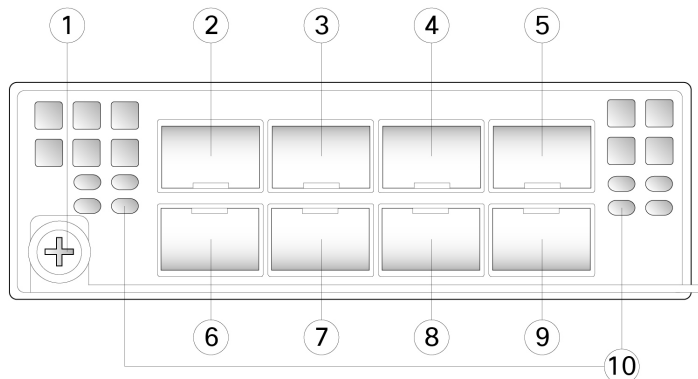

1	Captive screw/handle	2	Ethernet X/1
3	Ethernet X/3	4	Ethernet X/5
5	Ethernet X/7	6	Ethernet X/2
7	Ethernet X/4	8	Ethernet X/6

9	Ethernet X/8	10	Network activity LEDs <ul style="list-style-type: none"> • Off—No connection or port is not in use. • Amber—No link or network failure. • Green—Link up. • Green, flashing—Network activity.
---	--------------	----	--

For More Information

- For a list of copper SFPs, see [Supported SFP/SFP+ Transceivers, on page 32](#).

Hardware Bypass Network Modules

Hardware bypass (also known as fail-to-wire) is a physical layer (Layer 1) bypass that allows paired interfaces to go into bypass mode so that the hardware forwards packets between these port pairs without software intervention. Hardware bypass provides network connectivity when there are software or hardware failures. Hardware bypass is useful on ports where the Firepower security appliance is only monitoring or logging traffic. The hardware bypass network modules have an optical switch that is capable of connecting the two ports when needed. The hardware bypass network modules have built-in SFPs.

Hardware bypass is supported only on a fixed set of ports. You can pair Port 1 with Port 2, Port 3 with Port 4, but you cannot pair Port 1 with Port 4 for example.



Note When the appliance switches from normal operation to hardware bypass or from hardware bypass back to normal operation, traffic may be interrupted for several seconds. A number of factors can affect the length of the interruption; for example, behavior of the optical link partner such as how it handles link faults and debounce timing; spanning tree protocol convergence; dynamic routing protocol convergence; and so on. During this time, you may experience dropped connections.

There are three configuration options for hardware bypass network modules:

- **Passive interfaces**—Connection to a single port.
For each network segment you want to monitor passively, connect the cables to one interface. This is how the nonhardware bypass network modules operate.
- **Inline interfaces**—Connection to any two like ports (10 Gb to 10 Gb for example) on one network module, across network modules, or fixed ports.
For each network segment you want to monitor inline, connect the cables to pairs of interfaces.
- **Inline with hardware bypass interfaces**—Connection of a hardware bypass paired set.
For each network segment that you want to configure inline with fail-open, connect the cables to the paired interface set.
For the 40-Gb network module, you connect the two ports to form a paired set. For the 1/10-Gb network modules, you connect the top port to the bottom port to form a hardware bypass paired set. This allows traffic to flow even if the security appliance fails or loses power.



Note If you have an inline interface set with a mix of hardware bypass and nonhardware bypass interfaces, you cannot enable hardware bypass on this inline interface set. You can only enable hardware bypass on an inline interface set if all the pairs in the inline set are valid hardware bypass pairs.

For More Information

- See [1-Gb SX/10-Gb SR/10-Gb LR Network Module with Hardware Bypass](#) , on page 24 for a description of the 1-G SX, 10-G SR, and LR network modules.
- See [1-Gb Network Module with Hardware Bypass](#) , on page 27 for a description of the 1-G network module.
- See [Install, Remove, and Replace the Network Module](#) for the procedure for removing and replacing single-wide network modules.

1-Gb SX/10-Gb SR/10-Gb LR Network Module with Hardware Bypass

The following figure shows the front panel of the 1-Gb SX, 10-Gb SR and 10-Gb LR hardware bypass network modules FPR2K-NM-6X1SX-F, FPR2K-NM-6X10SR-F, FPR2K-NM-6X10LR-F). This is a single-wide module that does *not* support hot swapping. The six ports are numbered from top to bottom, left to right. Pair ports 1 and 2, 3 and 4, and 5 and 6 to form hardware bypass paired sets.



Note Make sure you have the correct firmware package and software version installed to support this network module. See [Cisco FXOS Troubleshooting Guide for the Firepower 1000/2100 with Firepower Threat Defense](#) for the procedure to verify your firmware package and software version. See [Cisco Firepower 2100 ASA Platform Mode FXOS Configuration Guide](#) for the procedure to upgrade the firmware package for the Firepower 2100 running ASA with FXOS. See the [Cisco Firepower Compatibility Guide](#) and the [Cisco ASA Compatibility guide](#), which provide Cisco software and hardware compatibility, including operating system and hosting environment requirements, for each supported version

Figure 17: FPR2K-NM-6X1SX-F, FPR2K-NM-6X10SR-F, FPR2K-NM-6X10LR-F

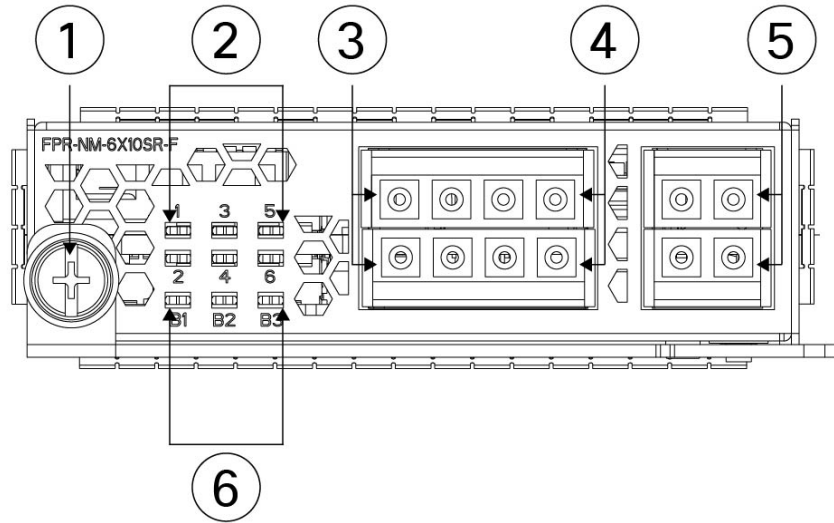

1	Captive screw/handle	2	Six network activity LEDs: <ul style="list-style-type: none"> • Amber—No connection, or port is not in use, or no link or network failure. • Green—Link up, no network activity. • Green, flashing—Network activity.
3	Ethernet X/1 (top port) Ethernet X/2 (bottom port) Ports 1 and 2 are paired together to form a hardware bypass pair.	4	Ethernet X/3 (top port) Ethernet X/4 (bottom port) Ports 3 and 4 are paired together to form a hardware bypass pair.
5	Ethernet X/5 (top port) Ethernet X/6 (bottom port) Ports 5 and 6 are paired together to form a hardware bypass pair.	6	Bypass LEDs B1 through B3: <ul style="list-style-type: none"> • Green—In standby mode. • Amber, flashing—Port is in hardware bypass mode, failure event.

The 1-Gb SX /10-Gb SR/10-Gb LR network modules have the following insertion loss measurements. Insertion loss measurements help you to troubleshoot the network by verifying cable installation and performance.

Table 2: 1-Gb SX Network Module (FPR2K-NM-6X1SX-F)

	Operating Mode	Typical	Maximum
Insertion loss	Normal	0.9 dB	1.4 dB
	Hardware bypass	1.2 dB	1.7 dB

	Core diameter (microns)	Modal bandwidth (MHz/km)	Cable distance Note Half the distance specified by the IEEE standard.
Cable and operating distance	62.5	160 (FDDI)	110 m
	62.5	200 (OM1)	137 m
	50	400	250 m
	50	500 (OM2)	275 m
	50	2000 (OM3)	500 m

Table 3: 10-Gb SR Network Module (FPR2K-NM-6X10SR-F)

	Operating Mode	Typical	Maximum
Insertion loss	Normal	0.9 dB	1.4 dB
	Hardware bypass	1.2 dB	1.7 dB
	Core diameter (microns)	Modal bandwidth (MHz/km)	Cable distance Note Half the distance specified by the IEEE standard.
Cable and operating distance	62.5	160 (FDDI)	13 m
	62.5	200 (OM1)	16.5 m
	50	400	33 m
	50	500 (OM2)	41 m
	50	2000 (OM3)	150 m
	50	4700 (OM4)	200 m

Table 4: 10-Gb LR Network Module (FPR2K-NM-6X10LR-F)

	Operating Mode	Typical	Maximum
Insertion loss	Normal	1.2 dB	1.6 dB
	Hardware bypass	1.5 dB	1.9 dB

	Core diameter (microns)	Modal bandwidth (MHz/km)	Cable distance Note Half the distance specified by the IEEE standard.
Cable and operating distance	G.652	Single mode	5 km

1-Gb Network Module with Hardware Bypass

The following figure shows the front panel view of the 1-Gb network module with hardware bypass (FPR-NM-8X1G-F). Pair ports 1 and 2, 3 and 4, 5 and 6, and 7 and 8 to form hardware bypass paired sets.



Note Make sure you have the correct firmware package and software version installed to support this network module. See [Cisco FXOS Troubleshooting Guide for the Firepower 1000/2100 with Firepower Threat Defense](#) for the procedure to verify your firmware package and software version. See [Cisco Firepower 2100 ASA Platform Mode FXOS Configuration Guide](#) for the procedure to upgrade the firmware package for the Firepower 2100 running ASA with FXOS.

Figure 18: FPR-NM-8X1G-F

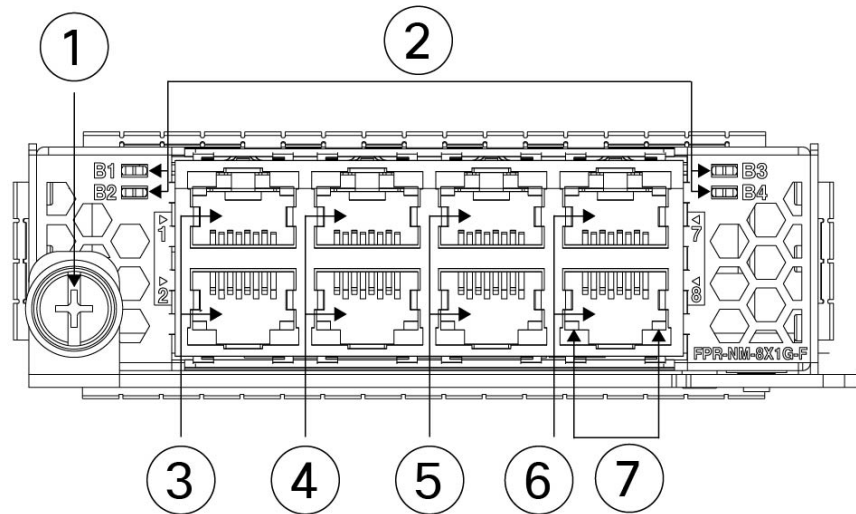

1	Captive screw/handle	2	Bypass LEDs B1 through B4 <ul style="list-style-type: none"> • Green—In standby mode. • Amber, flashing—Port is in hardware bypass mode, failure event.
----------	----------------------	----------	---

3 Ethernet X/1 Ports 1 and 2 are paired together to form a hardware bypass pair. LED B1 applies to this paired port.	4 Ethernet X/2 Ports 3 and 4 are paired together to form a hardware bypass pair. LED B2 applies to this paired port.
5 Ethernet X/2 Ports 5 and 6 are paired together to form a hardware bypass pair. LED B3 applies to this paired port.	6 Ethernet X/2 Ports 7 and 8 are paired together to form a hardware bypass pair. LED B4 applies to this paired port.
7 Network activity LEDs <ul style="list-style-type: none"> • Left LED—Green indicates network activity when a 10M/100M/1G connection is made. • Right LED—Not in use at this time. 	—

Power Supply Modules

The Firepower 2110 and 2120 have one fixed AC power supply that is not field-replaceable. If the power supply fails, you must get a return material authorization (RMA) for the entire chassis. See the [Cisco Returns Portal](#) for more information.

The Firepower 2130 and 2140 support two AC power supply modules so that dual power supply redundancy protection is available. The Firepower 2130 ships with one AC power supply and the Firepower 2140 ships with two AC power supplies. You can also install DC power supply modules instead of AC power on the 2130 and 2140. Facing the back of the chassis, the power supply modules are numbered left to right, for example, PSU1 and PSU2.

The power supply module is hot-swappable.

See [Product ID Numbers, on page 35](#) for a list of the PIDs associated with the Firepower 2100 series power supply modules.



Note You *cannot* mix AC and DC power supply modules in the chassis.



Note After removing power from the chassis by unplugging the power cord, wait at least 10 seconds before turning power back ON.



Attention Make sure that one power supply module is always active.



Note The system power requirements are lower than the power supply module capabilities. See the following table.

AC Power Supply

The dual power supplies can supply up to 800-W power across the input voltage range. The load is shared when both power supply modules are plugged in and running at the same time.



Note The system does not consume more than the capacity of one power supply module, so it will always operate in full redundancy mode (Firepower 2130 and 2140 only) when two power supply modules are installed.

Table 5: AC Power Supply Module Hardware Specifications

	2110	2120	2130	2140
Input voltage	100 to 240 V AC			
Maximum input current	< 4 A		< 6 A	
Maximum output power	250 W		400 W	
Frequency	50 to 60 Hz			
Efficiency	85% at 50% load		89% at 50% load	
Maximum redundancy output power	—		800W	
Redundancy	—		1+1 redundancy with dual power supply modules	

DC Power Supply

The power supplies can supply up to 350 W power across the input voltage range. The load is shared when both power supply modules are plugged in and running at the same time.

Table 6: DC Power Supply Module Hardware Specifications

	2130	2140
Input voltage	-48 to -60 V DC	
Maximum input current	< 15 A at -48 V	
	<p>Note The power supply module is rated at 15 A but the system power is limited to 6.1 A. See Hardware Specifications, on page 34 for more system specifications.</p>	

	2130	2140
Maximum output power	350 W	
Redundancy	1+1 redundancy with dual power supply modules	
Efficiency	> 88% at 50% load	

Power Supply Module LEDs

The following figure shows the bicolor power supply LEDs on the power supply module. The figure shows the AC power supply module. The DC power supply module has the same LEDs.

Figure 19: Power Supply Module LEDs

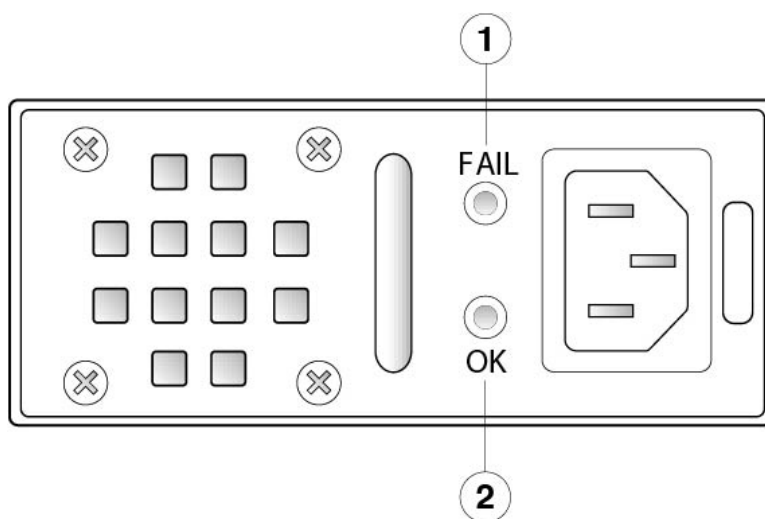

1	Amber FAIL LED	2	Green OK LED
----------	----------------	----------	--------------

The following describes the power module supply LEDs.

Green LED (OK Status)

- Off—Input power not present.
- Green, flashing—Input power present, but system is not powered up (power switch is off).
- Green—The power supply module is enabled and running.

Amber LED (Fail Status)

- Off—No fault detected.
- Amber, flashing—Fault warning, power supply may still work but could fail due to high temperature, failing fan, or over current.
- Amber—Fault detected; power supply not working properly. Includes over voltage, over current, over temperature, and fan failure.

For More Information

- See [Remove and Replace the Power Supply Module](#) for the procedure for removing and replacing the power supply module in the Firepower 2130 and 2140.

Fan Modules

The Firepower 2110 and 2120 have two fixed fans. If the fans fail, you must send your Firepower 2110 or 2120 for RMA.

The Firepower 2130 and 2140 have a removable fan tray with 3 + 1 redundant fans that are hot-swappable. The fan tray is installed in the rear of the chassis. Any one fan can fail indefinitely and the system continues to function. When a fan fails, the remaining fans automatically spin up to full speed.

The fan LED is located on the front of the chassis. See [Product ID Numbers, on page 35](#) for a list of the PIDs associated with the 2100 series fans.

For More Information

- See [Front Panel LEDs, on page 12](#) for the location and description of the fan LED.
- See [Remove and Replace the Fan Tray](#) for the procedure for removing and replacing the fan tray.

SSDs

The Firepower 2110 and 2120 have two SSD slots. These models ship with one 100-GB SSD installed in slot 1. The Firepower 2130 and 2140 have two SSD slots. These models ship with one 200-GB SSD installed in slot 1. See [Product ID Numbers, on page 35](#) for a list of the PIDs associated with the Firepower 2100 series SSDs. The SSD drive identifiers are `disk1` and `disk2`.

You can use the second SSD slot to upgrade to the MSP. The MSP *must* be installed in the second slot. The second SSD slot remains empty unless you install the MSP in the second slot. The MSP stores threat detection results for use in future analysis. It supports the Advanced Malware Protection (AMP) software feature. It is used as both storage and as the Malware application repository. RAID is not supported.



Caution You cannot swap SSDs between different Firepower platforms. For example, you cannot use a 4100 series SSD in a 2100 series chassis.



Note The 100-GB SSD is restricted to the Firepower 2110 and 2120 models. The 200-GB SSD is restricted to the Firepower 2130 and 2140 models. Do not mix them.

Although the hardware supports hot swapping for the SSDs, the software does not, so you must power down the chassis before removing and replacing them.

For More Information

- See [Front Panel LEDs, on page 12](#) for the location and description of the SSD LEDs on the front panel.
- See [Remove and Replace the SSD](#) for the procedure for removing and replacing the SSD.

Supported SFP/SFP+ Transceivers

The SFP/SFP+ transceiver is a bidirectional device with a transmitter and receiver in the same physical package. It is a hot-swappable optical or electrical (copper) interface that plugs into the SFP/SFP+ ports on the fixed ports and the network module ports, and provides Ethernet connectivity.

Figure 20: SFP Transceiver

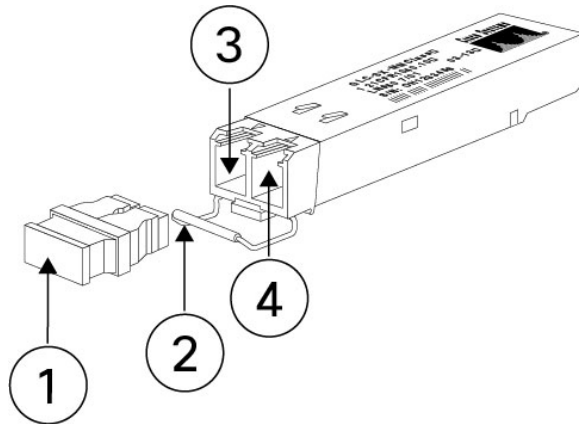

1	Dust plug	2	Bail clasp
3	Receive optical bore	4	Transmit optical bore

Safety Warnings

Take note of the following optical connection warnings:



Warning Statement 1051—Laser Radiation

Invisible laser radiation may be emitted from disconnected fibers or connectors. Do not stare into beams or view directly with optical instruments.



Warning Statement 1055—Class 1/1M Laser

Invisible laser radiation is present. Do not expose to users of telescopic optics. This applies to Class 1/1M laser products.





Warning Use appropriate ESD procedures when inserting the transceiver. Avoid touching the contacts at the rear, and keep the contacts and ports free of dust and dirt. Keep unused transceivers in the ESD packing that they were shipped in.



Note By default autonegotiation is enabled for 1-Gb fiber interfaces. In version 6.7 and later the ability to disable autonegotiation on 1-Gb fiber interfaces was added. This does not mean the interfaces can negotiate speed or support 10-M/100-M speeds. It means only that you can disable negotiation for a 1-Gb fiber interface. For example, you might disable negotiation if you are connecting to a tap type interface that cannot negotiate itself, because it might only receive and not transmit.



Caution Although non-Cisco SFPs are allowed, we do not recommend using them because they have not been tested and validated by Cisco. Cisco TAC may refuse support for any interoperability problems that result from using an untested third-party SFP transceiver.

The following table lists the supported transceivers.

Table 7: Supported SFPs

Optics Type	PID	Ports Supported
SFP 1Gb		
1G-SX	GLC-SX-MMD	Supported on Firepower 2110, 2120, 2130, and 2140 fixed ports (13 through 16). Supported on Firepower 2130 and 2140 ports 1 through 8 of the 8X1G network module.
1G-LH	GLC-LH-SMD	
1G-EX	GLC-EX-SMD	
1G-ZX	GLC-ZX-SMD	
1G 1000Base-T	GLC-T	Supported on all Firepower 2100 models.
1G 1000Base-T	GLC-TE	Supported on all Firepower 2100 models.
SFP+ 10Gb		

10G-SR	SFP-10G-SR	Supported on Firepower 2130 and 2140.
10G-LR	SFP-10G-LR	
10G-LRM	SFP-10G-LRM	
10G-ER	SFP-10G-ER	
10G-SR-S	SFP-10G-SR-S	
10G-LR-S	SFP-10G-LR-S	
10G-ZR-S	SFP-10G-ZR-S	
10G-ER-S	SFP-10G-ER-S	
H10GB-CU 1M, 1.5M, 2M, 2.5M, 3M, 5M	SFP-H10GB-CU1M SFP-H10GB-CU1-5M SFP-H10GB-CU2M SFP-H10GB-CU2-5 SFP-H10GB-CU3M SFP-H10GB-CU5M	
H10GB-ACU 7M, 10M	SFP-H10GB-ACU7M SFP-H10GB-ACU10M	
10G-AOC 1M, 2M, 3M, 5M, 7M, 10M	SFP-10G-AOC1M SFP-10G-AOC2M SFP-10G-AOC3M SFP-10G-AOC5M SFP-10G-AOC7M SFP-10G-AOC10M	

Hardware Specifications

The following table contains hardware specifications for the Firepower 2100 series.

Specification	2110	2120	2130	2140
Chassis dimensions (H x W x D)	1.73 x 16.90 x 19.76 inches (4.4 x 42.9 x 50.2 cm)			
Network module dimensions	1.2 x 3.7 x 9.6 inches (4.39 x 9.4 x 24.38)			
Weight	16.1 lb (7.3 kg)		19.4 lb (8.79 kg)	21 lb (9.52 kg)

Specification	2110	2120	2130	2140
System power	100/240V AC 1.9 A (at 100 VAC), 50 to 60 Hz Note The power supply module is rated at 4 A, but the system power is limited to 1.9 A.		100/240 V AC 2.9 A (at 100 VAC), 50 to 60 Hz Note The power supply module is rated at 6.3 A, but the system power is limited to 2.9 A.	
Temperature	Operating: 32 to 104°F (0 to 40°C) Nonoperating: -40 to 149°F (-40 to 65°C) maximum altitude is 40,000 ft			
NEBS	Operating altitude: 0 to 13,000 ft (3962 m) Operating temperature: <ul style="list-style-type: none"> • Long Term: 0 to 45°C up to 6000 ft (1829 m) • Long Term: 0 to 35°C 6000-13000 ft (1829-3964 m) • Short Term: -5 to 55°C up to 6000 ft (1829 m) Note Firepower 2100 series NEBS compliance applies only to the 2130.			
Humidity	Operating: 10 to 85 % noncondensing Nonoperating: 5 to 95 % noncondensing			
Altitude	Operating: 10,000 ft maximum Nonoperating: 40,000 ft maximum			
Sound pressure	47.3 dBA (typical) 73.4 dBA (maximum)		55.7 dBA (typical) 76.7 dBA (maximum)	
Sound power	60.2 (typical) 85.1 (maximum)		66 (typical) 84.5 (maximum)	

Product ID Numbers

The following table lists the PIDs associated with the Firepower 2100 series. All of the PIDs in the table are field-replaceable. If you need to get a return material authorization (RMA) for any component, see [Cisco Returns Portal](#) for more information.



Note See the **show inventory** and **show inventory expand** commands in the [Cisco FXOS Troubleshooting Guide for the Firepower 2100 Series](#) to display a list of the PIDs for your Firepower 2100. Or see the **show inventory** command in the [Cisco Firepower Threat Defense Command Reference](#) or the [Cisco ASA Series Command Reference](#) to display a list of the PIDs for your Firepower 2100.

Table 8: Firepower 2100 Series PIDs

PID	Description
FPR2110-NGFW-K9	Cisco Firepower 2110 NGFW appliance 1 RU
FPR2120-NGFW-K9	Cisco Firepower 2120 NGFW appliance 1 RU
FPR2130-NGFW-K9	Cisco Firepower 2130 NGFW appliance 1 RU with one network module bay
FPR2140-NGFW-K9	Cisco Firepower 2140 NGFW appliance 1 RU with one network module bay
FPR2110-ASA-K9	Cisco Firepower 2110 ASA appliance 1 RU
FPR2120-ASA-K9	Cisco Firepower 2120 ASA appliance 1 RU
FPR2130-ASA-K9	Cisco Firepower 2130 ASA appliance 1 RU with one network module bay
FPR2140-ASA-K9	Cisco Firepower 2140 ASA appliance 1 RU with one network module bay
FPR2110-K9=	Firepower 2110 appliance 1 RU with no power supply or fan (spare)
FPR2120-K9=	Firepower 2120 appliance 1 RU with no power supply or fan (spare)
FPR2130-K9=	Firepower 2130 appliance with one network module bay and no power supply or fan (spare)
FPR2140-K9=	Firepower 2140 appliance with one network module bay and no power supply or fan (spare)
FPR2K-PWR-DC-350	350 W DC power supply
FPR2K-PWR-DC-350=	350 W DC power supply (spare)
FPR2K-PWR-AC-400	400 W AC power supply
FPR2K-PWR-AC-400=	400 W AC power supply (spare)
FPR2K-PSU-BLANK	Power supply blank slot cover
FPR2K-PSU-BLANK=	Power supply blank slot cover (spare)
FPR2K-SSD100	SSD for Firepower 2110 and 2120
FPR2K-SSD100=	SSD for Firepower 2110 and 2120 (spare)
FPR2K-SSD200	SSD for Firepower 2130 and 2140
FPR2K-SSD200=	SSD for Firepower 2130 and 2140 (spare)

PID	Description
FPR2K-SSD-BBLKD	SSD slot carrier
FPR2K-SSD-BBLKD=	SSD slot carrier (spare)
FPR-MSP-SSD	MSP SSD
FPR-MSP-SSD=	MSP SSD (spare)
FPR2K-FAN	Fan tray for the Firepower 2130 and 2140
FPR2K-FAN=	Fan tray for the Firepower 2130 and 2140 (spare)
FPR2K-NM-8X1G	8-port 1-Gb SFP network module
FPR2K-NM-8X1G=	8-port 1-Gb SFP network module (spare)
FPR2K-NM-8X10G	8-port 10-Gb SFP+ network module
FPR2K-NM-8X10G=	8-port 10-Gb SFP+ network module (spare)
FPR2K-NM-6X1SX-F	6-port 1-Gb SX fiber hardware bypass network module
FPR2K-NM-6X1SX-F=	6-port 1-Gb SX fiber hardware bypass network module (spare)
FPR2K-NM-6X10LR-F	6-port 10-Gb LR hardware bypass network module
FPR2K-NM-6X10LR-F=	6-port 10-Gb LR hardware bypass network module (spare)
FPR2K-NM-6X10SR-F	6-port 10-Gb SR hardware bypass network module
FPR2K-NM-6X10SR-F=	6-port 10-Gb SR hardware bypass network module (spare)
FPR4K-NM-8X1G-F	8-port 1-Gb copper hardware bypass network module
FPR4K-NM-8X1G-F=	8-port 1-Gb copper hardware bypass network module (spare)
FPR2K-NM-BLANK	Network module blank slot cover
FPR2K-NM-BLANK=	Network module blank slot cover (spare)
FPR2K-CBL-MGMT	Cable management brackets
FPR2K-CBL-MGMT=	Cable management brackets (spare)
FPR2K-RM-BRKT=	Rack-mount brackets (spare)
FPR2K-SLIDE-RAILS	Slide rail kit
FPR2K-SLIDE-RAILS=	Slide rail kit (spare)

PID	Description
FPR2K-RAIL-BRKT=	Slide rail brackets (spare)

Power Cord Specifications

Each power supply has a separate power cord. Standard power cords or jumper power cords are available for connection to the security appliance. The jumper power cords for use in racks are available as an optional alternative to the standard power cords.

If you do not order the optional power cord with the system, you are responsible for selecting the appropriate power cord for the product. Using an incompatible power cord with this product may result in electrical safety hazard. Orders delivered to Argentina, Brazil, and Japan must have the appropriate power cord ordered with the system.



Note Only the approved power cords or jumper power cords provided with the security appliance are supported.

The following power cords are supported.

Figure 21: Argentina CAB-ACR

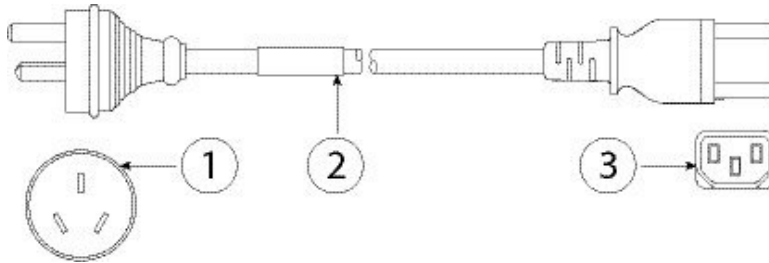

1	Plug: IRAM 2073	2	Cord set rating: 10 A, 250 V
3	Connector: IEC 60320/C13		

Figure 22: Australia CAB-ACA

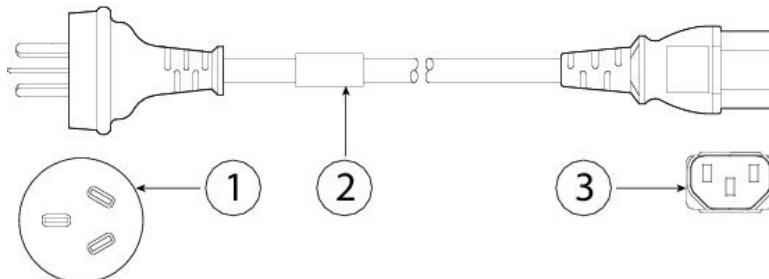

1	Plug: A.S. 3112	2	Cord set rating: 10 A, 250 V
3	Connector: IEC 60320/C13		

Figure 23: Brazil CAB-C13-ACB

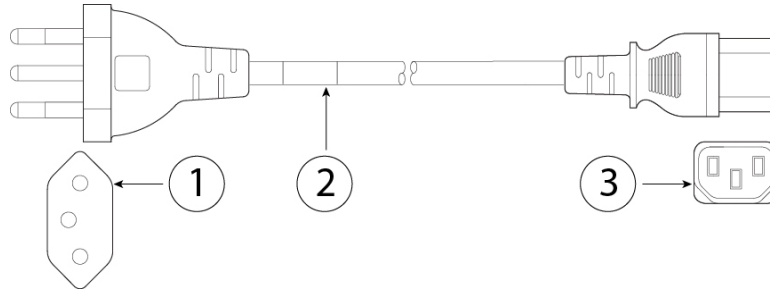

1	Plug: NBR 14136	2	Cord set rating: 10 A, 250 V
3	Connector: IEC 60320/C13		

Figure 24: China CAB-ACC

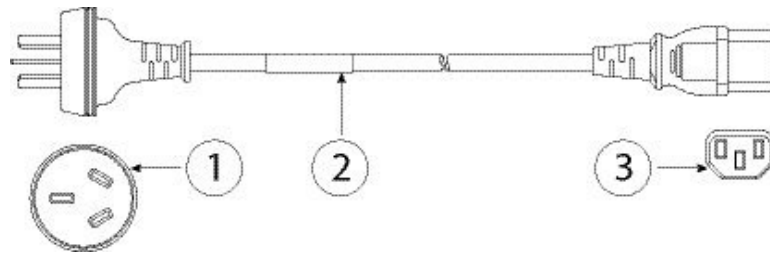

1	Plug: GB2099.1-2008/GB1002	2	Cord set rating: 10 A, 250 V
3	Connector: IEC 60320/C13		

Figure 25: Europe CAB-ACE

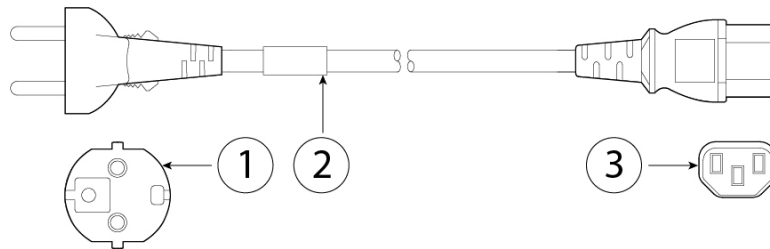

1	Plug: CEE 7 VII	2	Cord set rating: 10 A, 250 V
3	Connector: IEC 60320/C13		

Figure 26: India PWR-CORD-IND-D

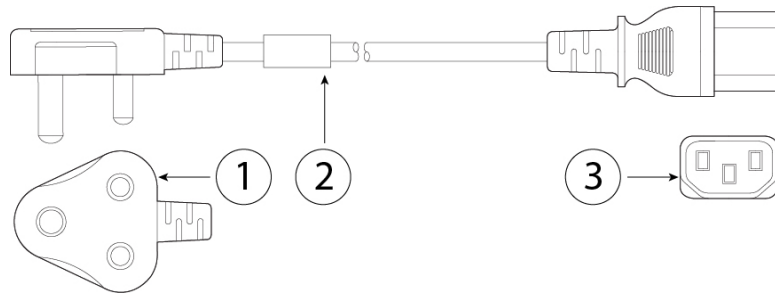

1	Plug: IS 6538-1971	2	Cord set rating: 10 A, 250 V
3	Connector: IEC 60320/C13		

Figure 27: Italy CAB-ACI

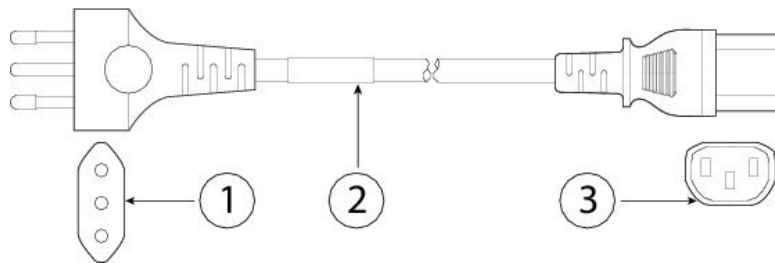

1	Plug: CEI 23-16	2	Cord set rating: 10 A, 250 V
3	Connector: IEC 60320/C13		

Figure 28: Japan CAB-JPN

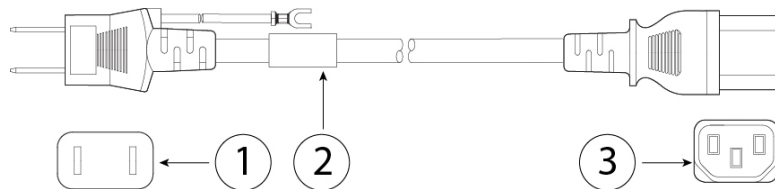

1	Plug: JIS C8303	2	Cord set rating: 12 A, 125 V
3	Connector: IEC 60320/C13		

Figure 29: Japan CAB-JPN-3PIN

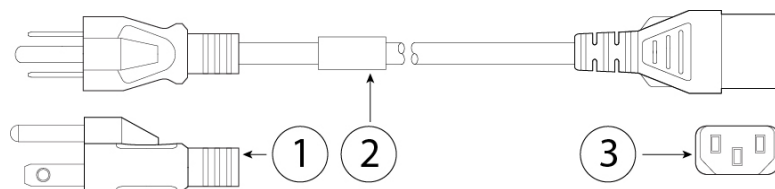

1	Plug: JIS C8303/JIS C8306	2	Cord set rating: 12 A, 125 V
3	Connector: IEC 60320/C13		

Figure 30: Jumper CAB-C13-C14-2M

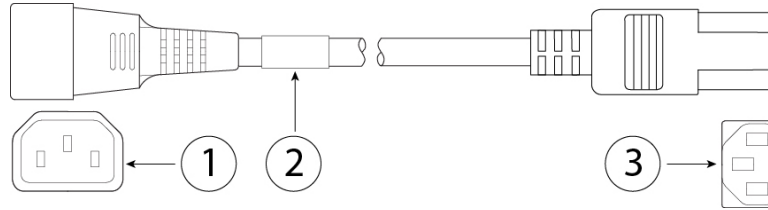

1	IEC 60320/C14G	2	Cord set rating: 10 A, 250 V
3	Connector: IEC 60320/C13		

Figure 31: Korea CAB-AC-C13-KOR

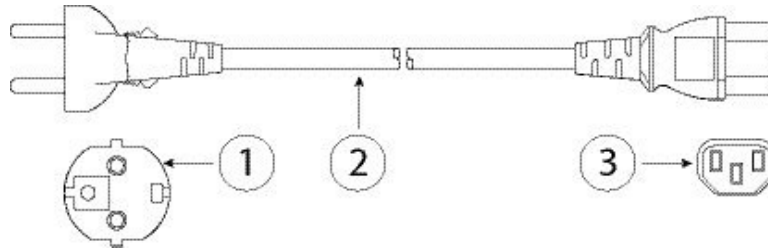

1	Plug: KSC 8305	2	Cord set rating: 10 A, 250 V
3	Connector: IEC 60320/C13		

Figure 32: North America CAB-AC

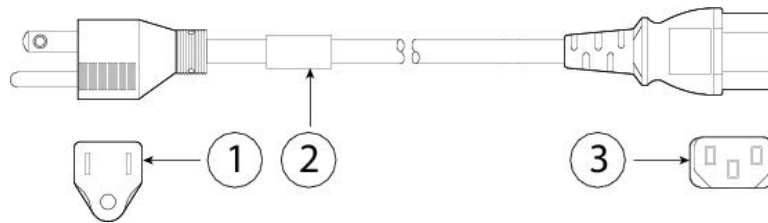

1	Plug: NEMA5-15P	2	Cord set rating: 10 A, 125 V
3	Connector: IEC 60320/C13		

Figure 33: South Africa CAB-ACSA

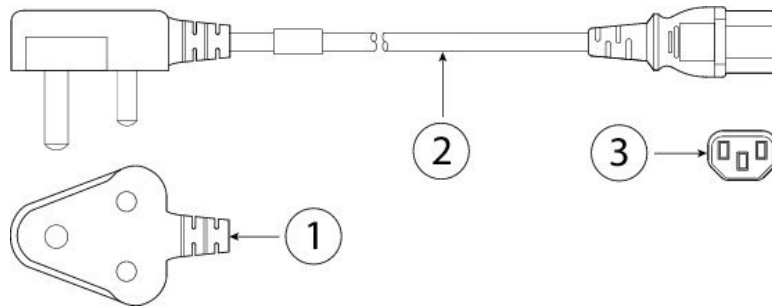

1	Plug: SABS 164	2	Cord set rating: 16 A, 250 V
3	Connector: IEC 60320/C13		

Figure 34: Switzerland CAB-ACS

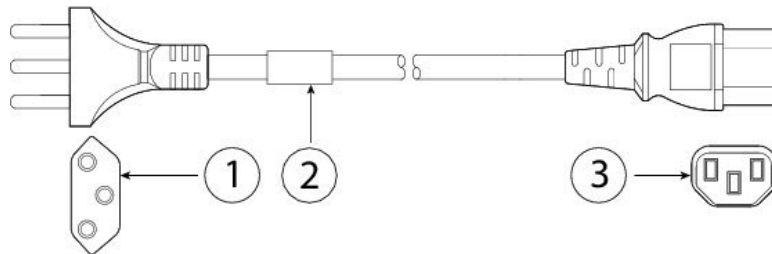

1	Plug: SEV 1011	2	Cord set rating: 10 A, 250 V
3	Connector: IEC 60320/C13		

Figure 35: Taiwan CAB-ACTW

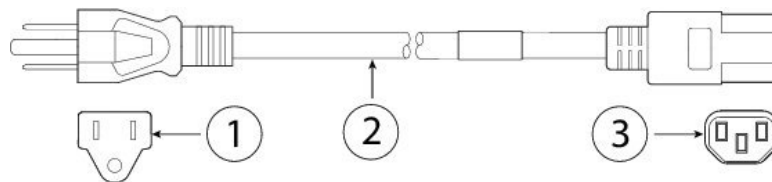

1	Plug: CNS10917	2	Cord set rating: 10 A, 125 V
3	Connector: IEC 60320/C13		

Figure 36: United Kingdom CAB-ACU

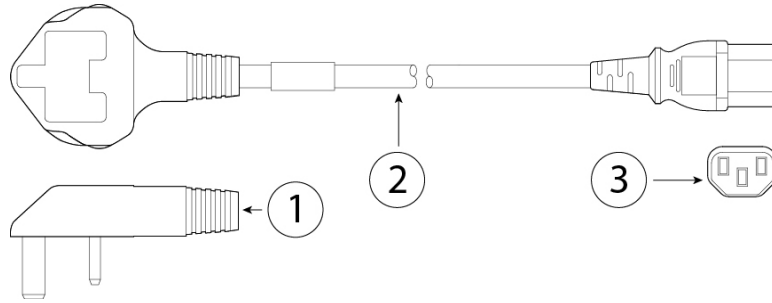

1	Plug: BS1363A/SS145	2	Cord set rating: 10 A, 250 V
3	Connector: IEC 60320/C13		

